

[54] THREE-WHEELED MOTOR VEHICLE

[76] Inventor: **Stuart Pivar**, 15 W. 67th St., New York, N.Y. 10023

[**] Term: **14 Years**

[21] Appl. No.: **897,959**

[22] Filed: **Apr. 20, 1978**

[51] Int. Cl. **D12-11; D12-08**

[52] U.S. Cl. **D12/85; D12/112**

[58] Field of Search **D12/110, 112, 85, 156; 180/25 R, 26 R, 27; 280/202, 281 B, 222, 231; 135/7; 296/78.1**

[56] **References Cited**

U.S. PATENT DOCUMENTS

- D. 234,757 4/1975 **Veziario** D12/112
- D. 245,903 9/1977 **Harris, Jr.** D12/156
- 3,888,324 6/1975 **Kossow** 180/26 R

FOREIGN PATENT DOCUMENTS

13707 of 1894 **United Kingdom** 135/7

OTHER PUBLICATIONS

Mobile-Modular Housing Dealer, 10/74, P116, Duo Cycle, bottom left side of page.

American Bicyclist & Motorcyclist, 1/75, P122, Surrey Selene, top of page.

Primary Examiner—James M. Gandy

Attorney, Agent, or Firm—Alan K. Roberts

[57] **CLAIM**

The ornamental design for a three-wheeled motor vehicle, substantially as shown and described.

DESCRIPTION

FIG. 1 is a top plan view of a three-wheeled motor vehicle showing my new design;

FIG. 2 is a side elevational view thereof;

FIG. 3 is a side elevational view thereof opposite to that shown in FIG. 2;

FIG. 4 is a front elevational view thereof;

FIG. 5 is a rear elevational view thereof;

FIG. 6 is a bottom plan view thereof; and

FIG. 7 is a perspective view of a three wheeled motor vehicle showing a second embodiment of my new design the sole difference being in the addition of a windshield and canopy unit.

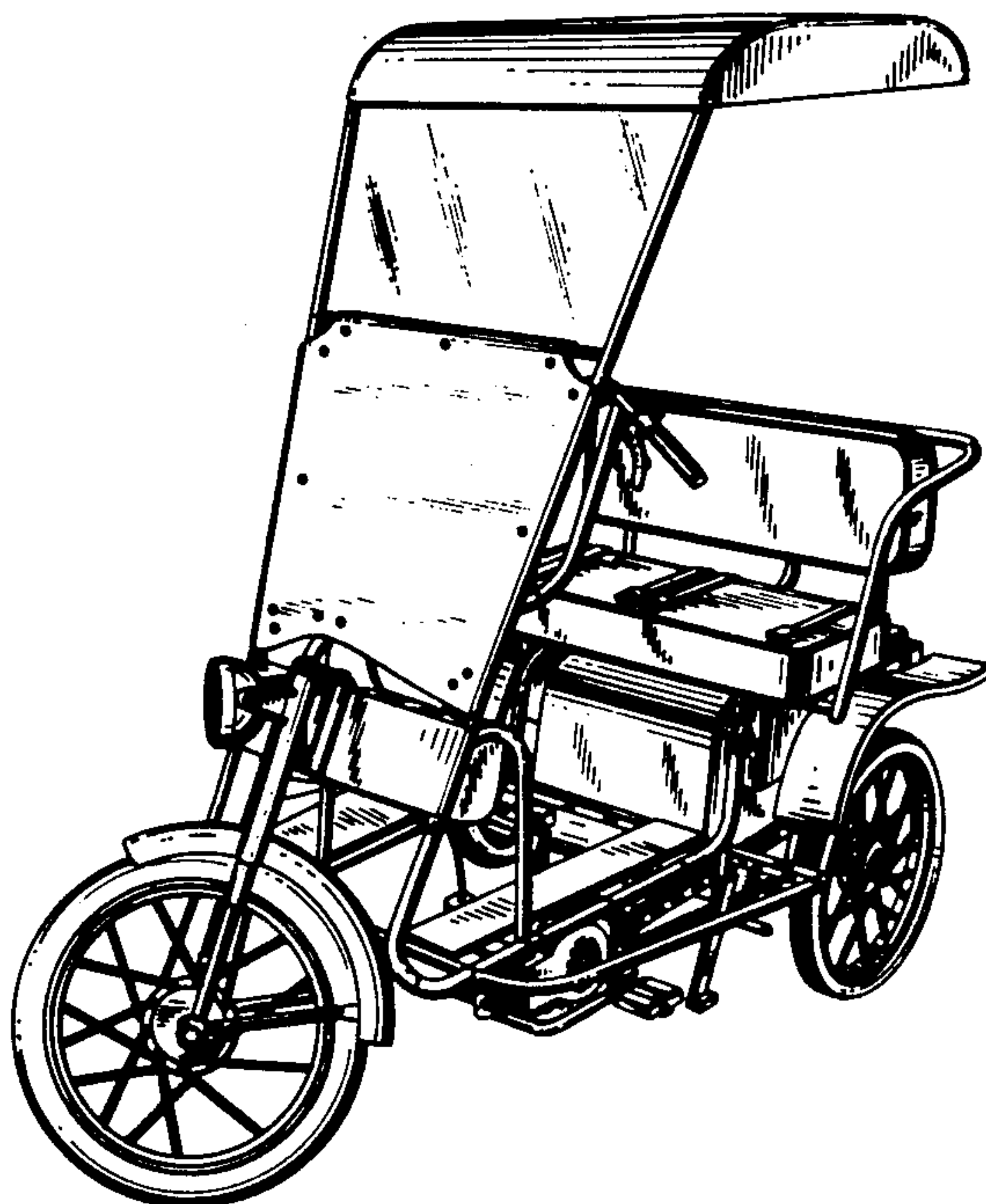

FIG. 1

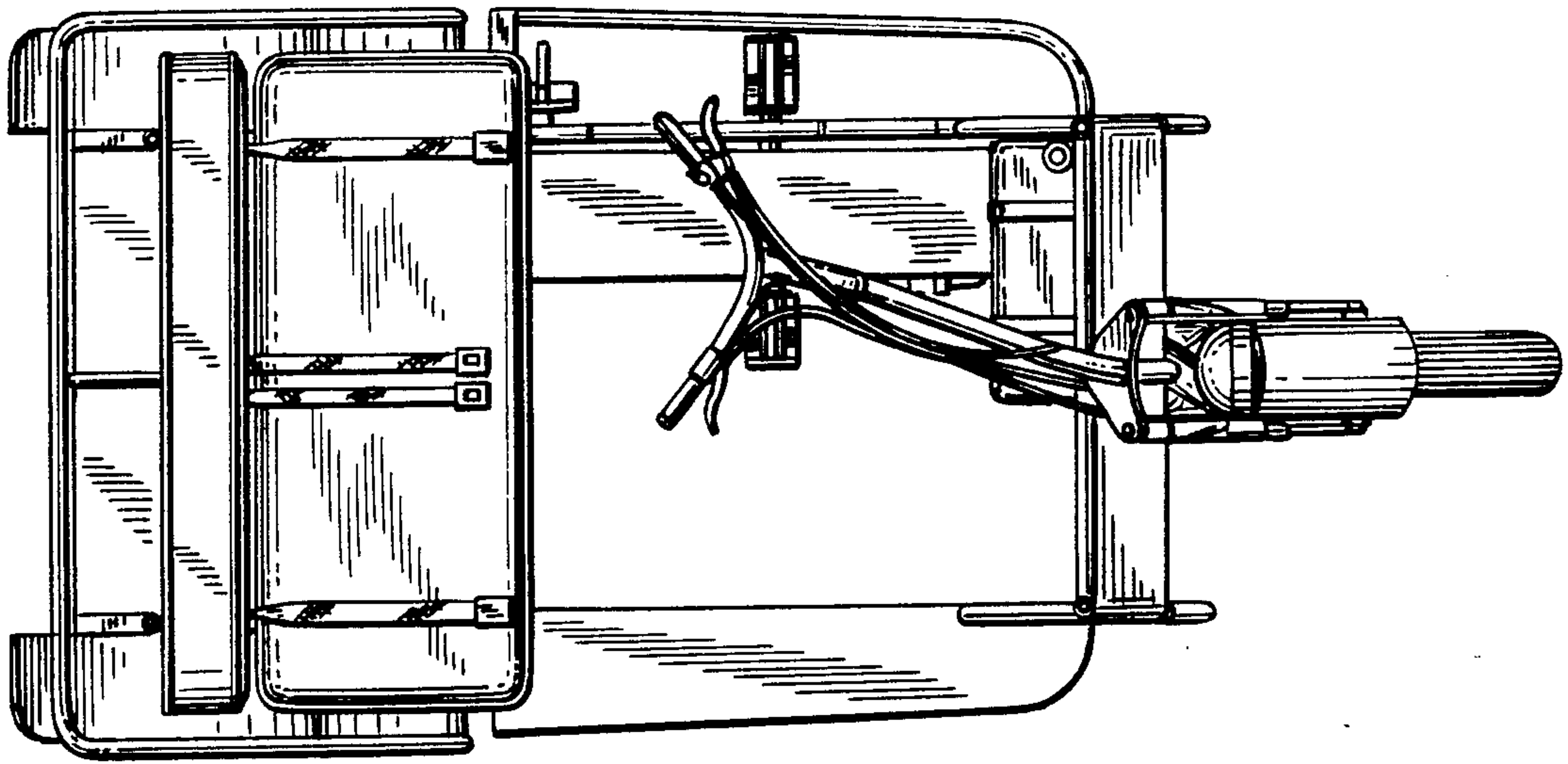

FIG. 2

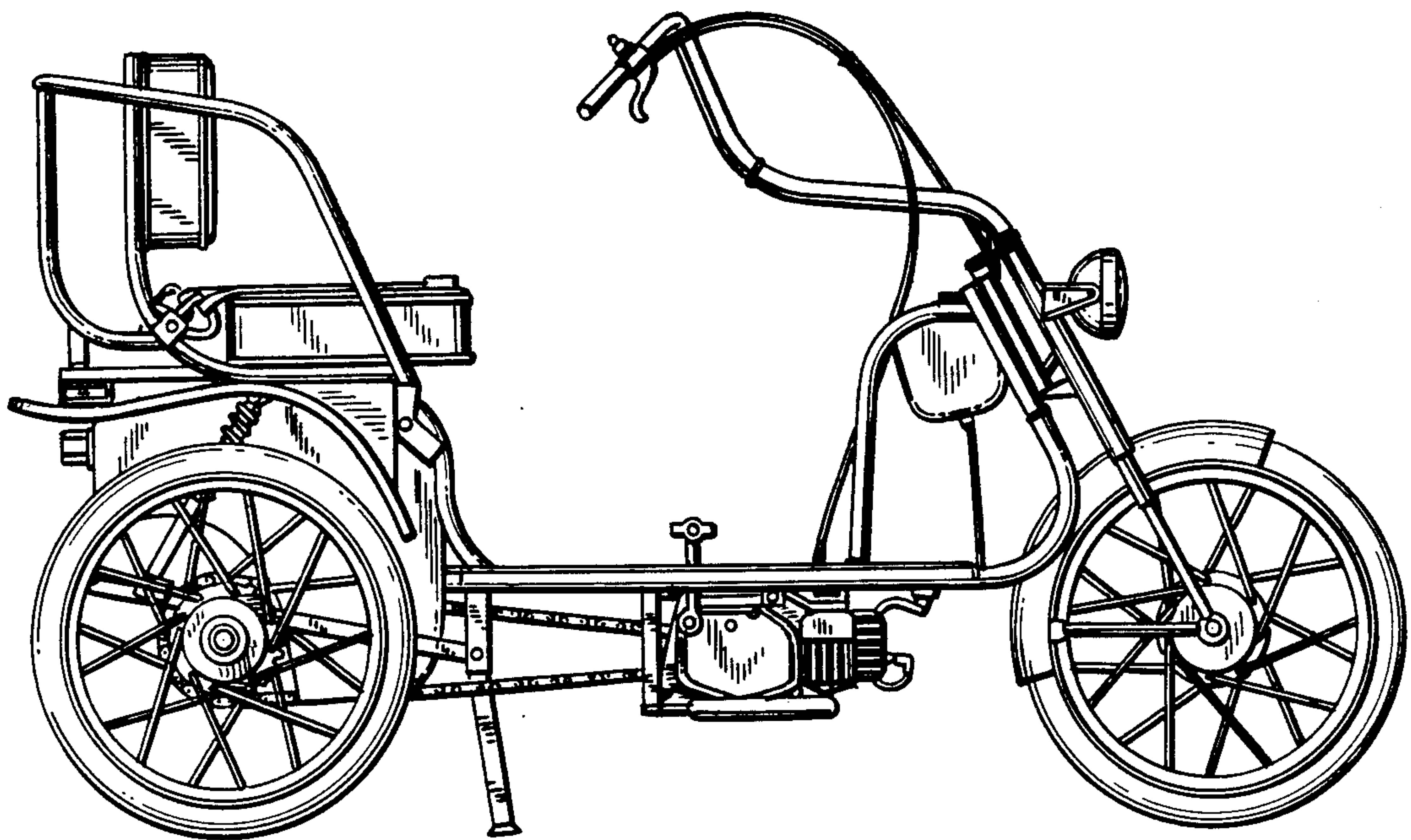

FIG. 3

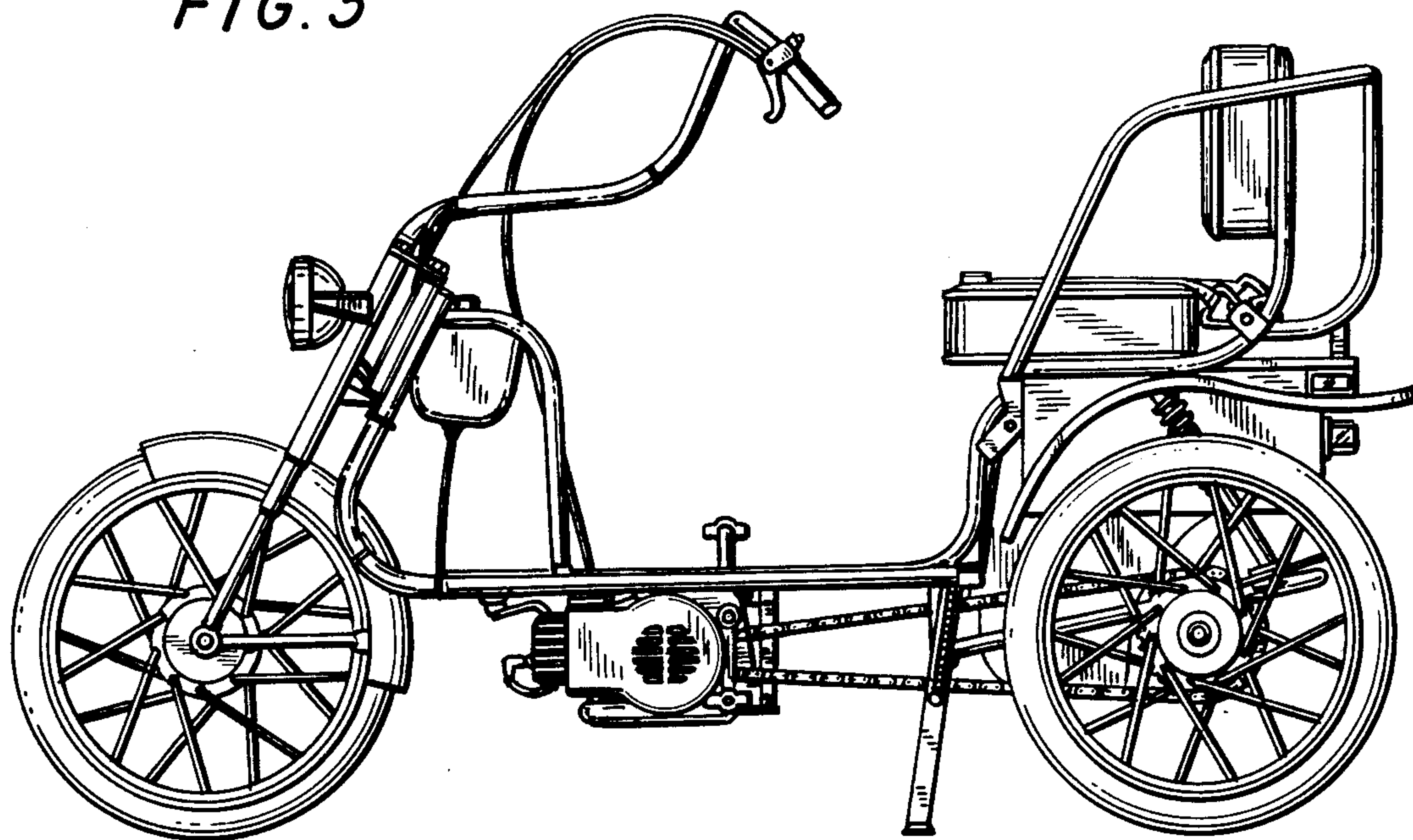

FIG. 4

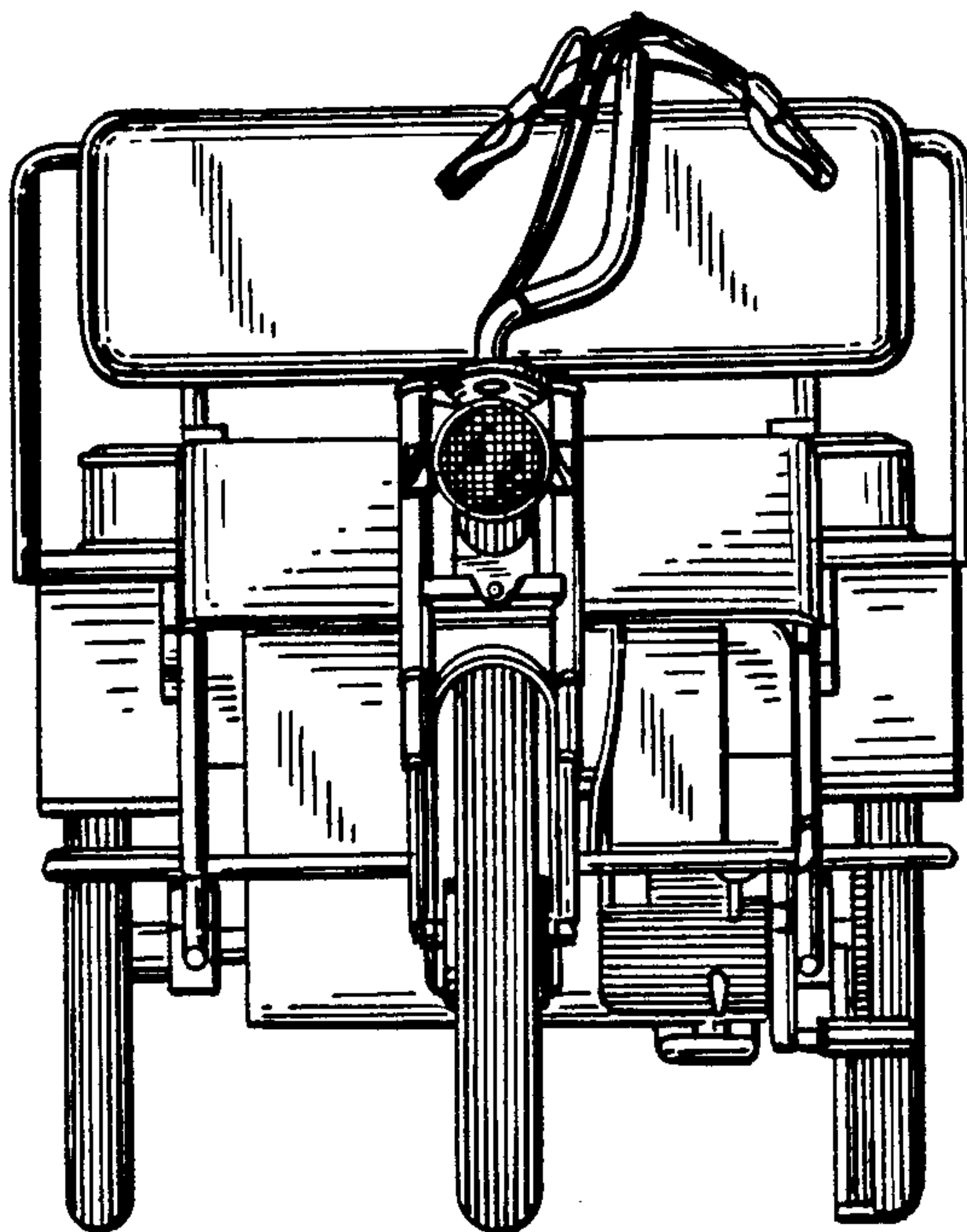

FIG. 5

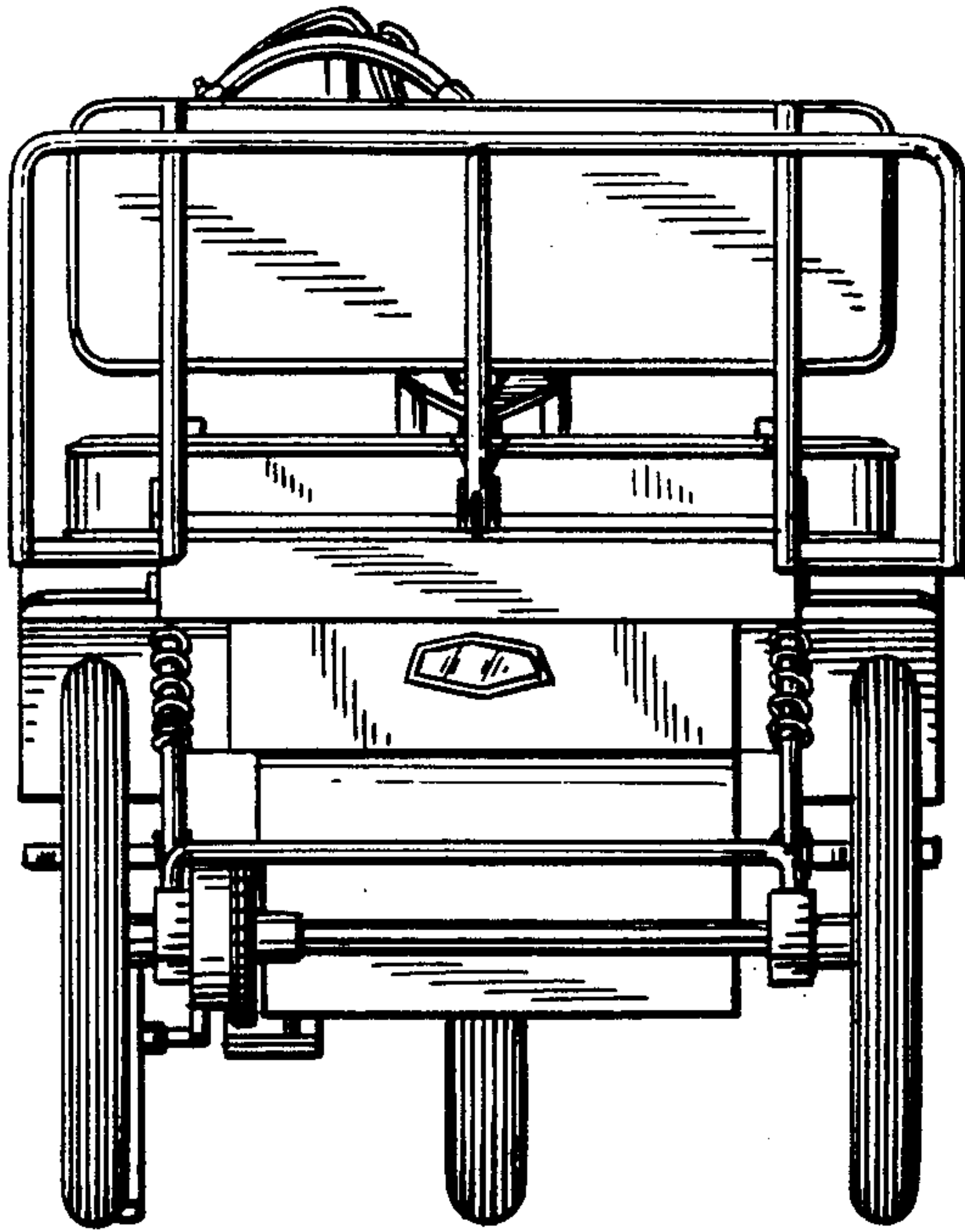

FIG. 6

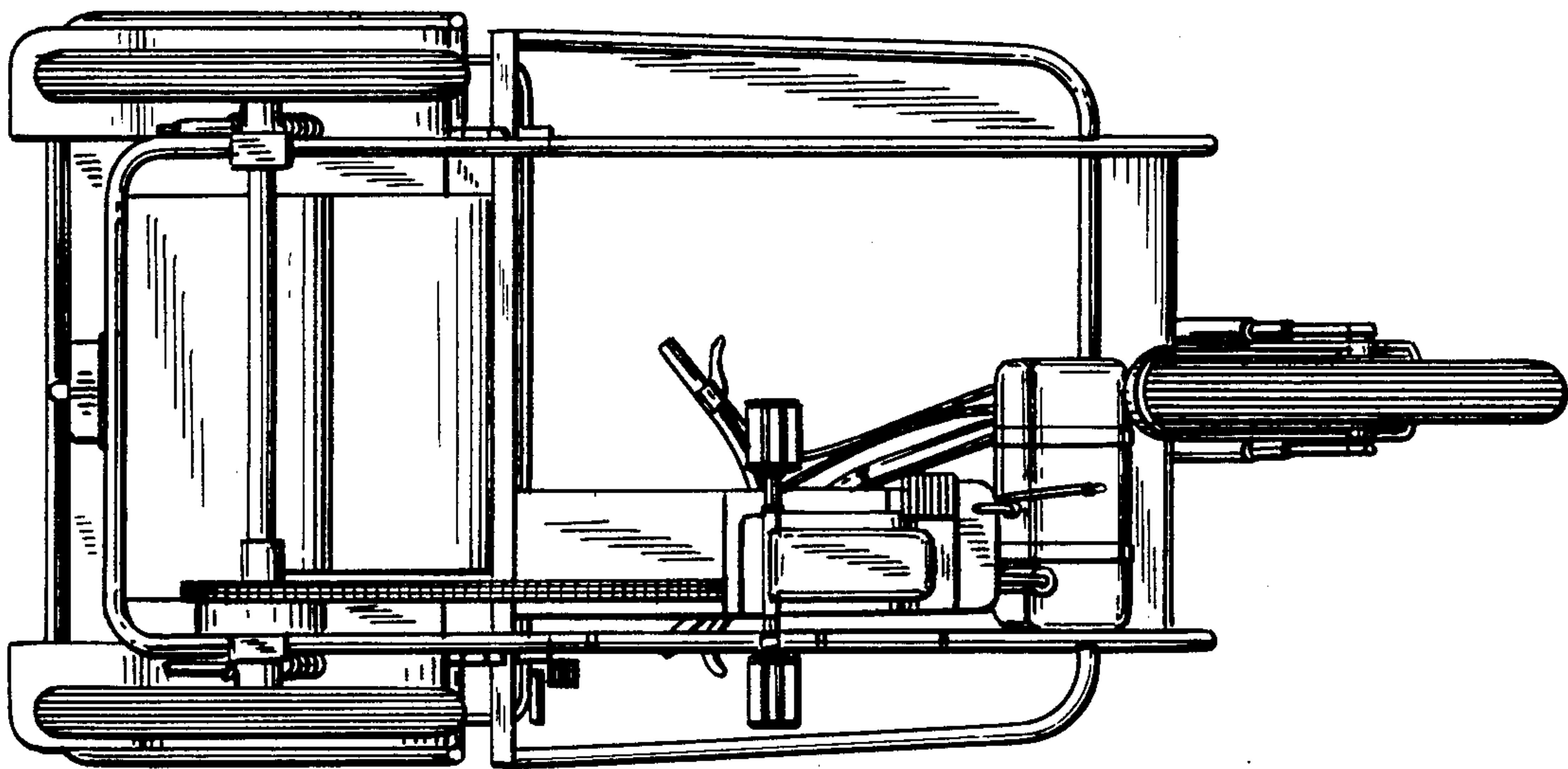

FIG. 7

