

[54] SPORTS CART

[76] Inventors: Charles C. Boisjolie, 2-91st La. NE., Blaine, Minn. 55434; Thomas D. Oakleaf, 1814 E. Cottage Ave., St. Paul, Minn. 55101

[**] Term: 14 Years

[21] Appl. No.: 881,884

[22] Filed: Feb. 27, 1978

[51] Int. Cl. D12-02

[52] U.S. Cl. D12/34

[58] Field of Search D12/32, 33, 34; 280/43.1, 47.13 R, 47.17, 47.19, 47.23, 47.24, 47.26, 79.1 R, 79.1 A, 79.2, 79.3, 639, 652; 211/13, 60 R; 248/129, 128

[56]

References Cited

U.S. PATENT DOCUMENTS

D. 156,810	1/1950	Brownlee	D12/32
D. 166,953	6/1952	Clarke	D12/34
D. 184,838	4/1959	Tucker	D12/32
3,052,484	9/1962	Huffman et al.	280/639

Primary Examiner—James M. Gandy
Attorney, Agent, or Firm—Norman P. Friederichs

[57] CLAIM

The ornamental design for a sports cart, as shown.

DESCRIPTION

FIG. I is a perspective view of a sports cart showing our new design;
FIG. II is a left side elevational view thereof, the right side being substantially a mirror image of the left side shown herein;
FIG. III is a top plan view thereof;
FIG. IV is a bottom plan view thereof;
FIG. V is a front elevational view thereof; and
FIG. VI is a rear elevational view thereof.

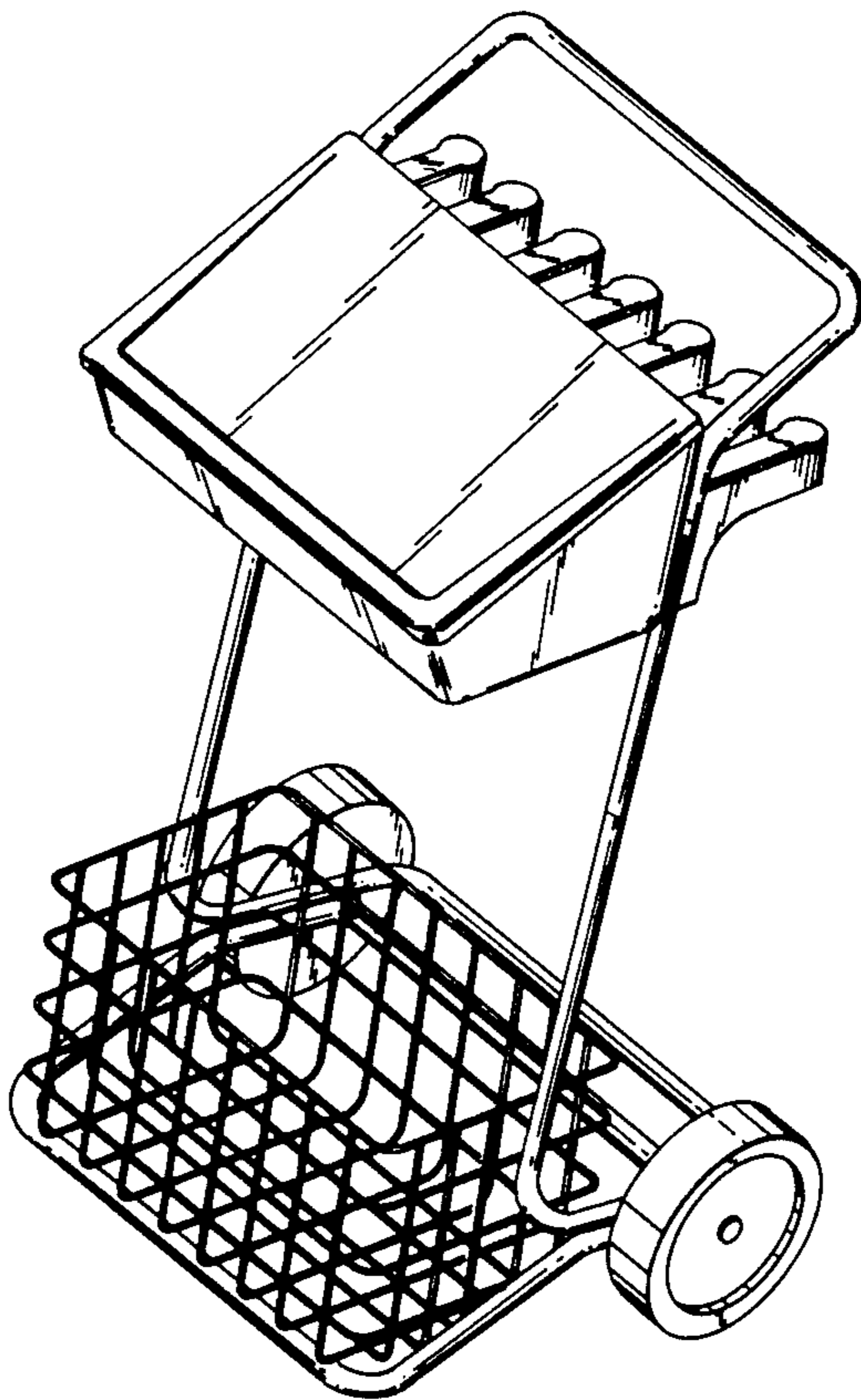

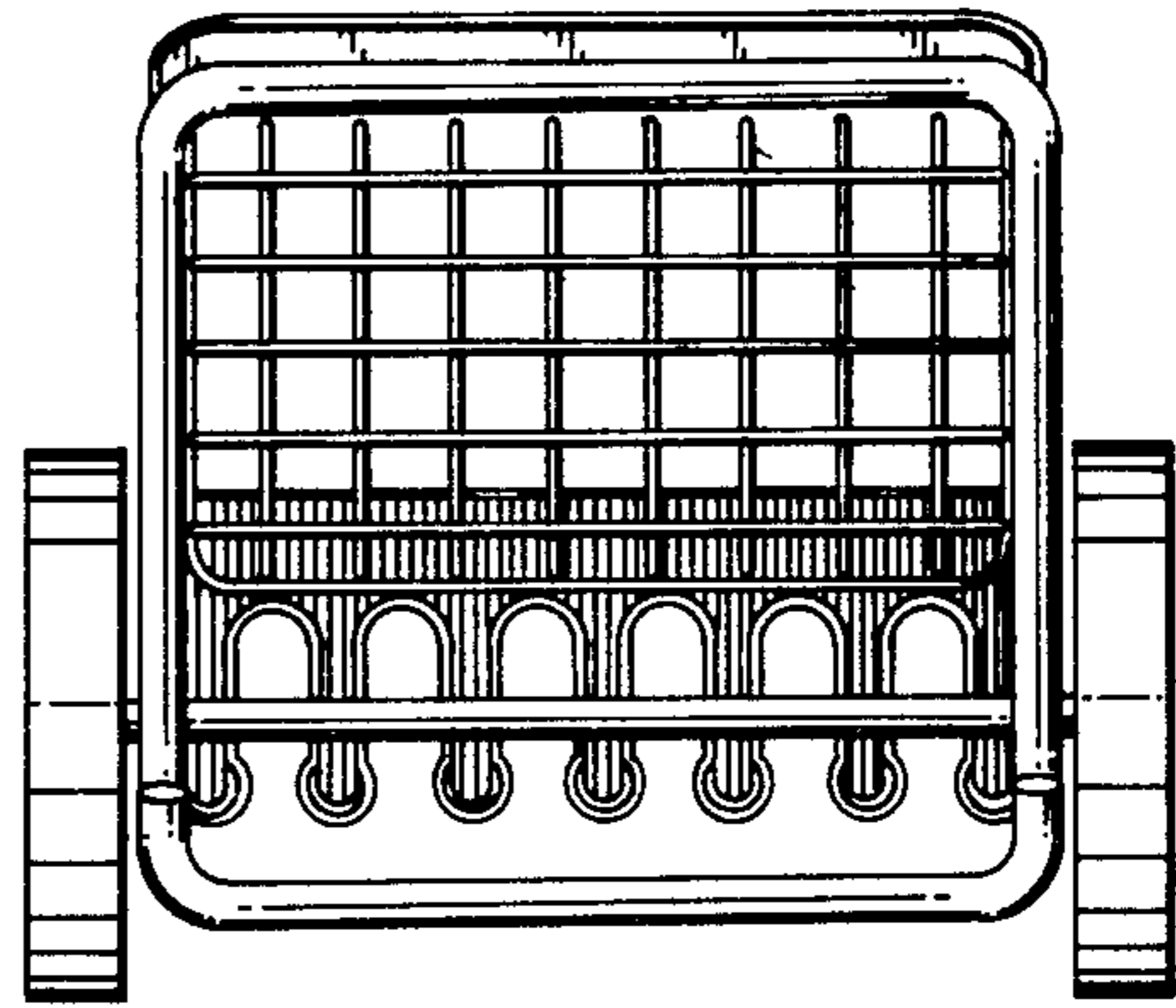
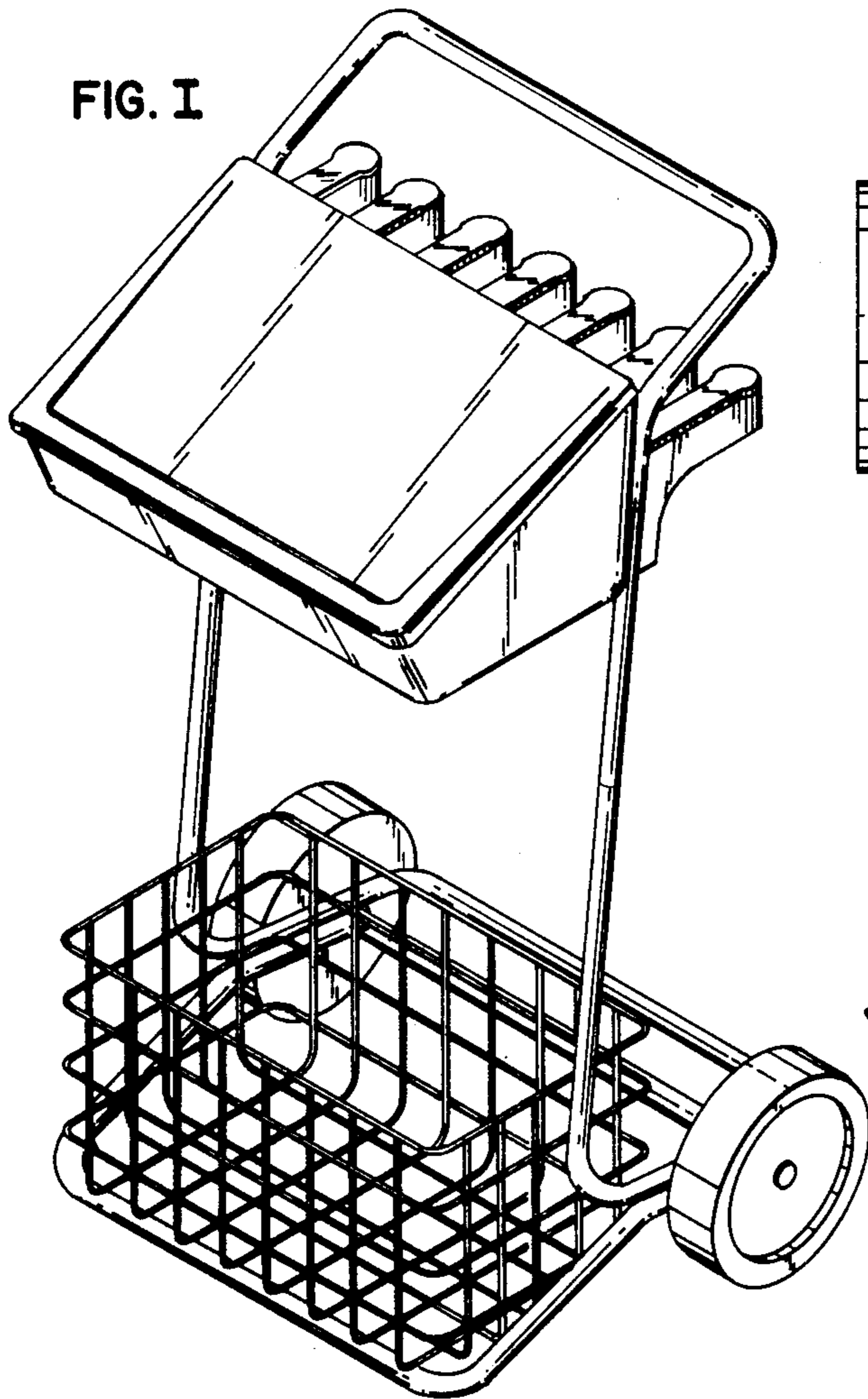

FIG. IV

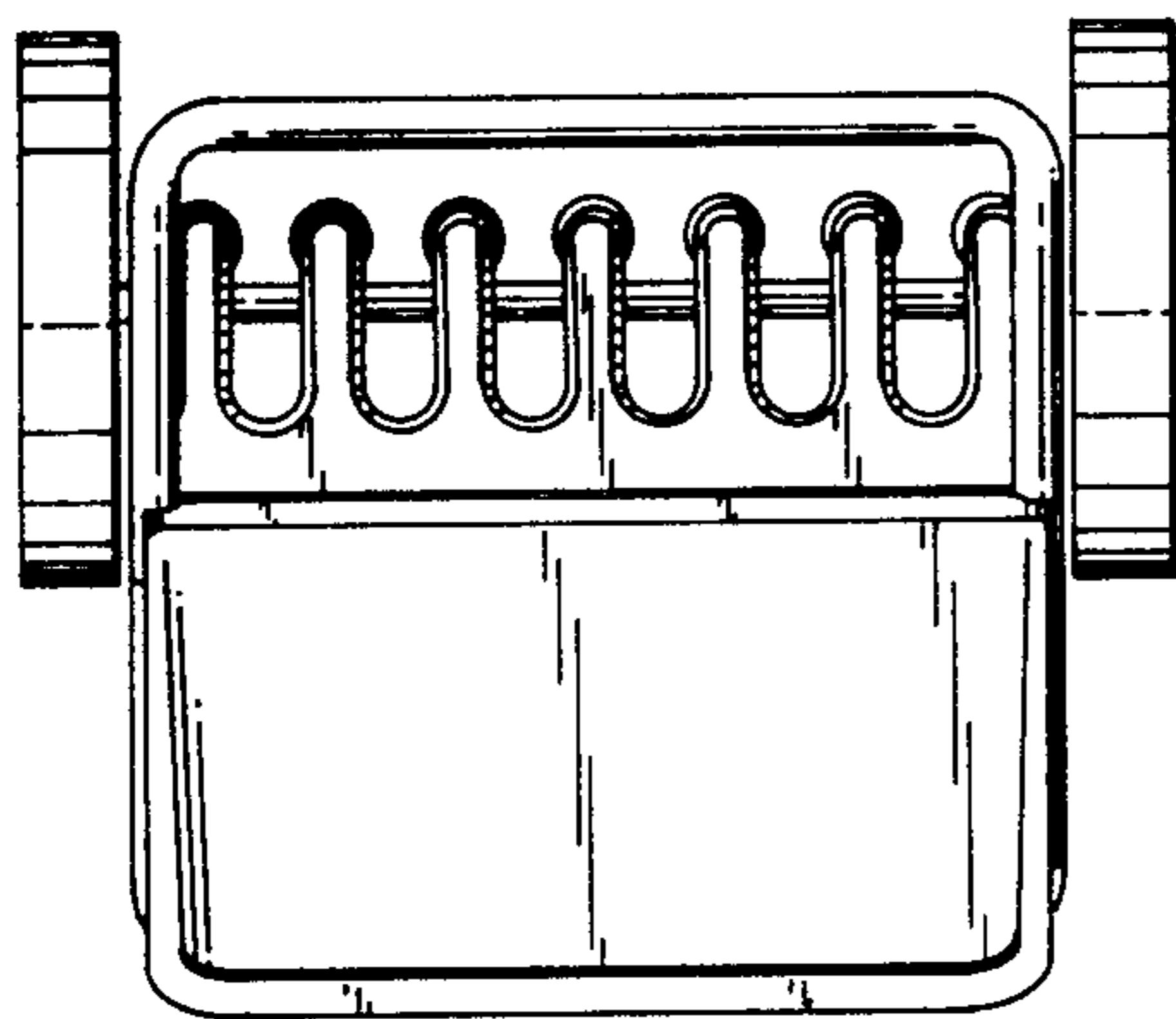

FIG. III

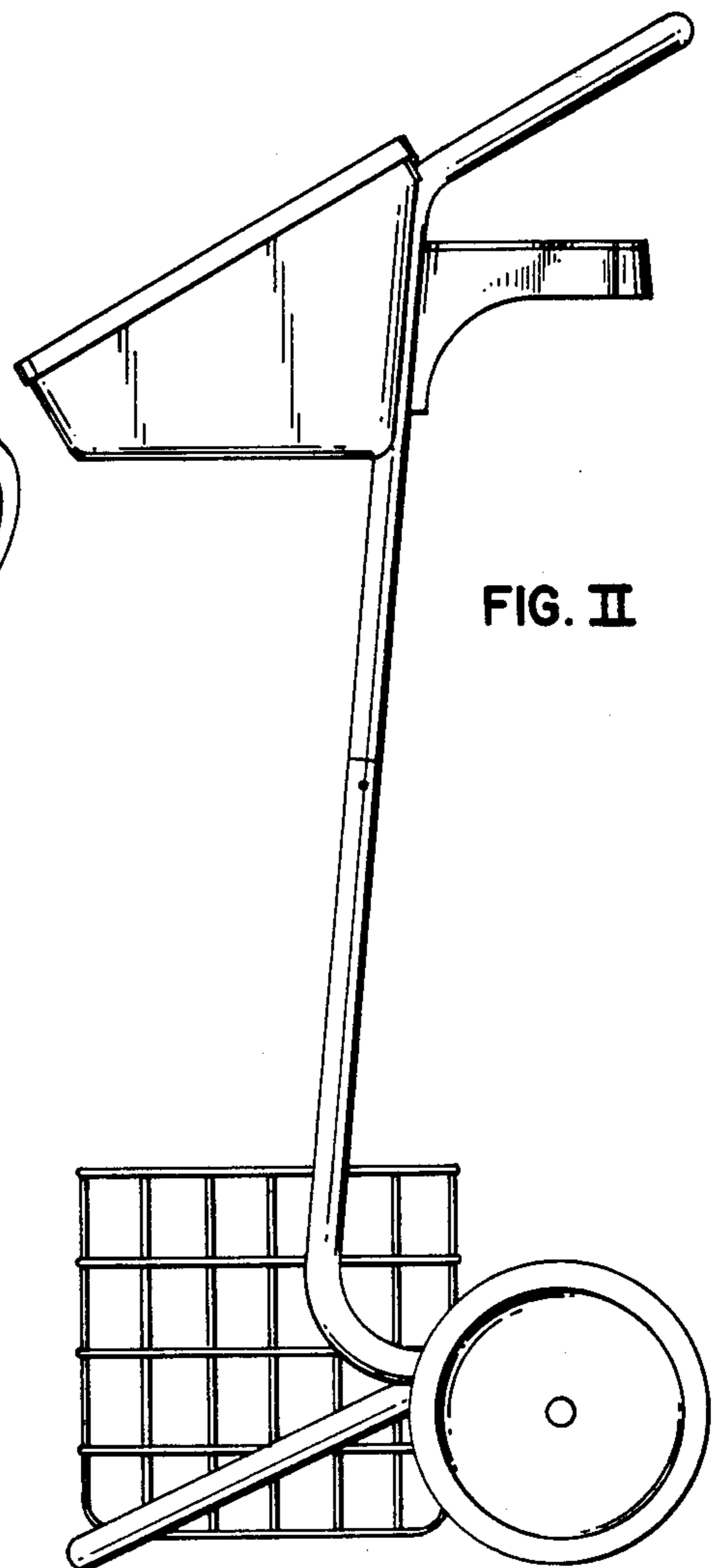

FIG. II

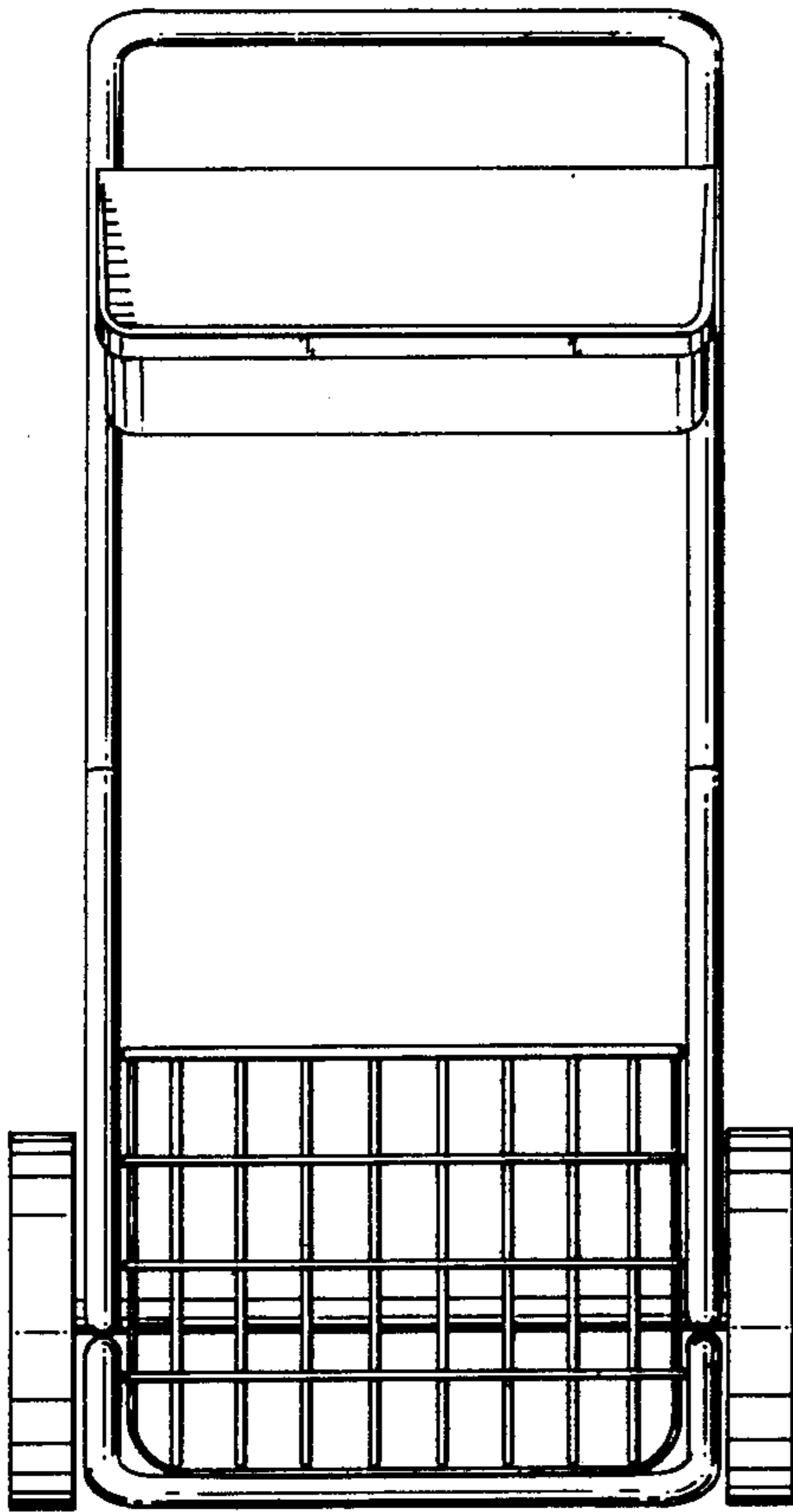

FIG. V

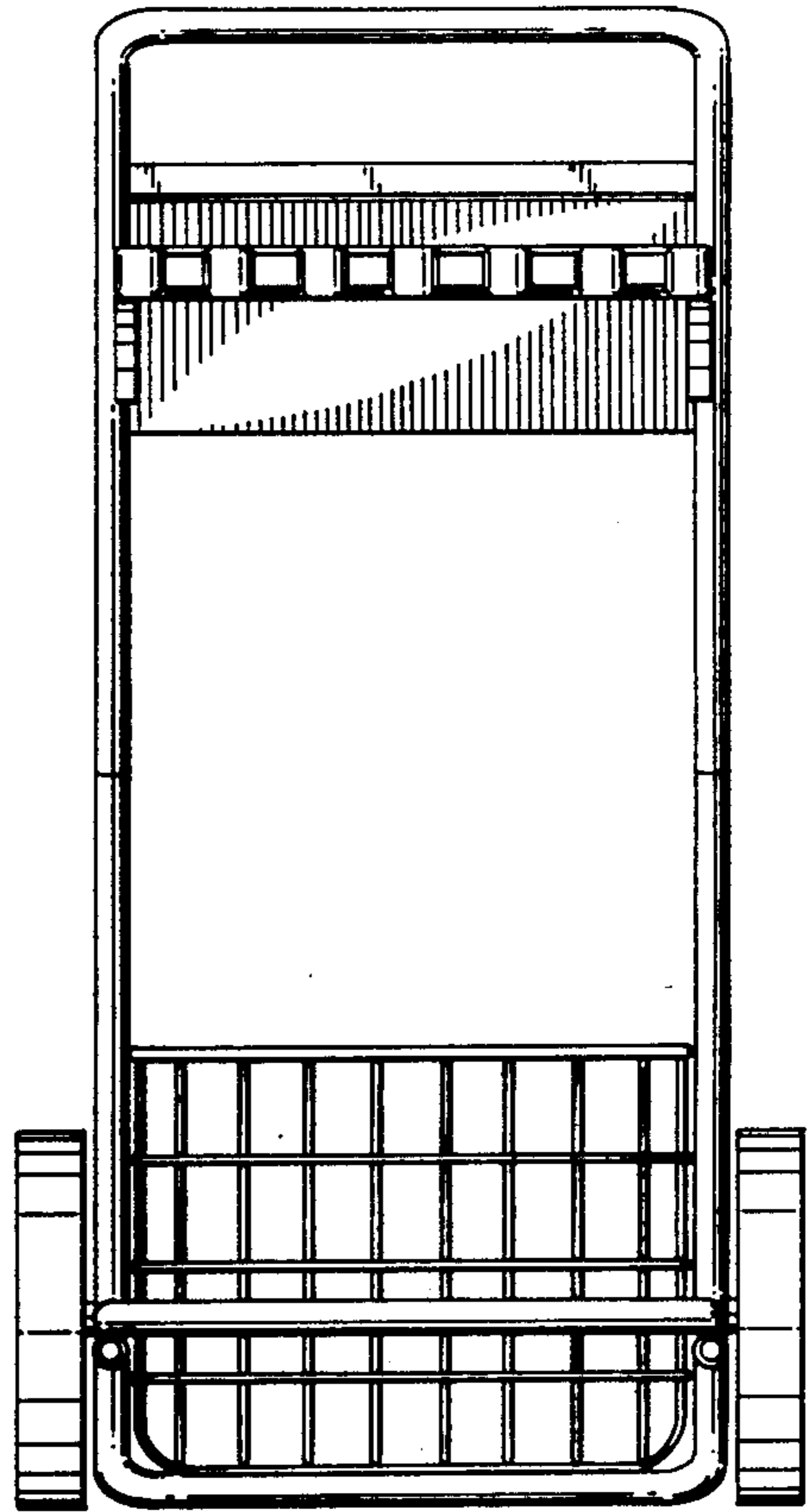

FIG. VI