

[54] SUBMARINE AMUSEMENT GAME CABINET

[75] Inventor: Phillip C. Kearney, Aptos, Calif.

[73] Assignee: Atari, Inc., Sunnyvale, Calif.

[\*\*] Term: 14 Years

[21] Appl. No.: 869,869

[22] Filed: Jan. 16, 1978

[51] Int. Cl. .... D21-03

[52] U.S. Cl. .... D21/01

[58] Field of Search ..... D34/5 R, 5 N, 5 J; 273/DIG. 28, 101.1, 101.2; 35/12 N

[56] References Cited

U.S. PATENT DOCUMENTS

2,497,003	2/1950	Larson	273/101.2
3,782,728	1/1974	Yasuda	273/101.2

OTHER PUBLICATIONS

Vending Times, Mar. 1977, p. 61, middle right, "Sea Wolf" Cabinet.

Primary Examiner—Melvin B. Feifer  
Attorney, Agent, or Firm—Stephen S. Townsend

[57] CLAIM

The ornamental design for a submarine amusement game cabinet, as shown and described.

DESCRIPTION

FIG. 1 is a perspective view of a submarine amusement game cabinet showing my new design.

FIG. 2 is a right side-elevational view of the game cabinet, which view is symmetrical to the left side-elevational view of the game.

FIG. 3 is a front-elevational view of the game cabinet.

FIG. 4 is a rear-elevational view of the game cabinet.

FIG. 5 is a top plan view of the game cabinet.

FIG. 6 is a cross-sectional plan view taken along the line 6-6 of FIG. 2.

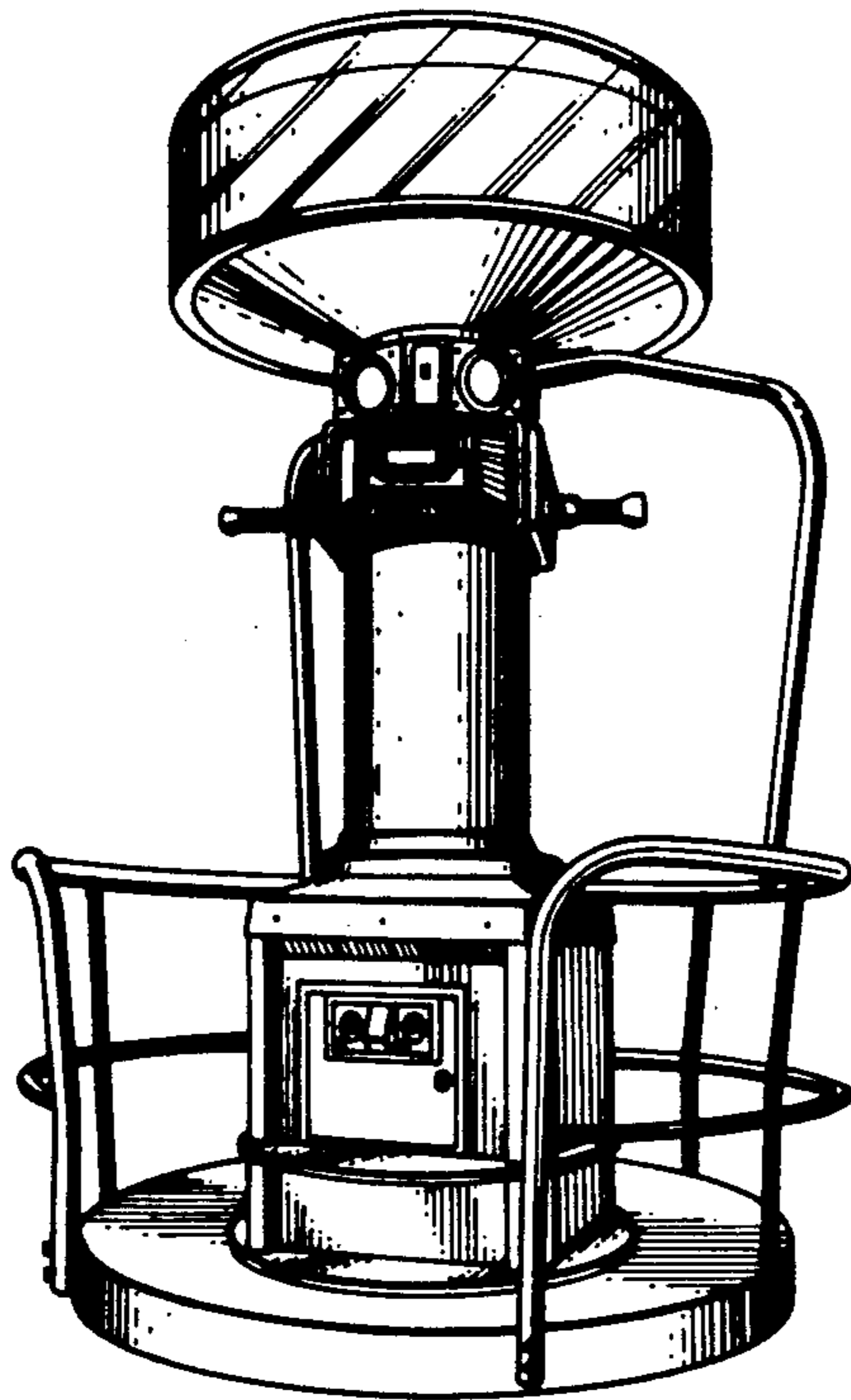

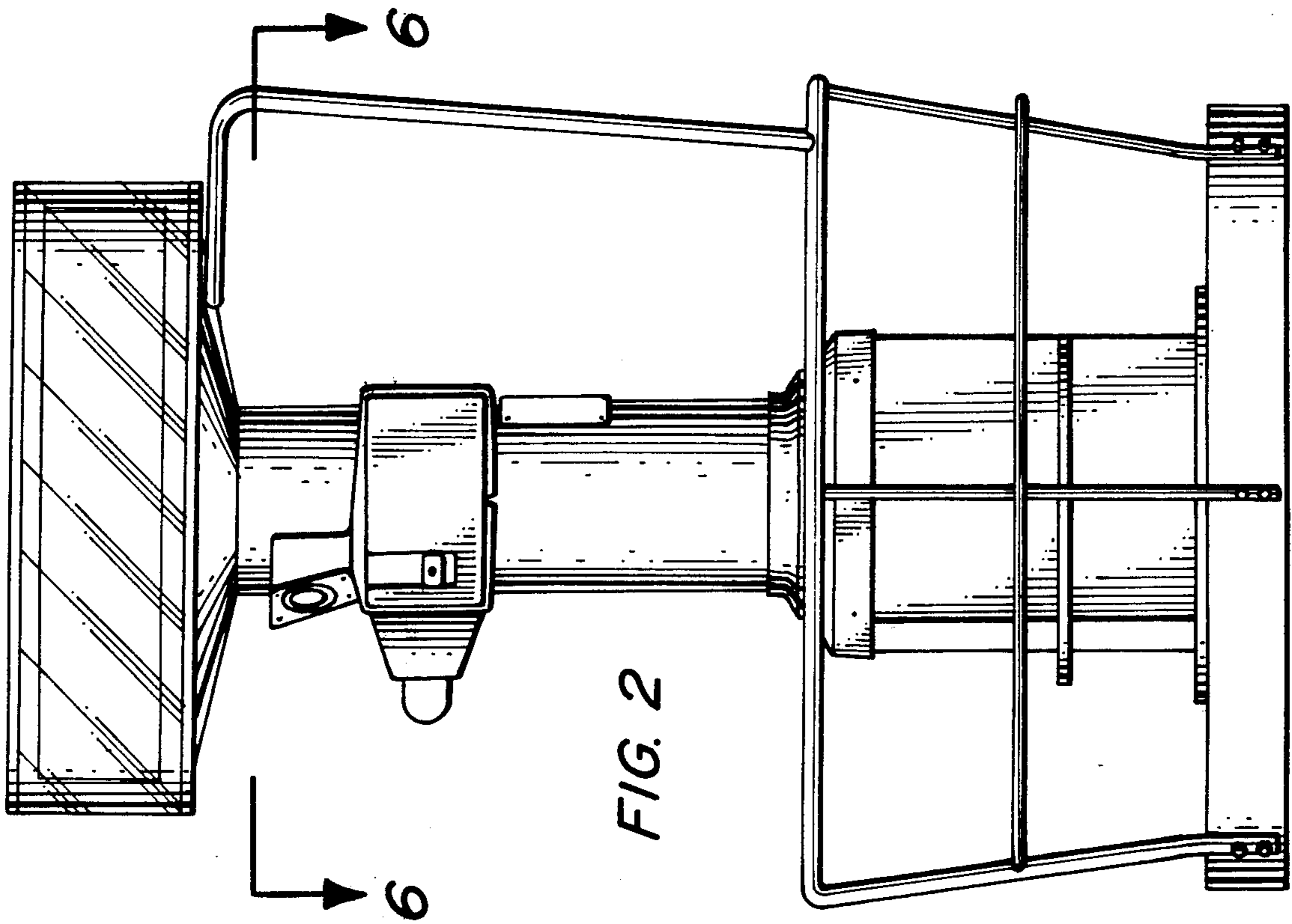

FIG. 2

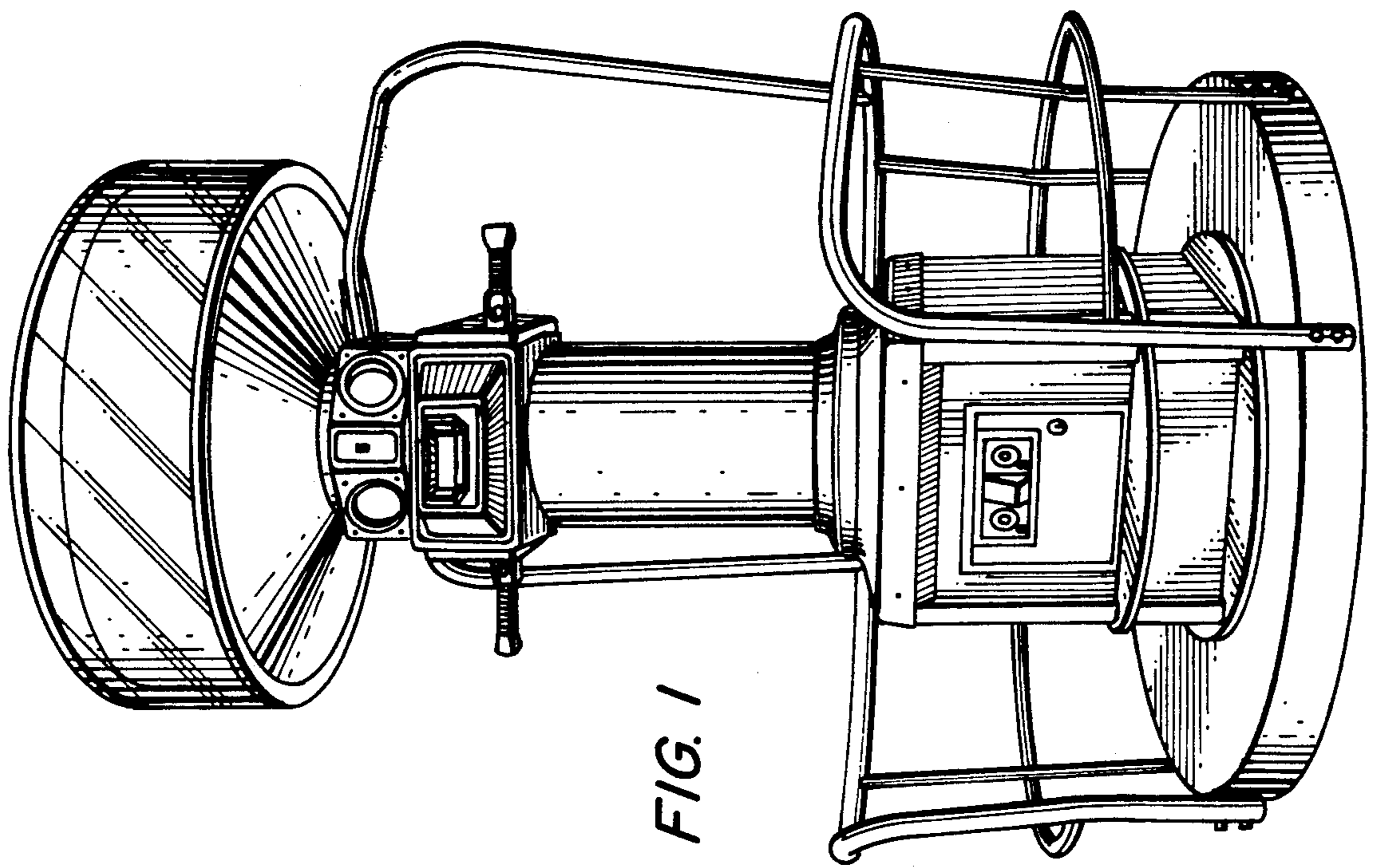
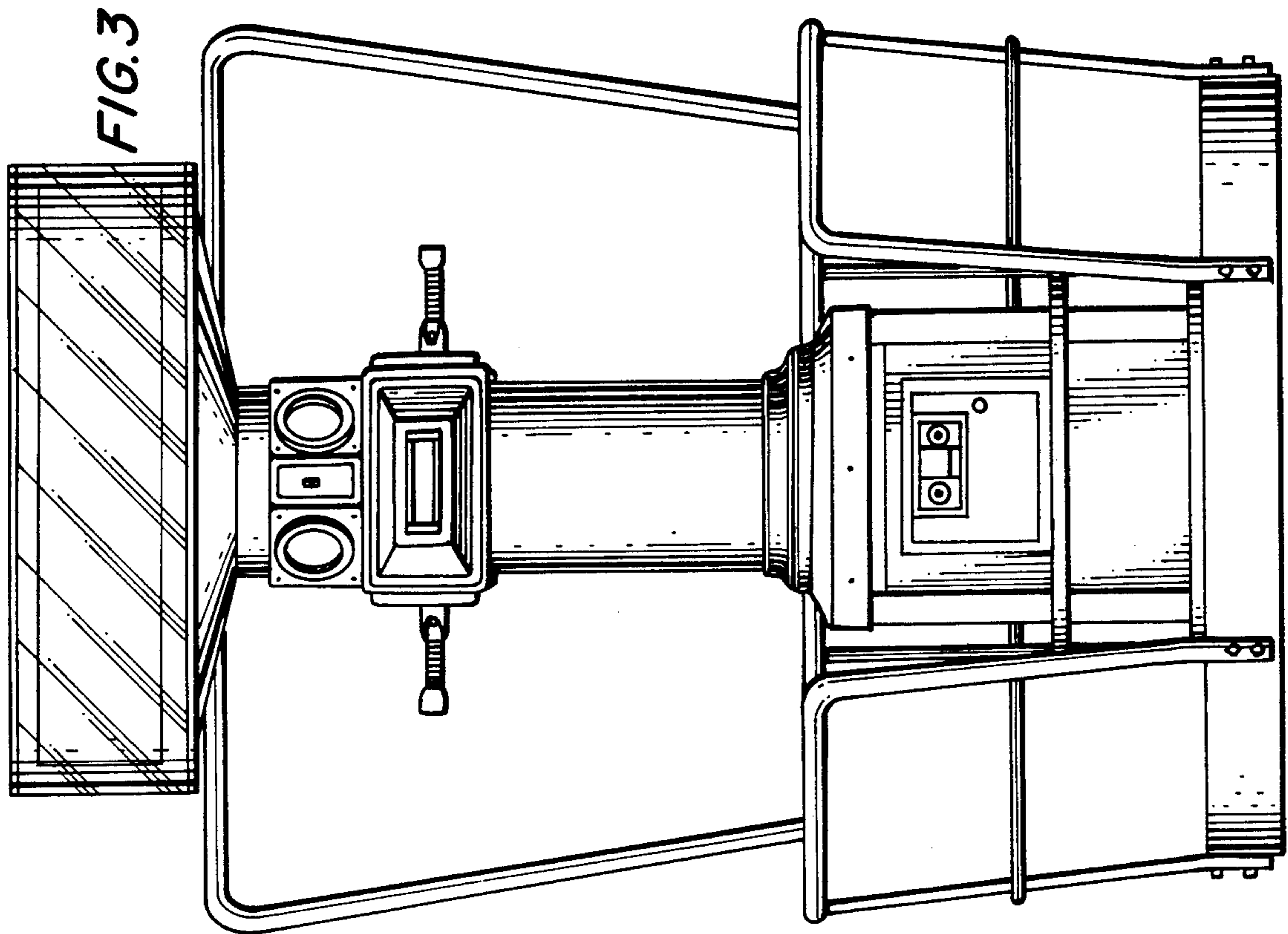
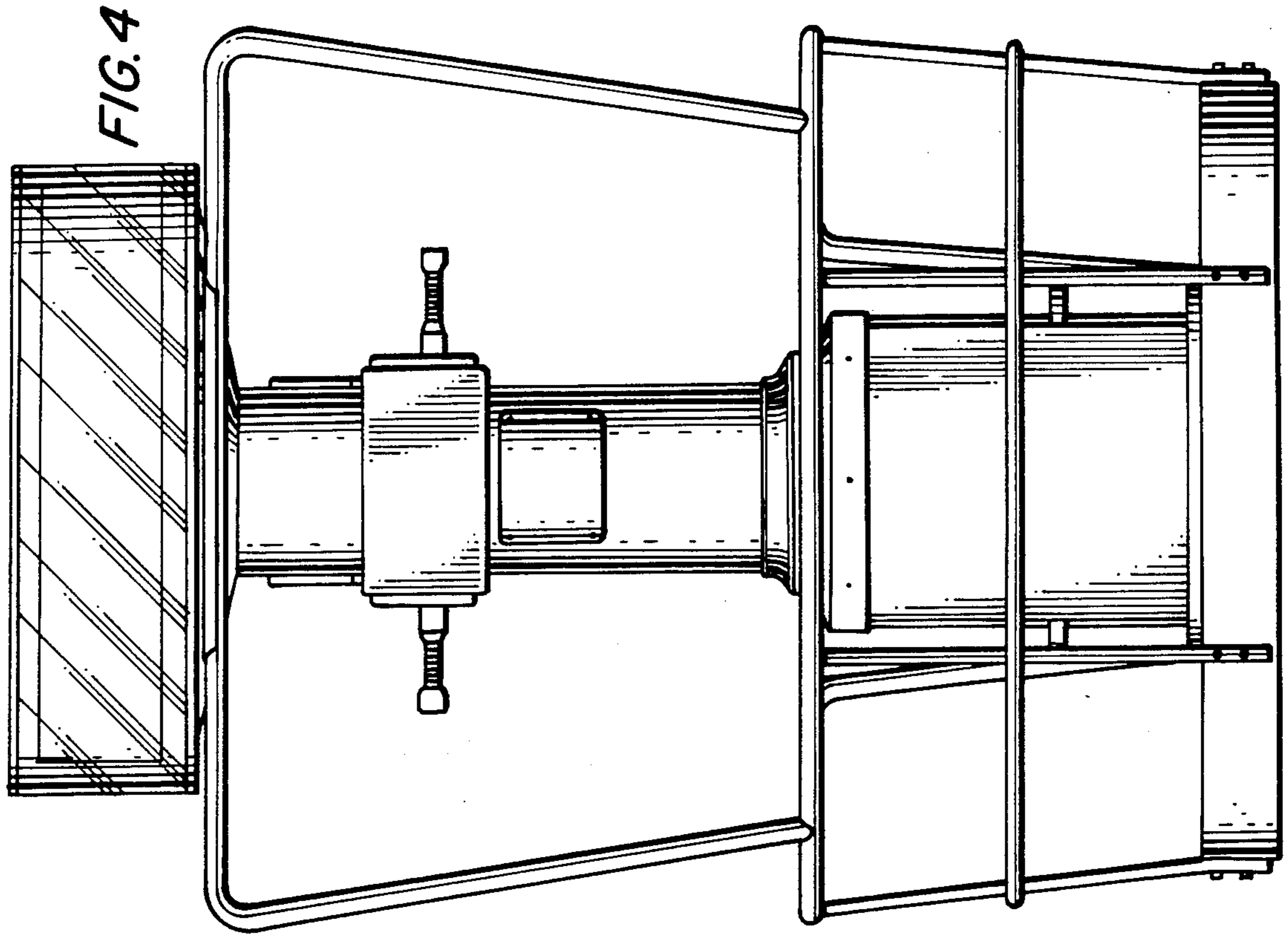

FIG. 1





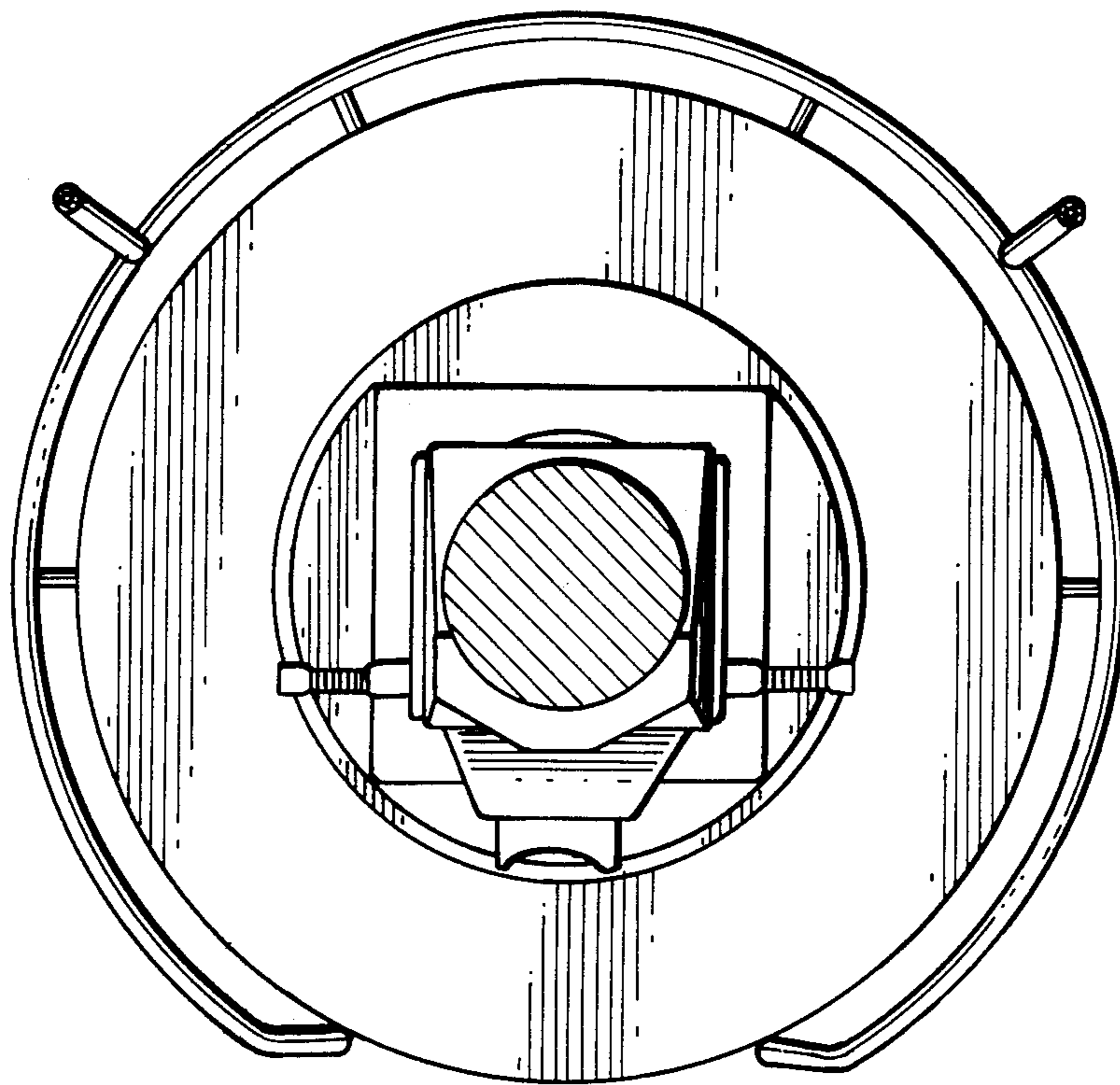

FIG. 6

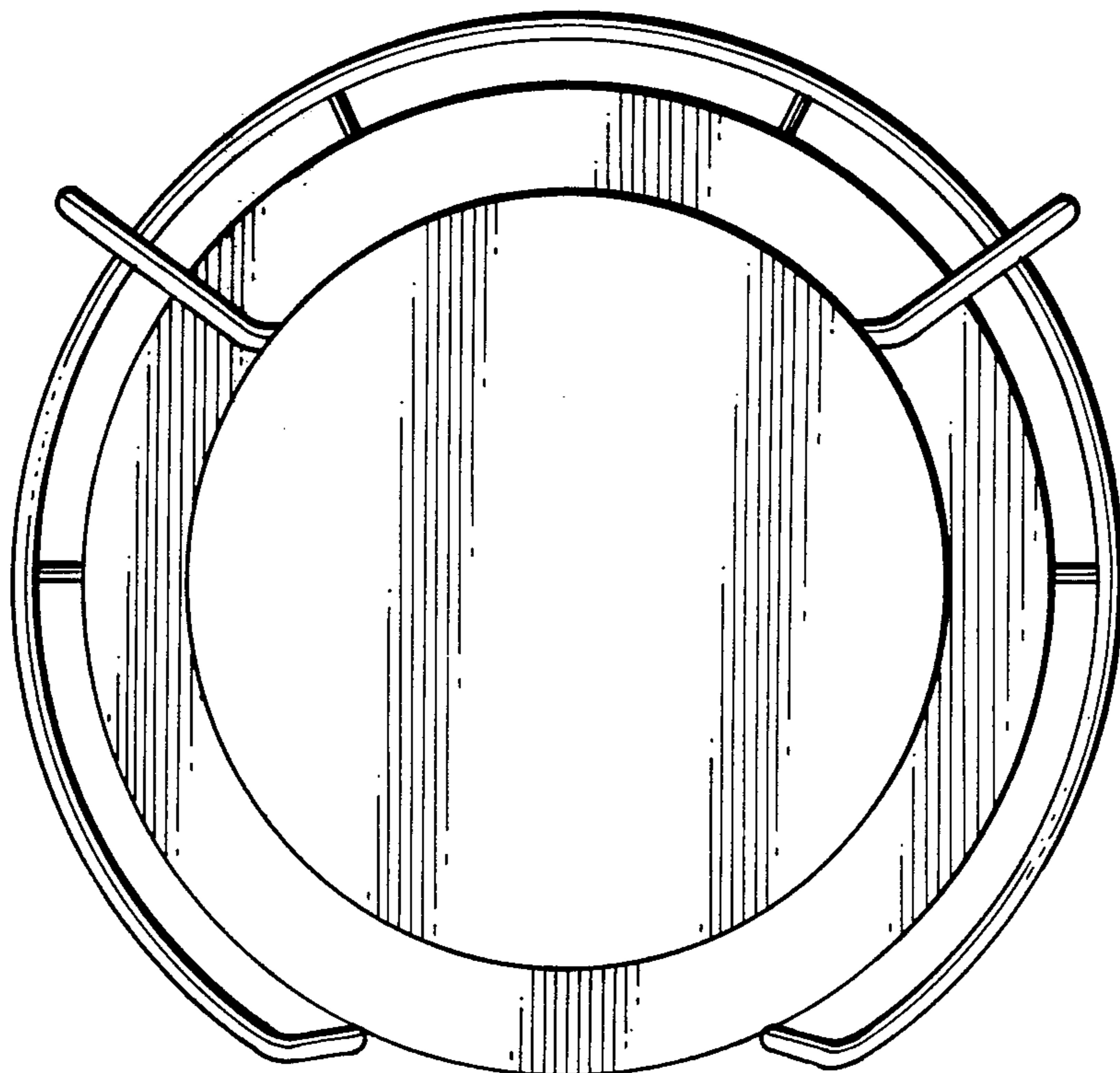

FIG. 5