

[54] CART

[75] Inventors: Stephen A. Bacskay, Bloomington; Sidney Messeri, West Orange, both of N.J.

[73] Assignees: Outlook In Plastics Corporation, Inc.; Tingue, Brown & Co.; a part interest to each

[\*\*] Term: 14 Years

[21] Appl. No.: 887,591

[22] Filed: Mar. 17, 1978

[51] Int. Cl. .... D12-02

[52] U.S. Cl. .... D12/27; D12/25

[58] Field of Search .... D12/25, 27, 29; 280/47.34, 47.35, 47.33, 79.1 R, 79.1 A, 79.2, 79.3; D15/163, 194

[56] References Cited

U.S. PATENT DOCUMENTS

D. 213,360 2/1969 McClure ..... D12/29

OTHER PUBLICATIONS

A Purchasing Guide for Materials Handling, Industrial & Safety Equipment, p. 25, 1 3/4 Cubic Yard Tilt Truck, center right side of page.

Primary Examiner—James M. Gandy

Attorney, Agent, or Firm—Cyrus D. Samuelson

[57] CLAIM

The ornamental design of a cart, substantially as shown and described.

DESCRIPTION

FIG. 1 is a top plan view of a cart showing our new design; FIG. 2 is a front elevational view of FIG. 1; FIG. 3 is a rear elevational view of FIG. 1; FIG. 4 is a right side elevational view of FIG. 1; FIG. 5 is a left side elevational view of FIG. 1; FIG. 6 is a bottom plan view of FIG. 1; FIG. 7 is a top plan view of the cart shown in FIG. 1 in fully open condition; FIG. 8 is a front elevational view of FIG. 7; FIG. 9 is a rear elevational view of FIG. 7; FIG. 10 is a right side elevational view of FIG. 7; FIG. 11 is a left side elevational view of FIG. 7; FIG. 12 is a bottom plan view of FIG. 7; FIG. 13 is a top plan view of a cart showing a second embodiment of our new design; FIG. 14 is a front elevational view of FIG. 13; FIG. 15 is a rear elevational view of FIG. 13; FIG. 16 is a right side elevational view of FIG. 13; FIG. 17 is a left side elevational view of FIG. 13; and FIG. 18 is a bottom plan view of FIG. 13.

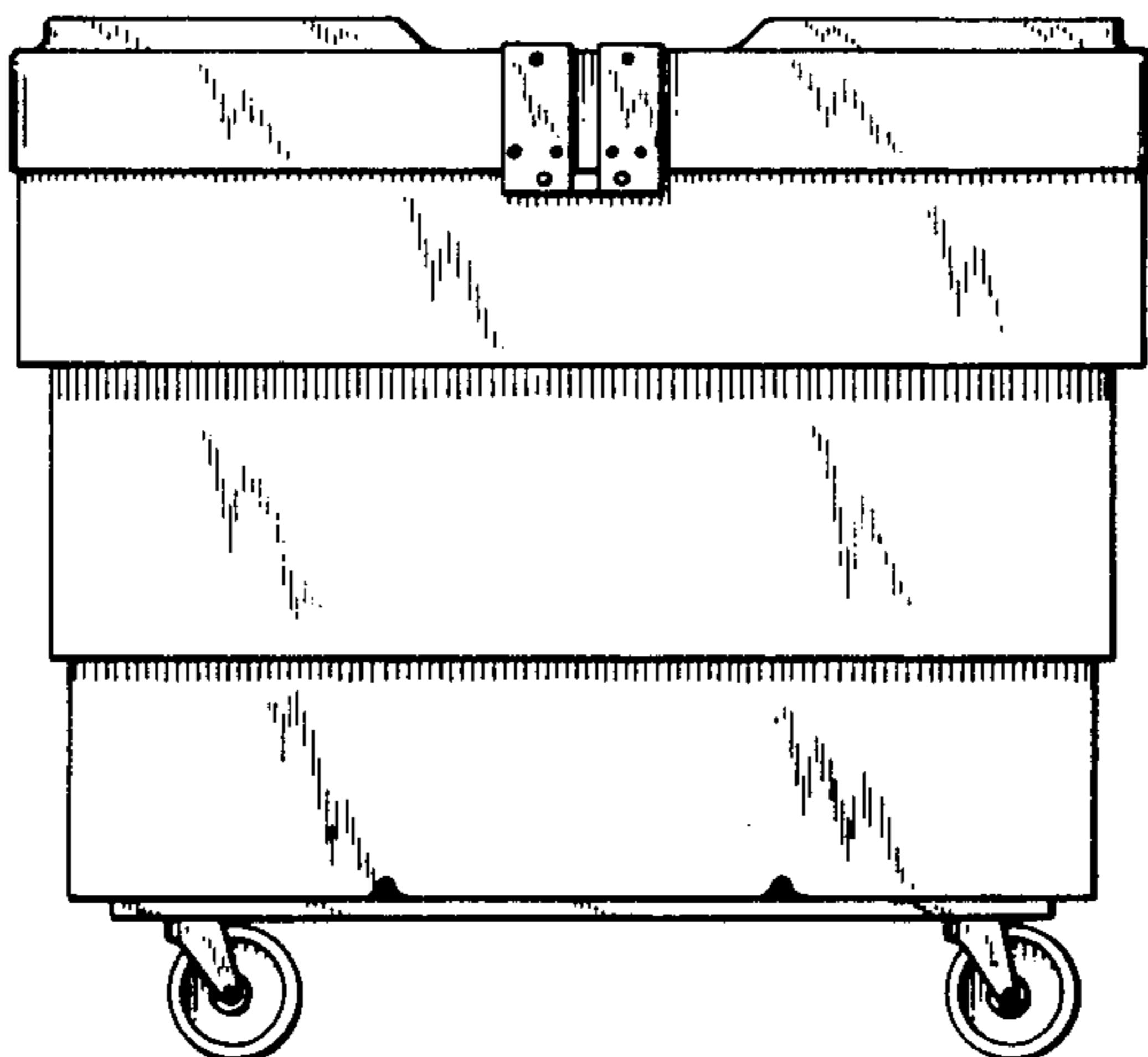
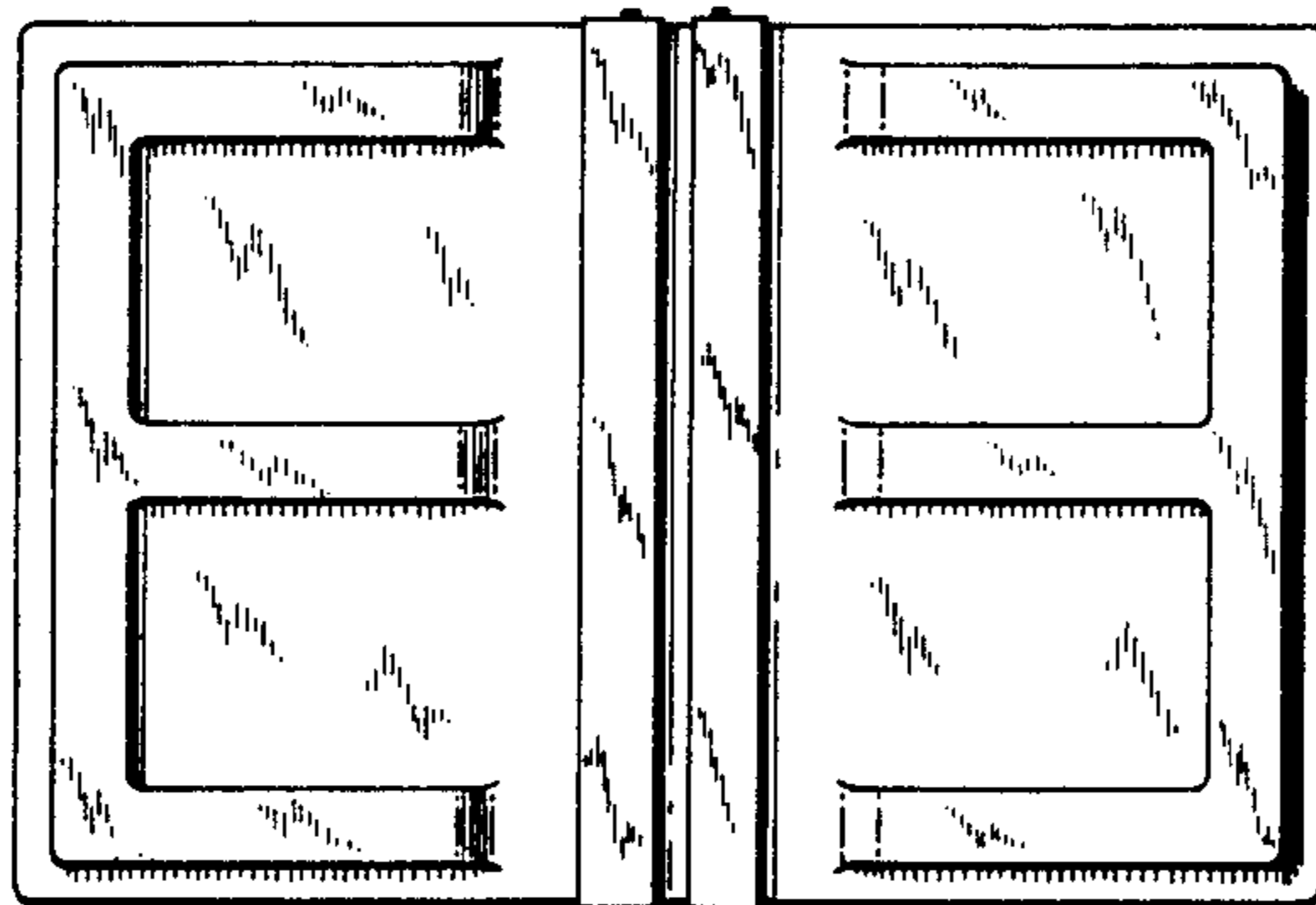

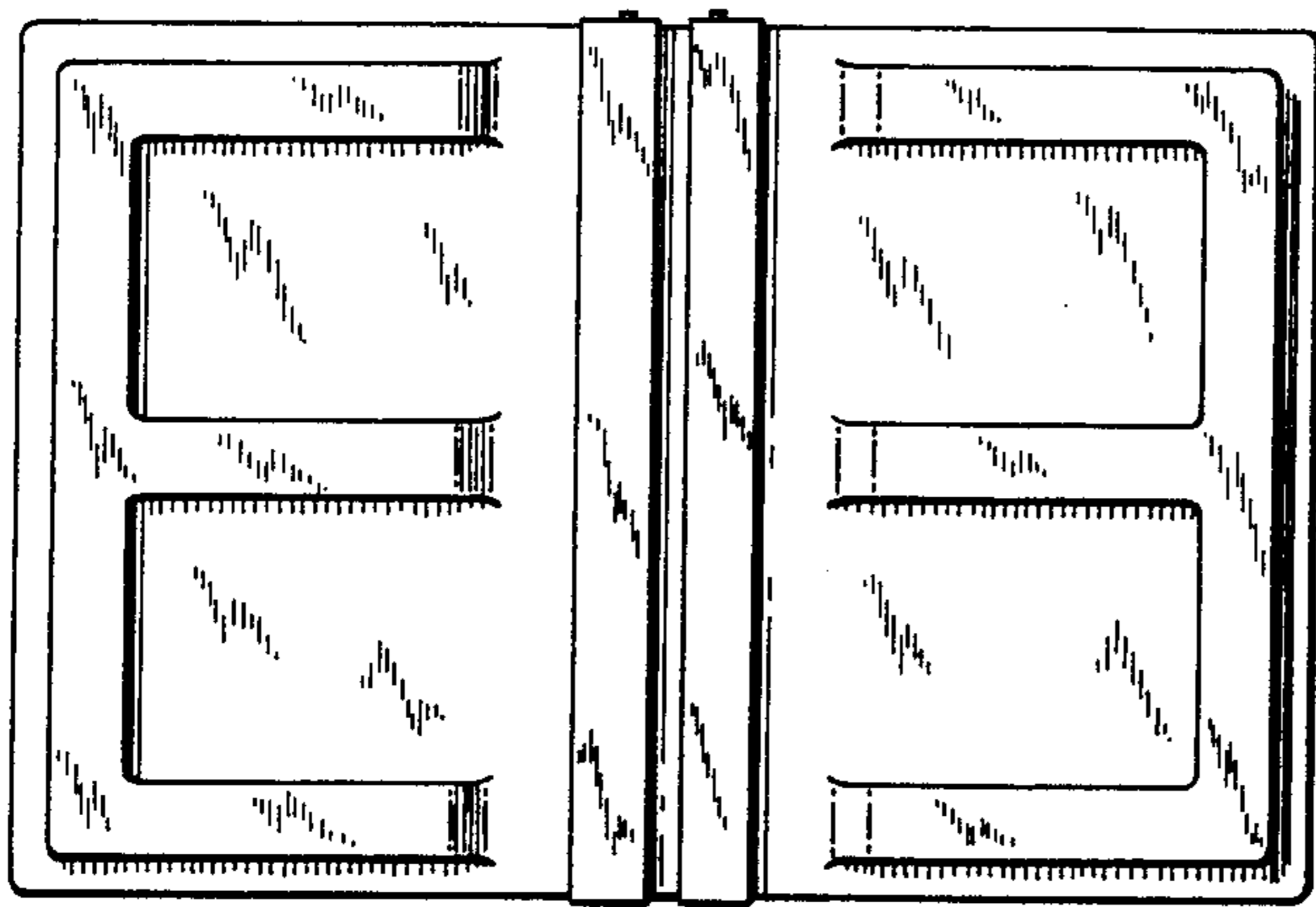

FIG. 1

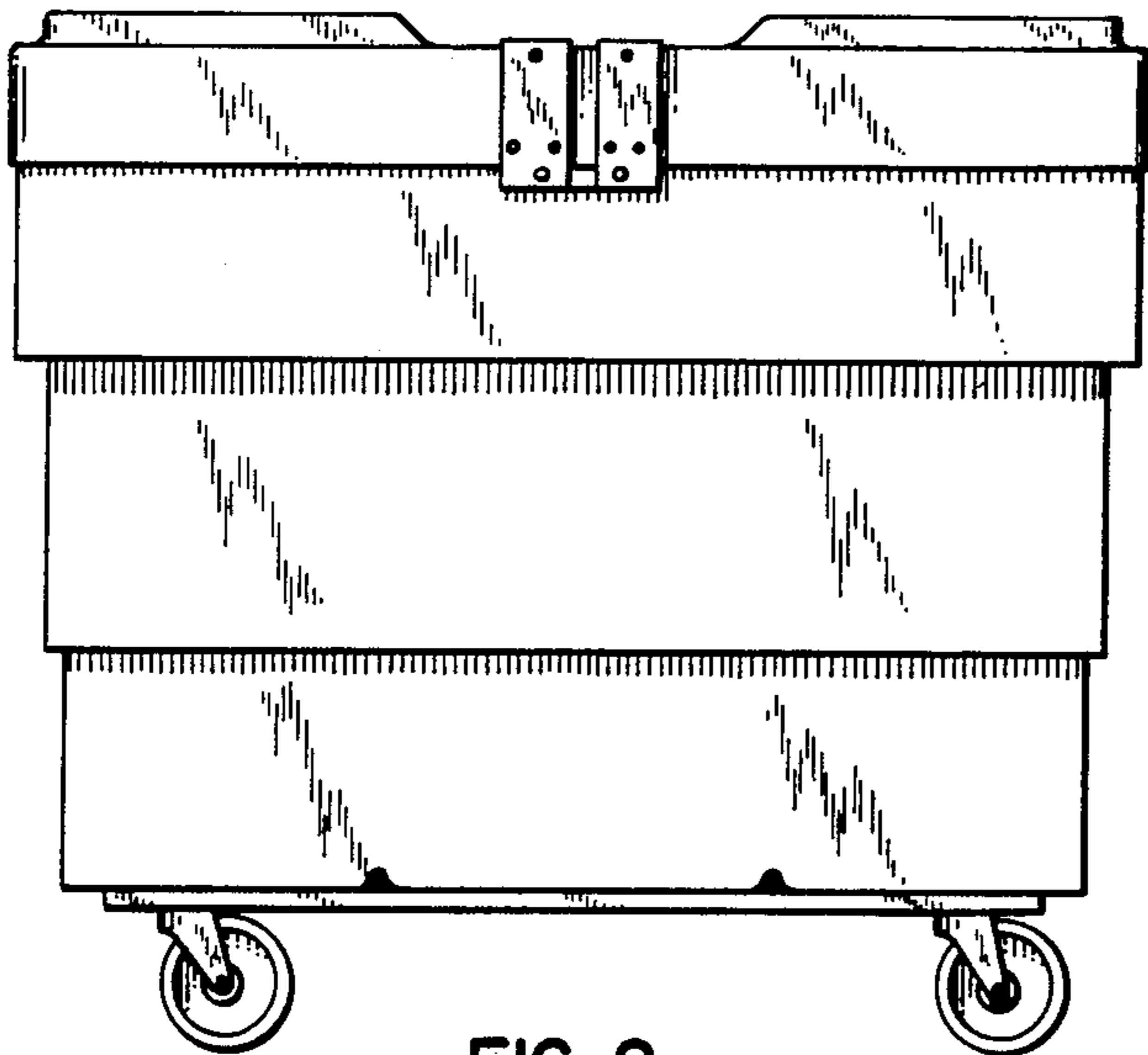

FIG. 2

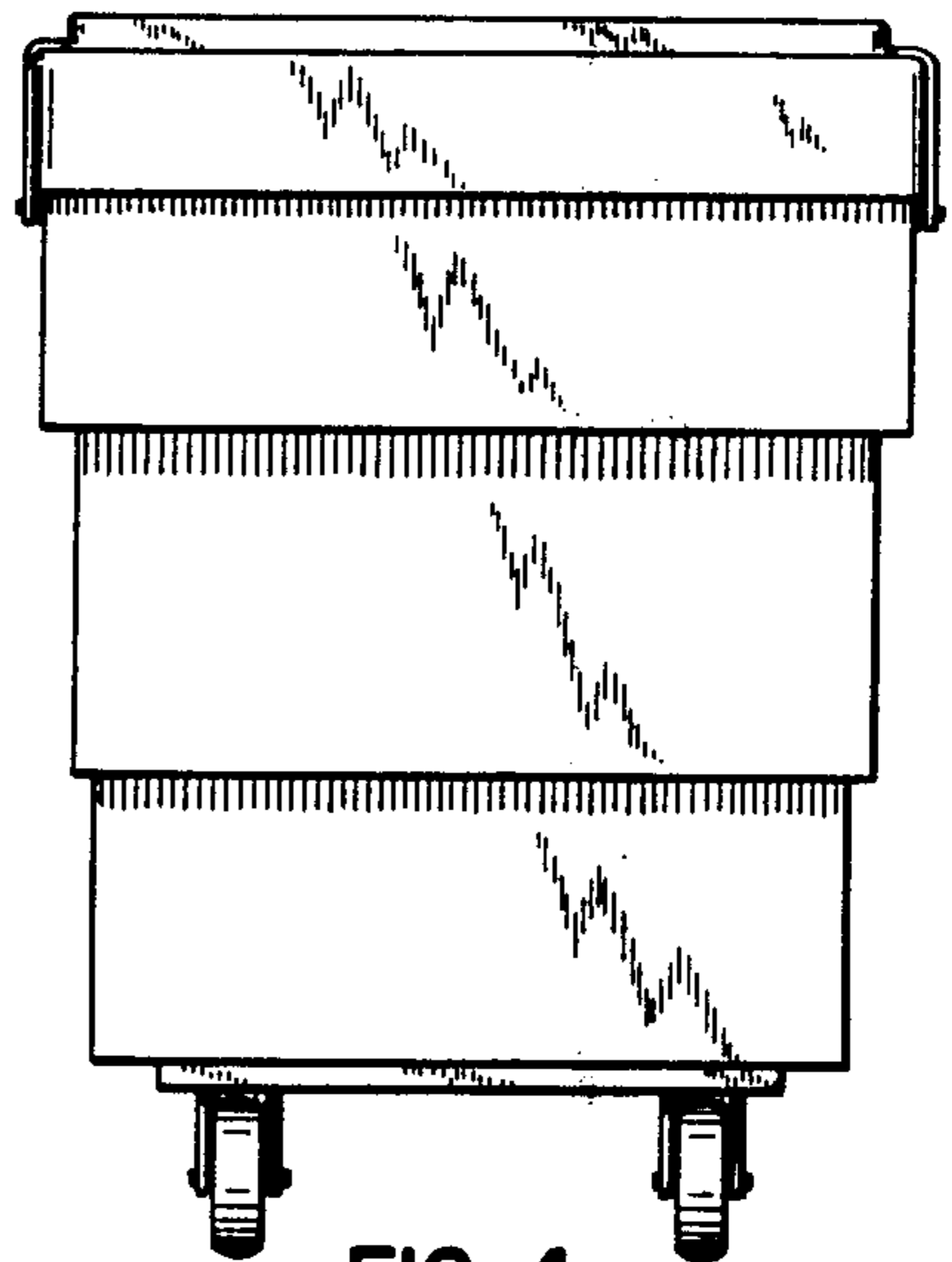

FIG. 4

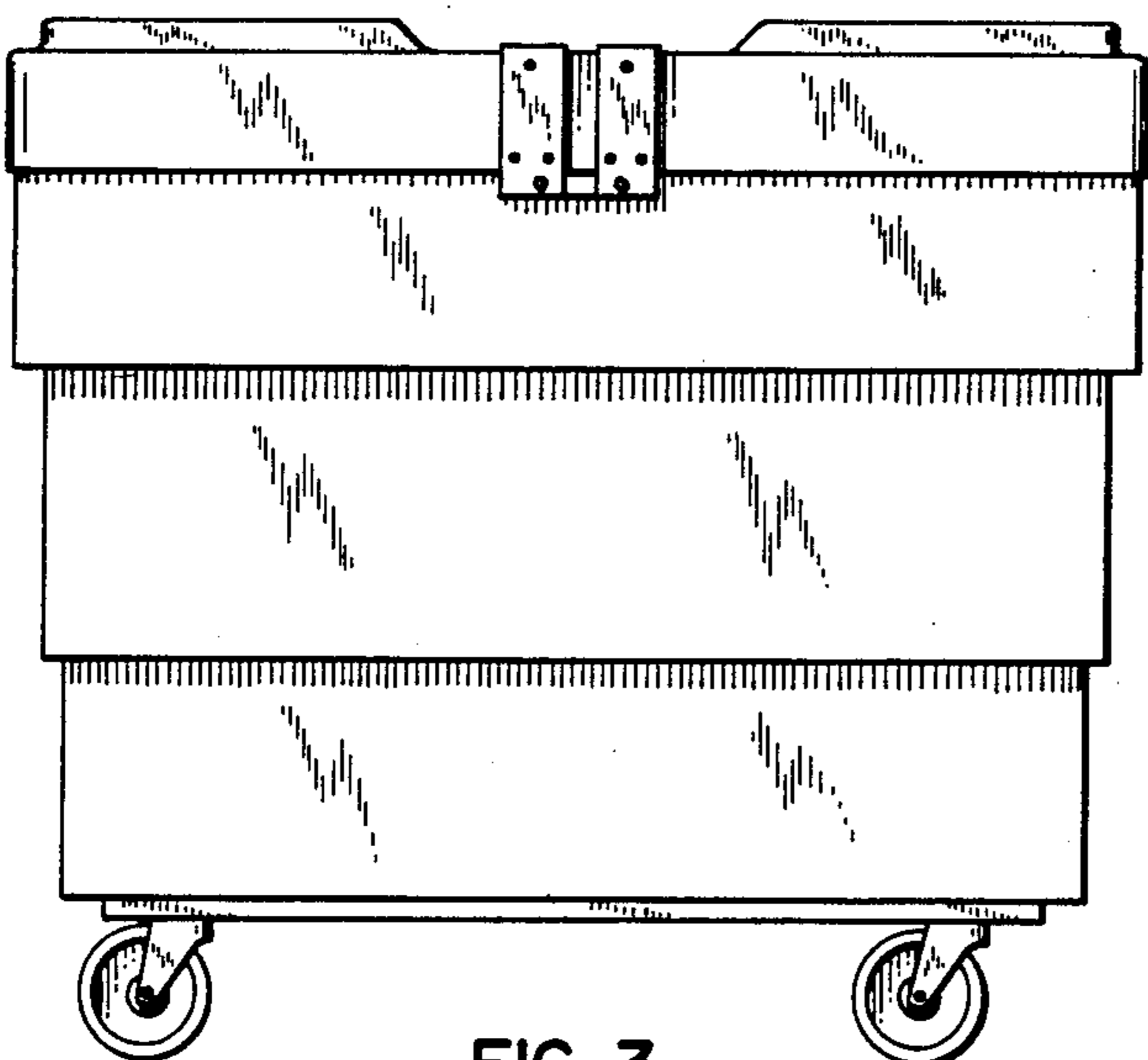

FIG. 3

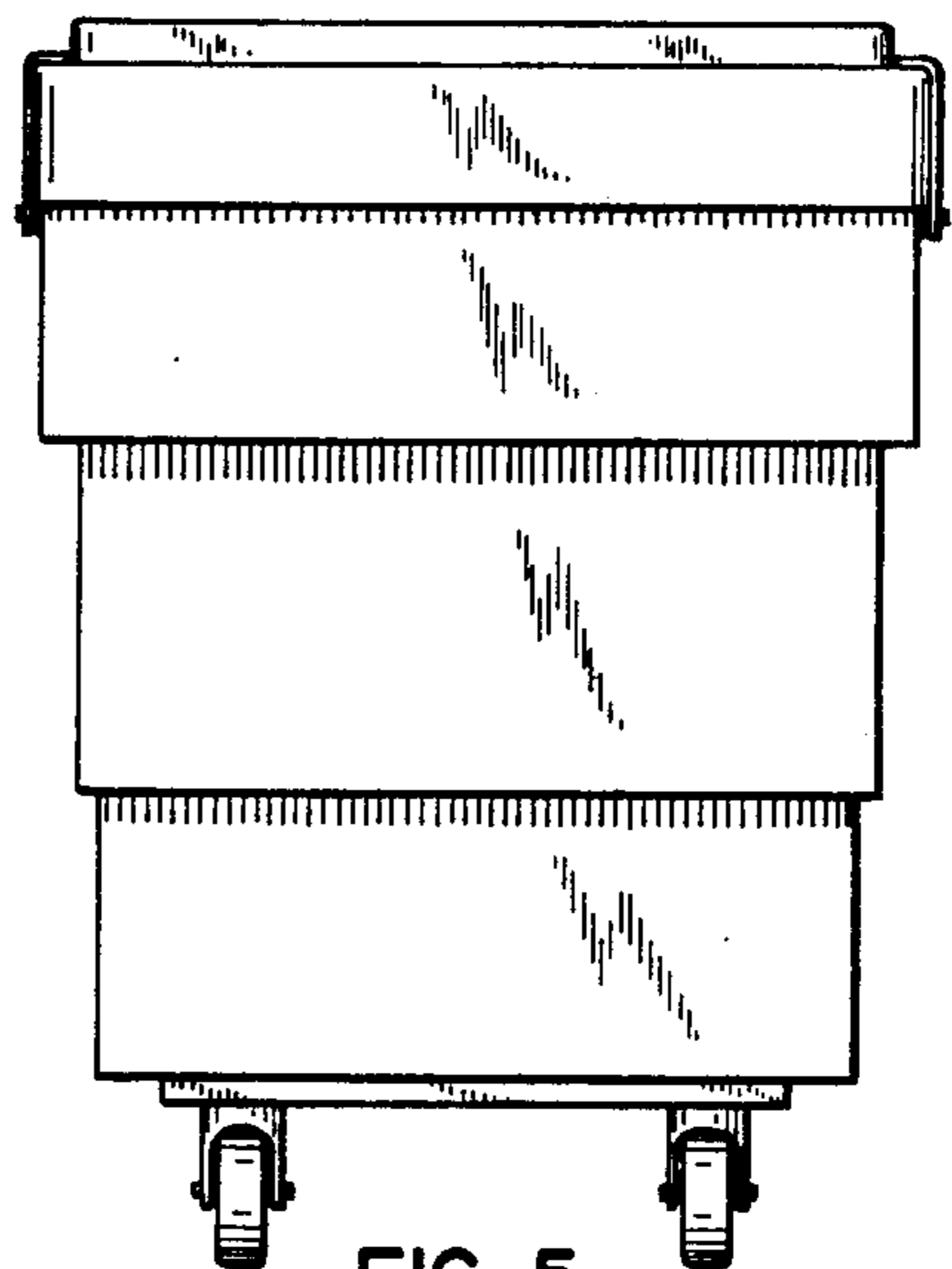

FIG. 5

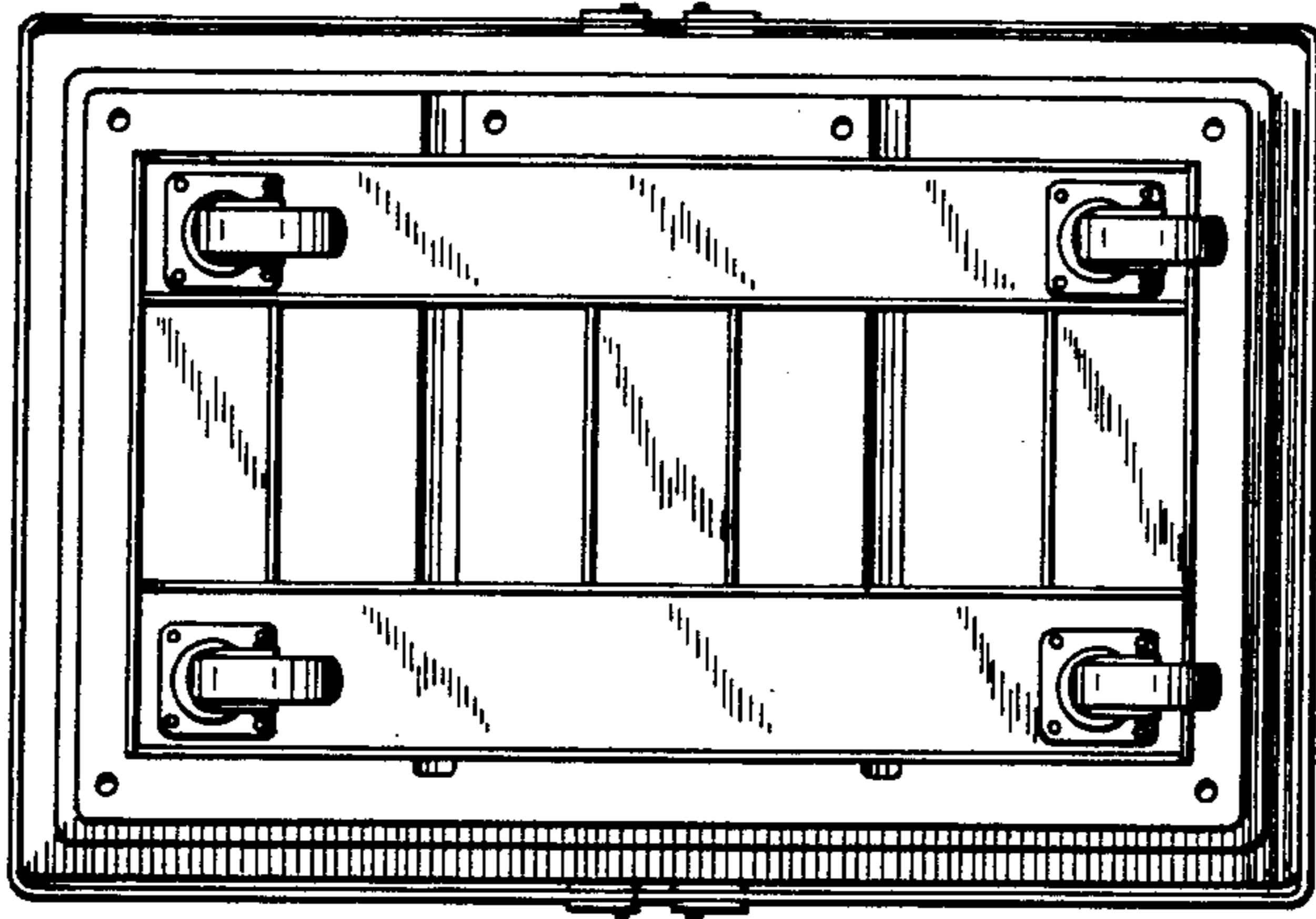

FIG. 6

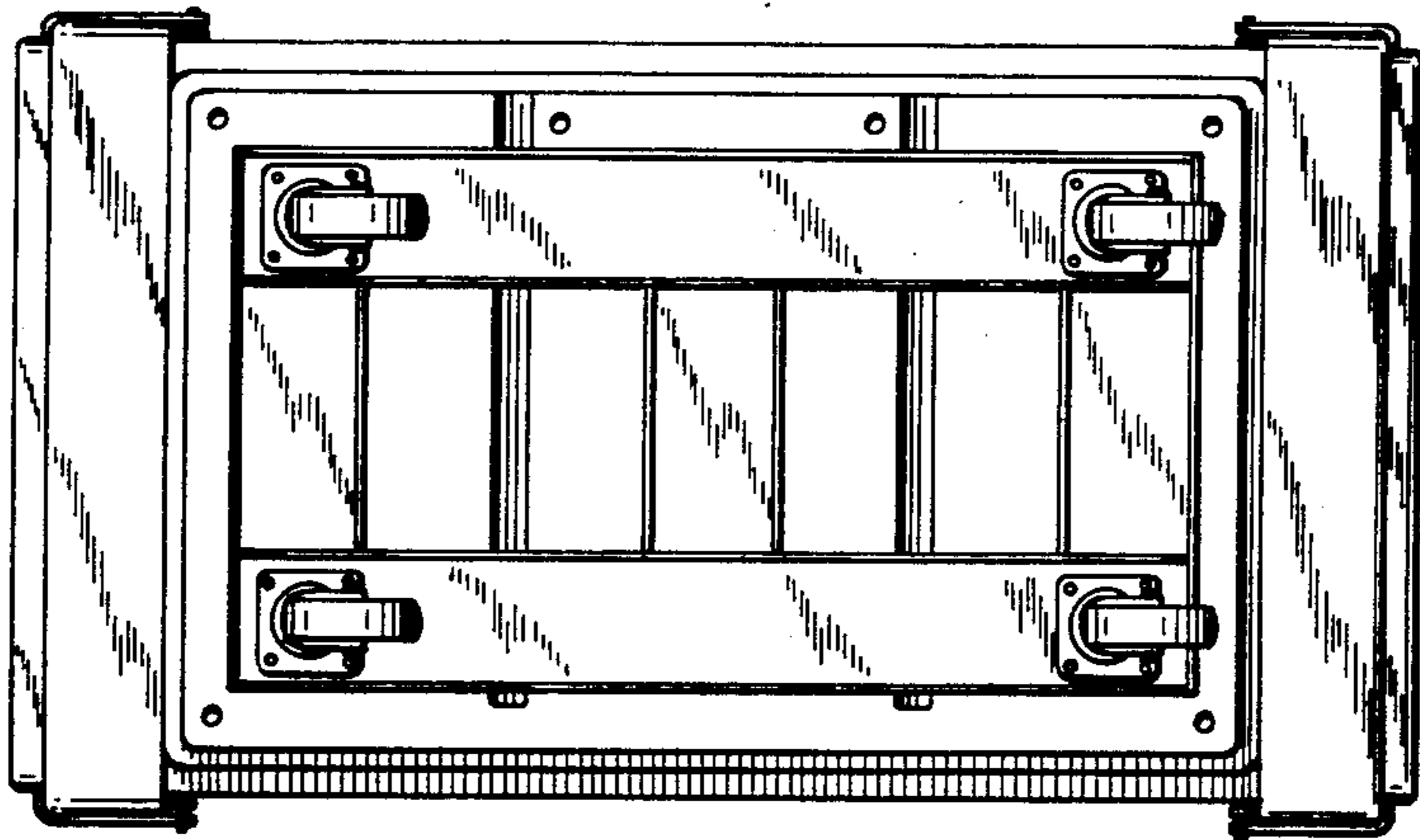

FIG. 12

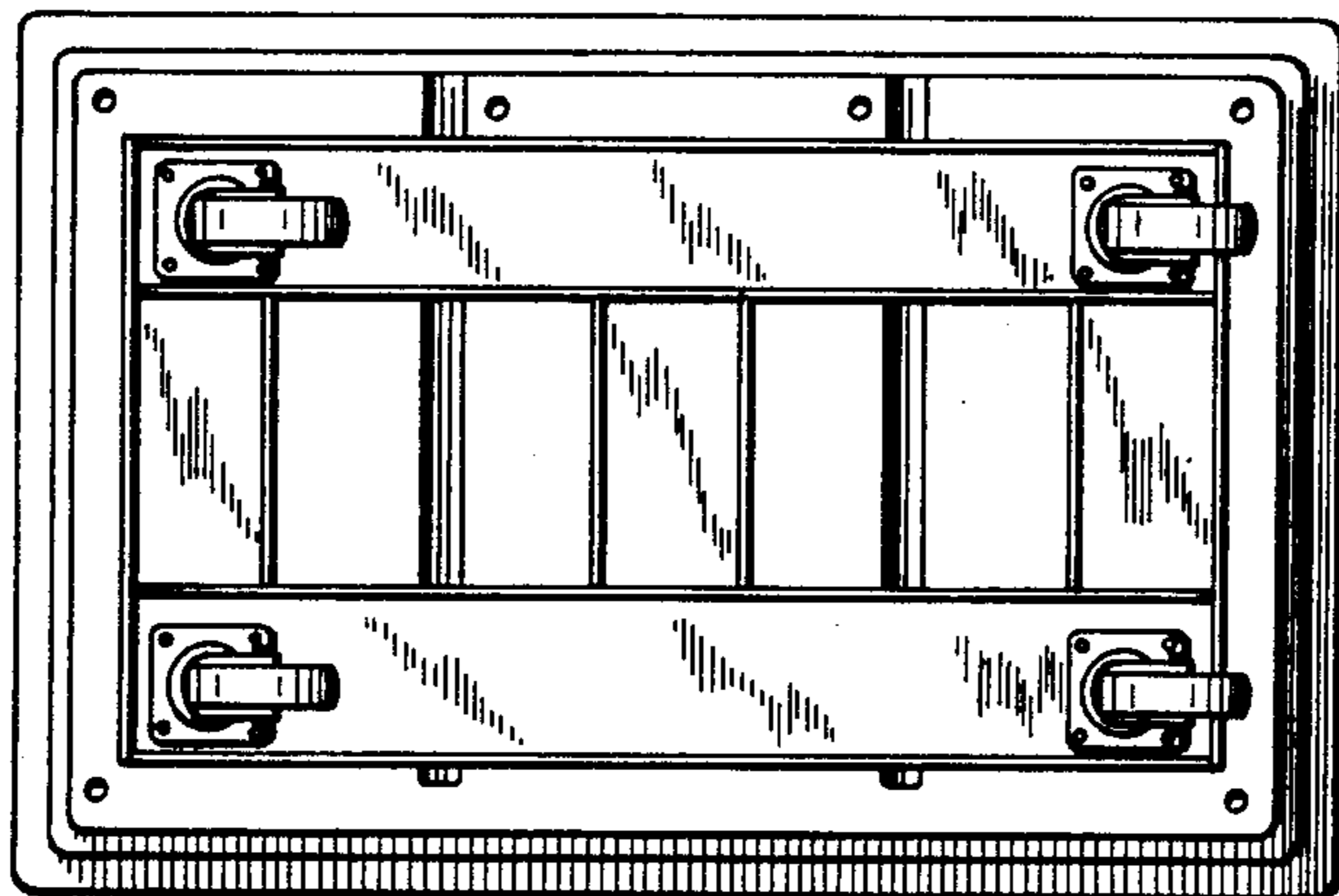

FIG. 18

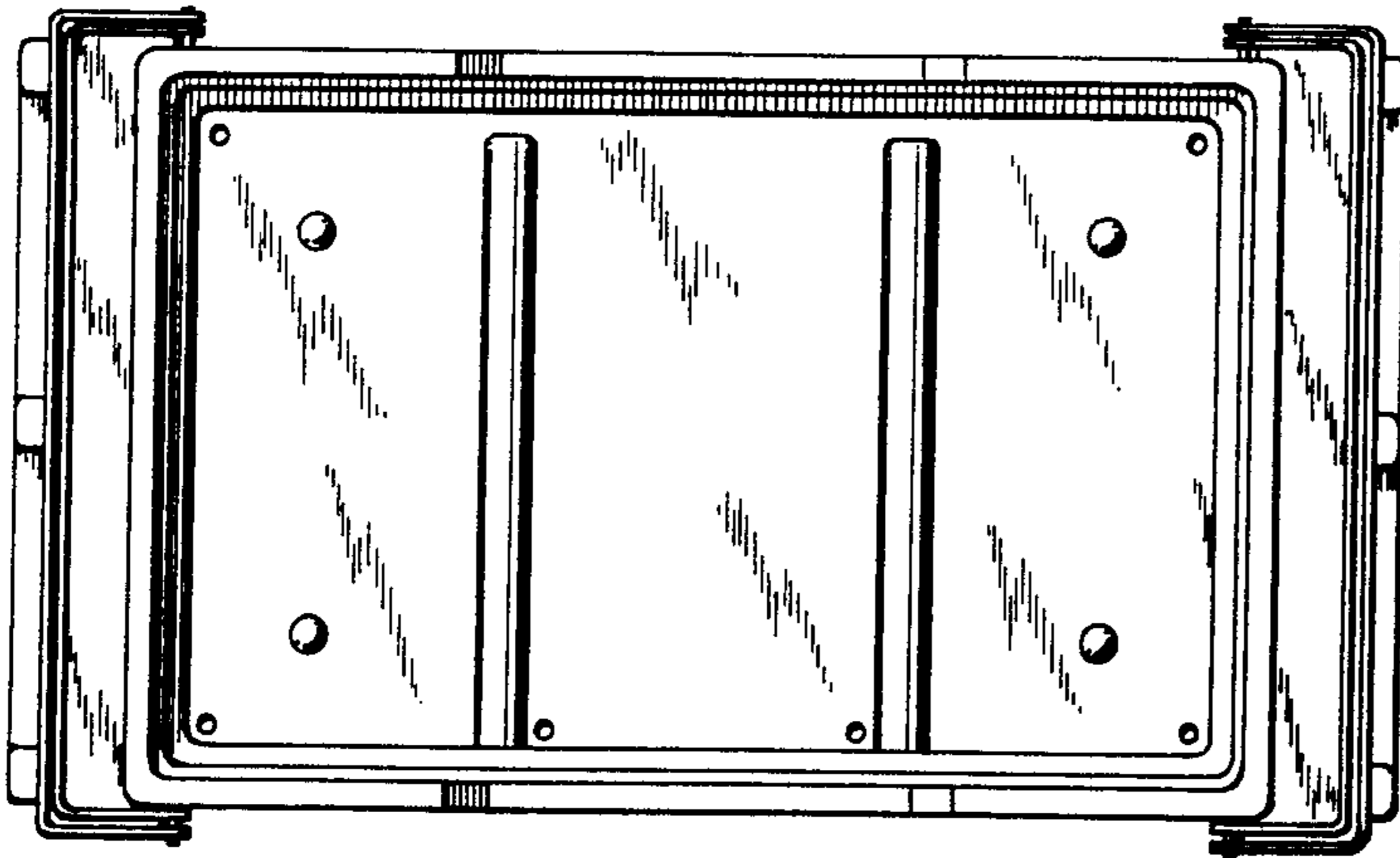

FIG. 7

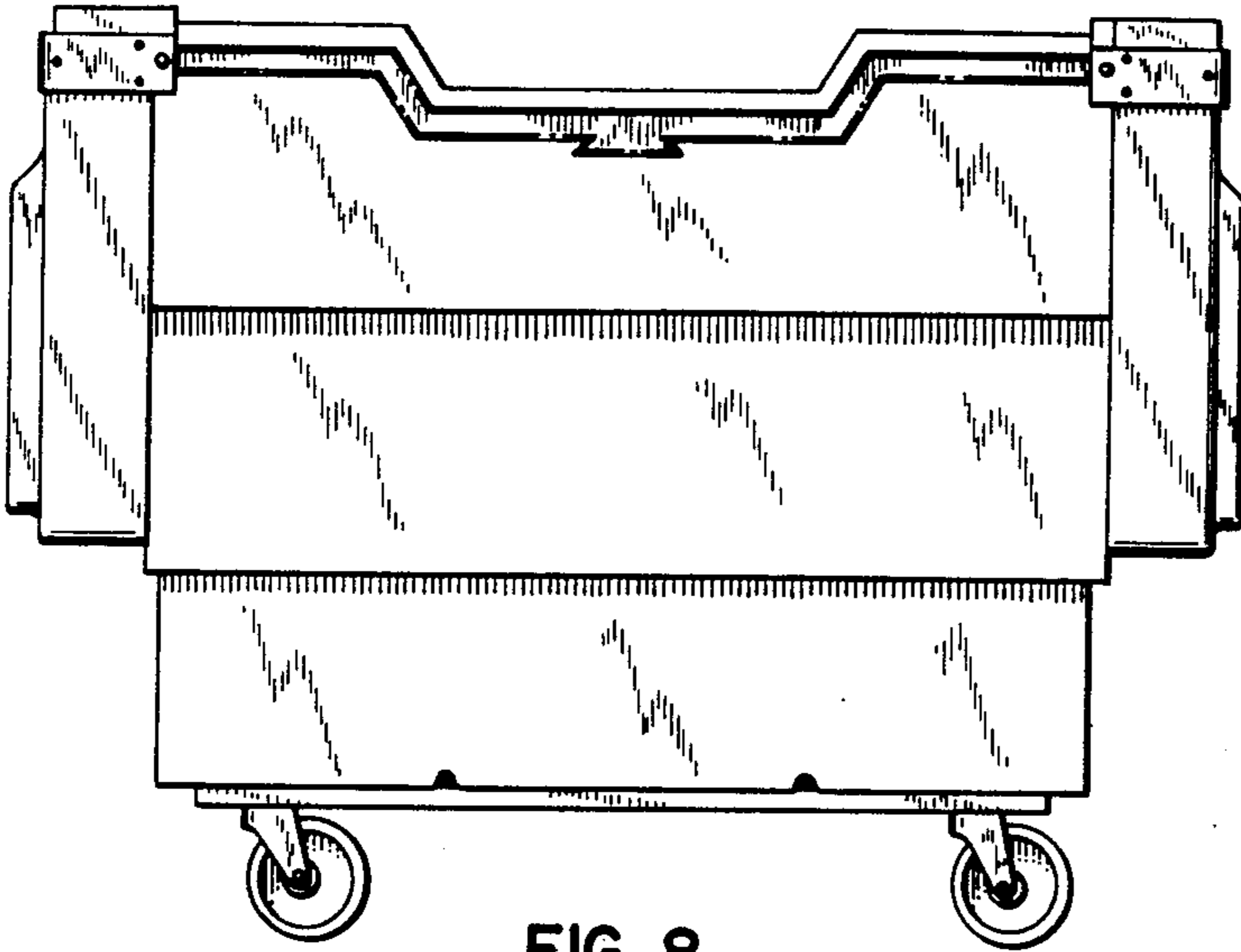

FIG. 8

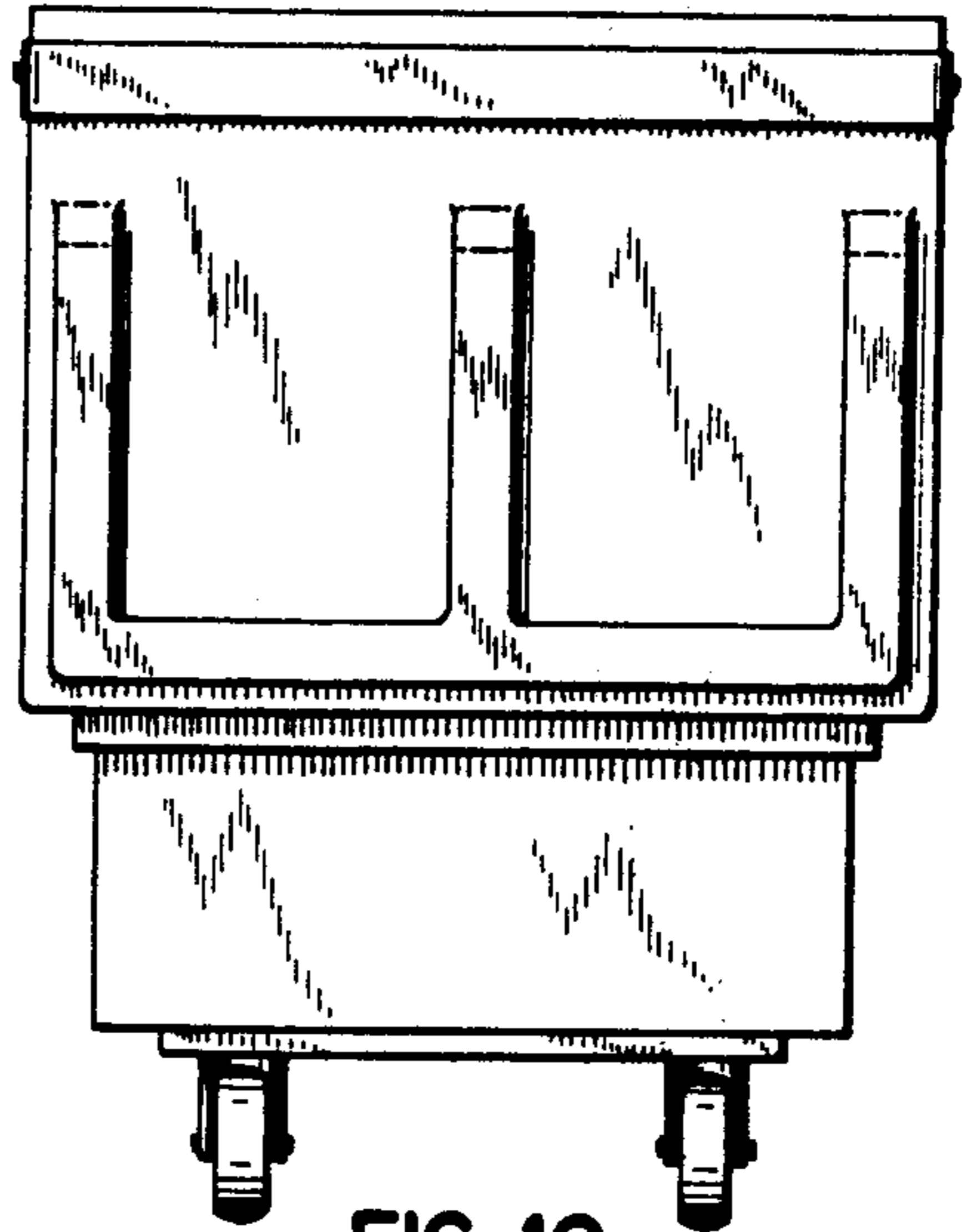

FIG. 10

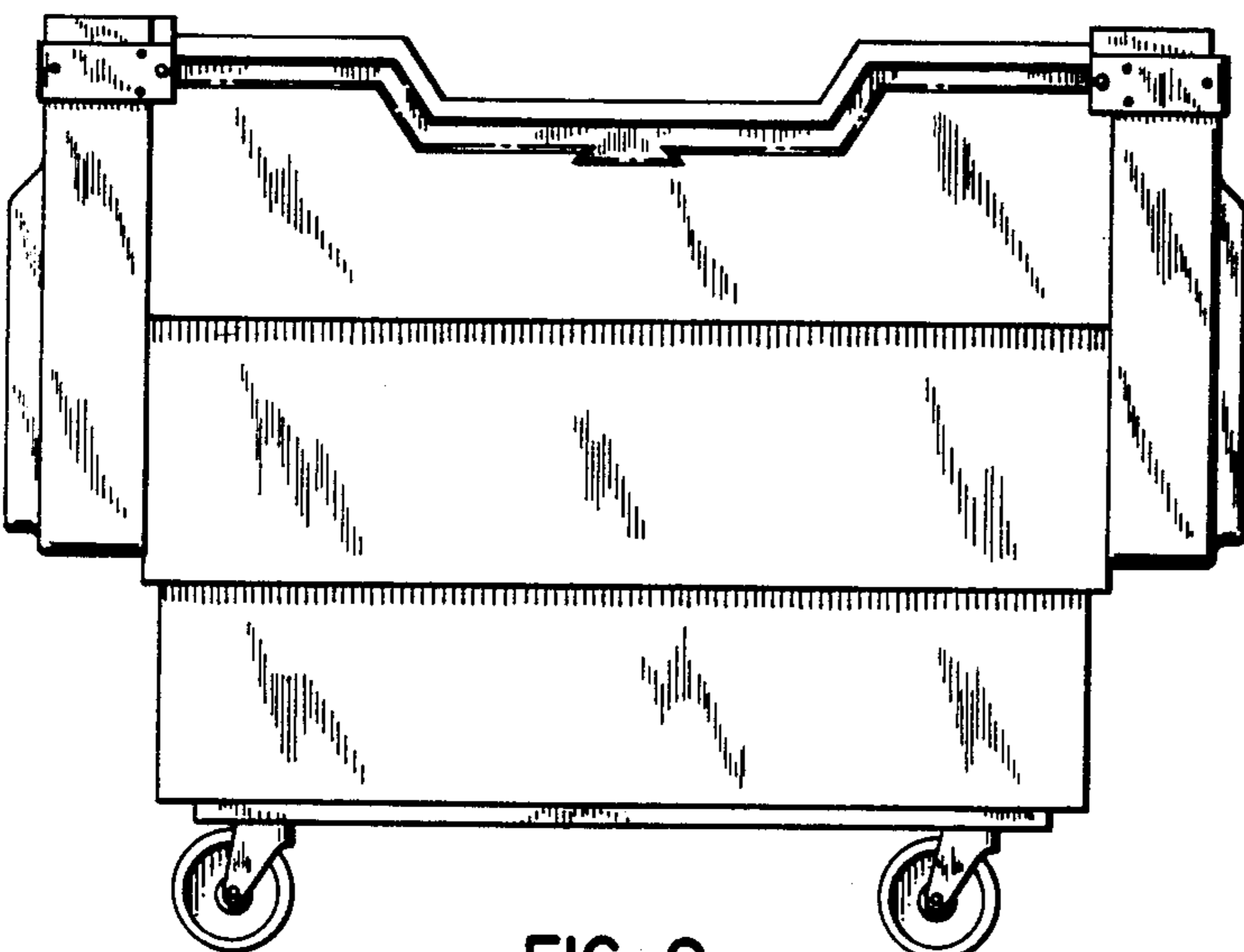

FIG. 9

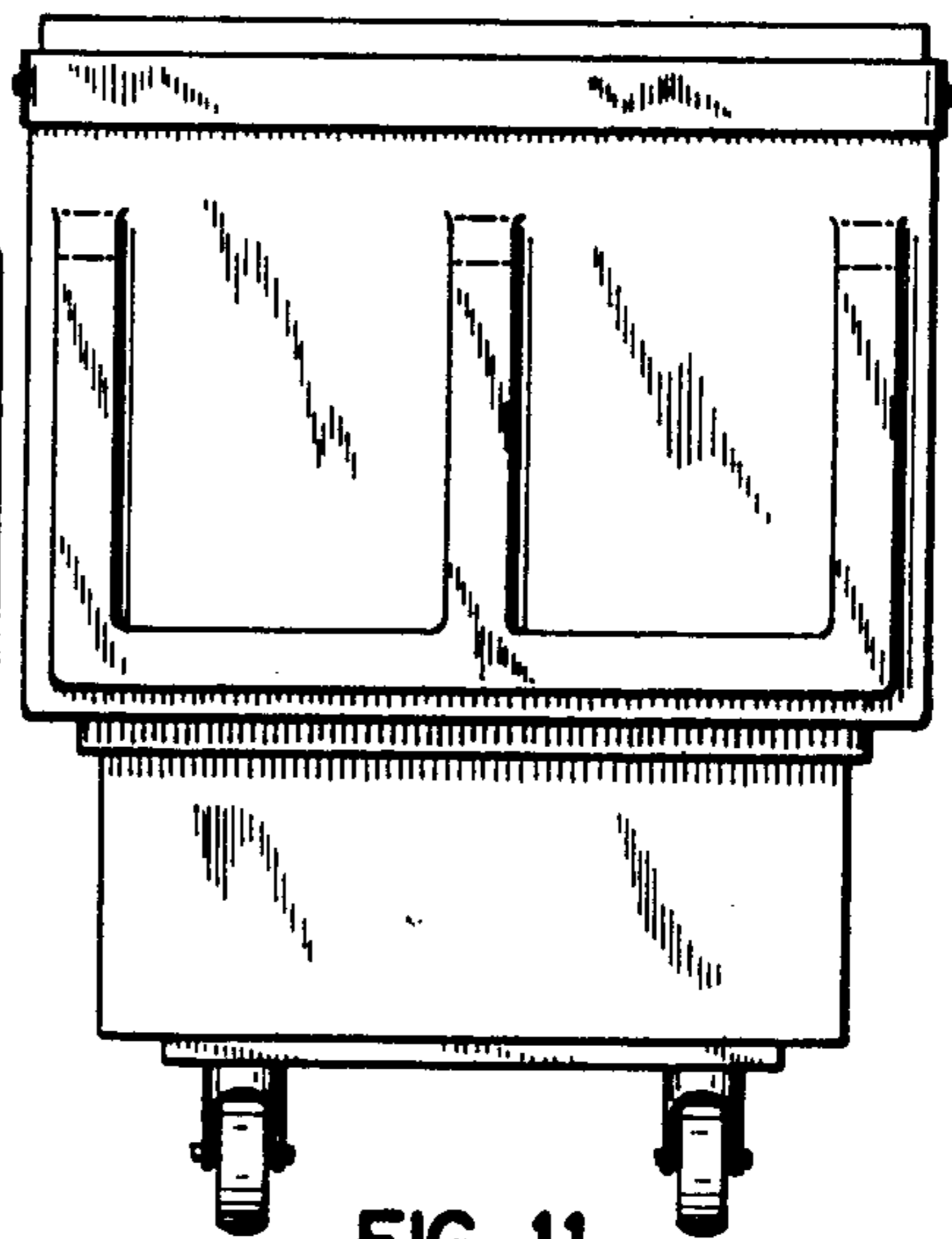

FIG. 11

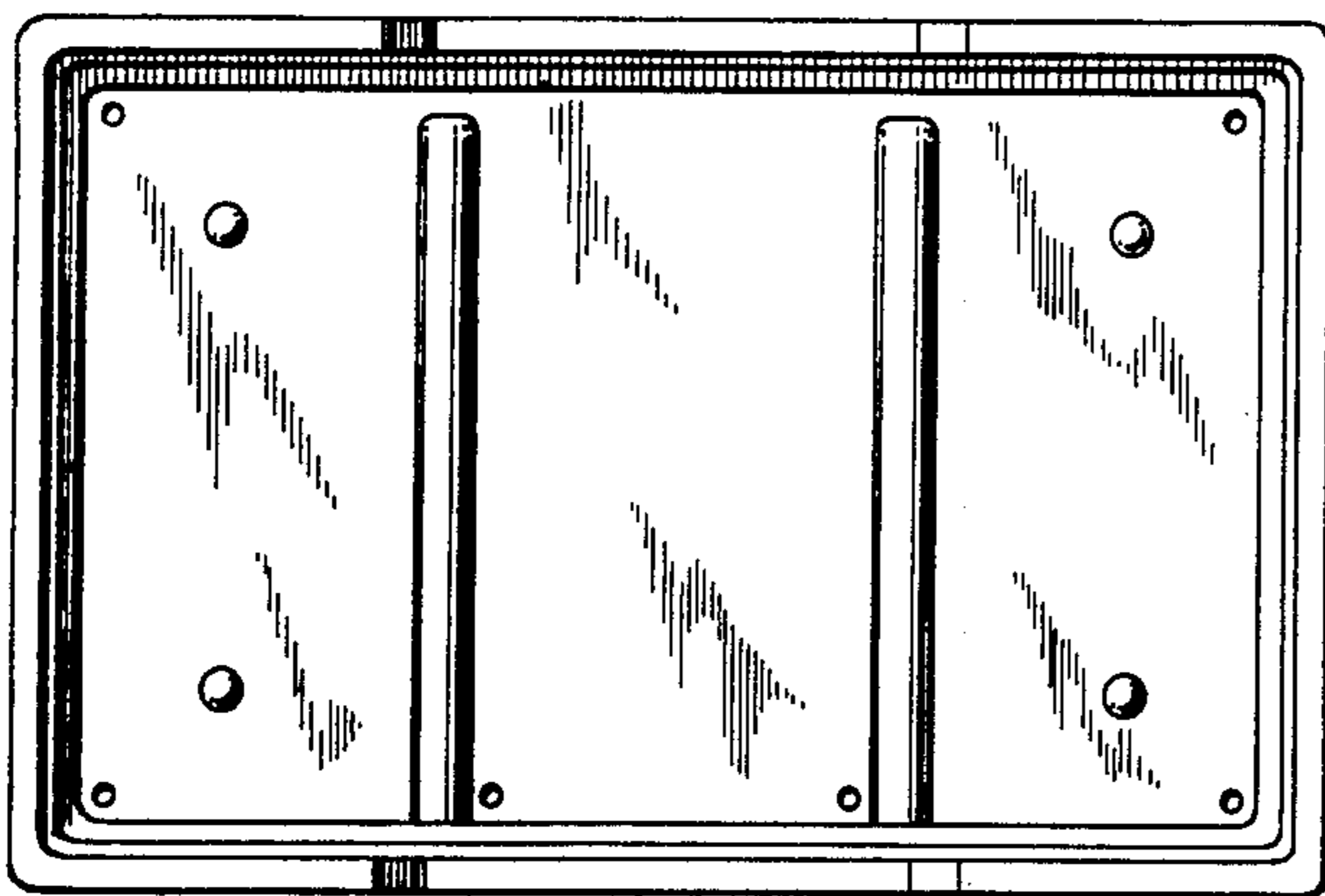

FIG. 13

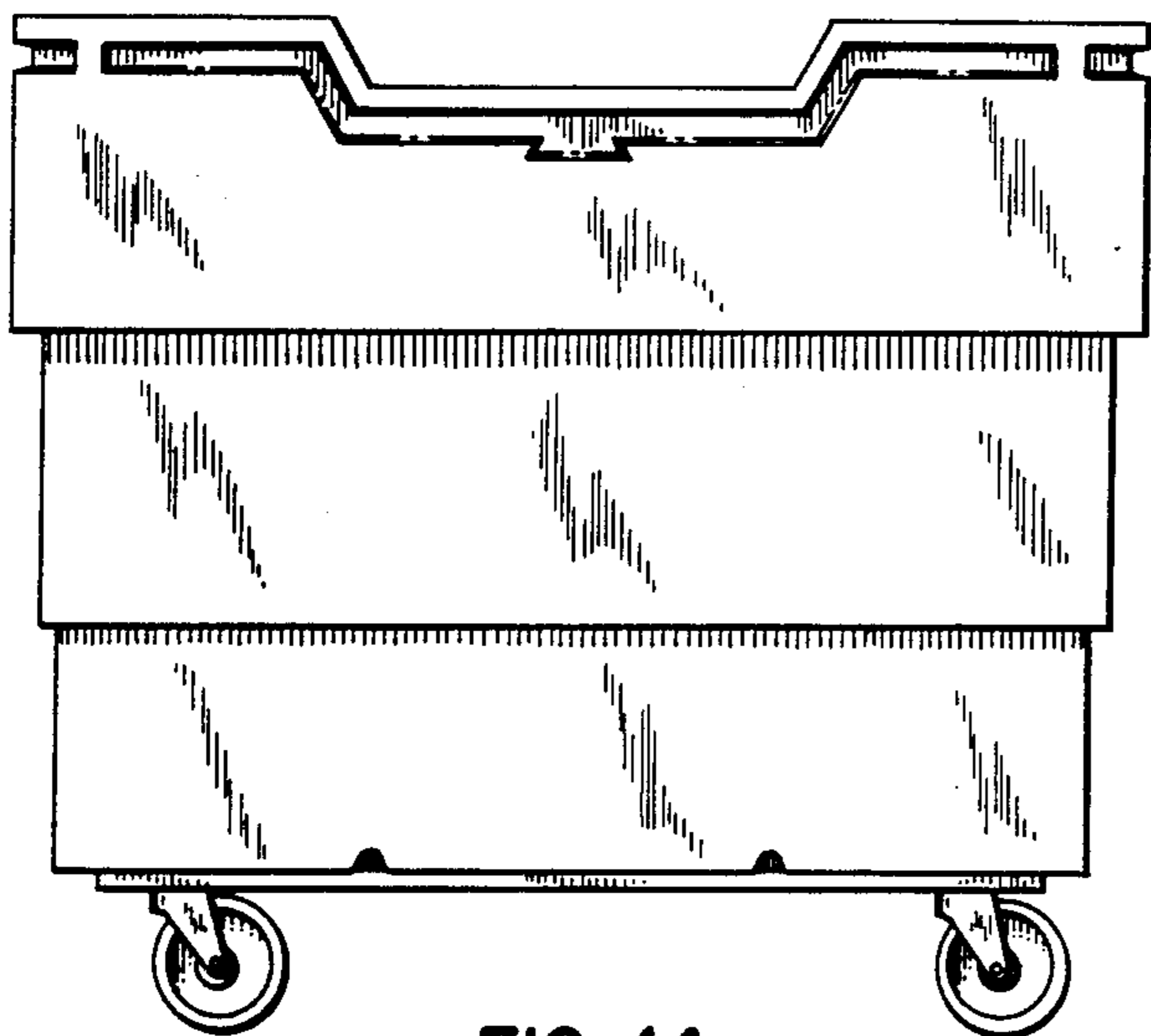

FIG. 14

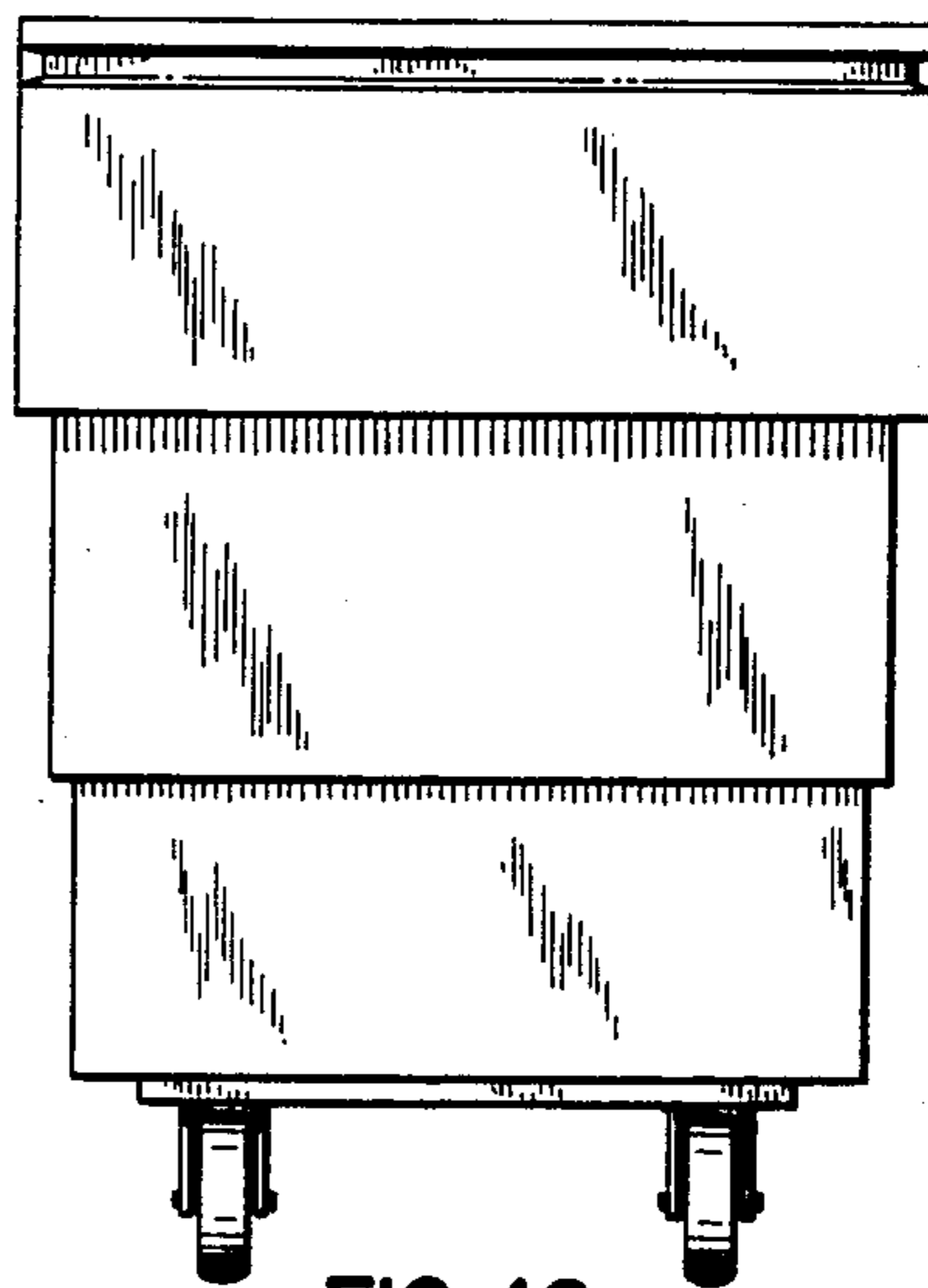

FIG. 16

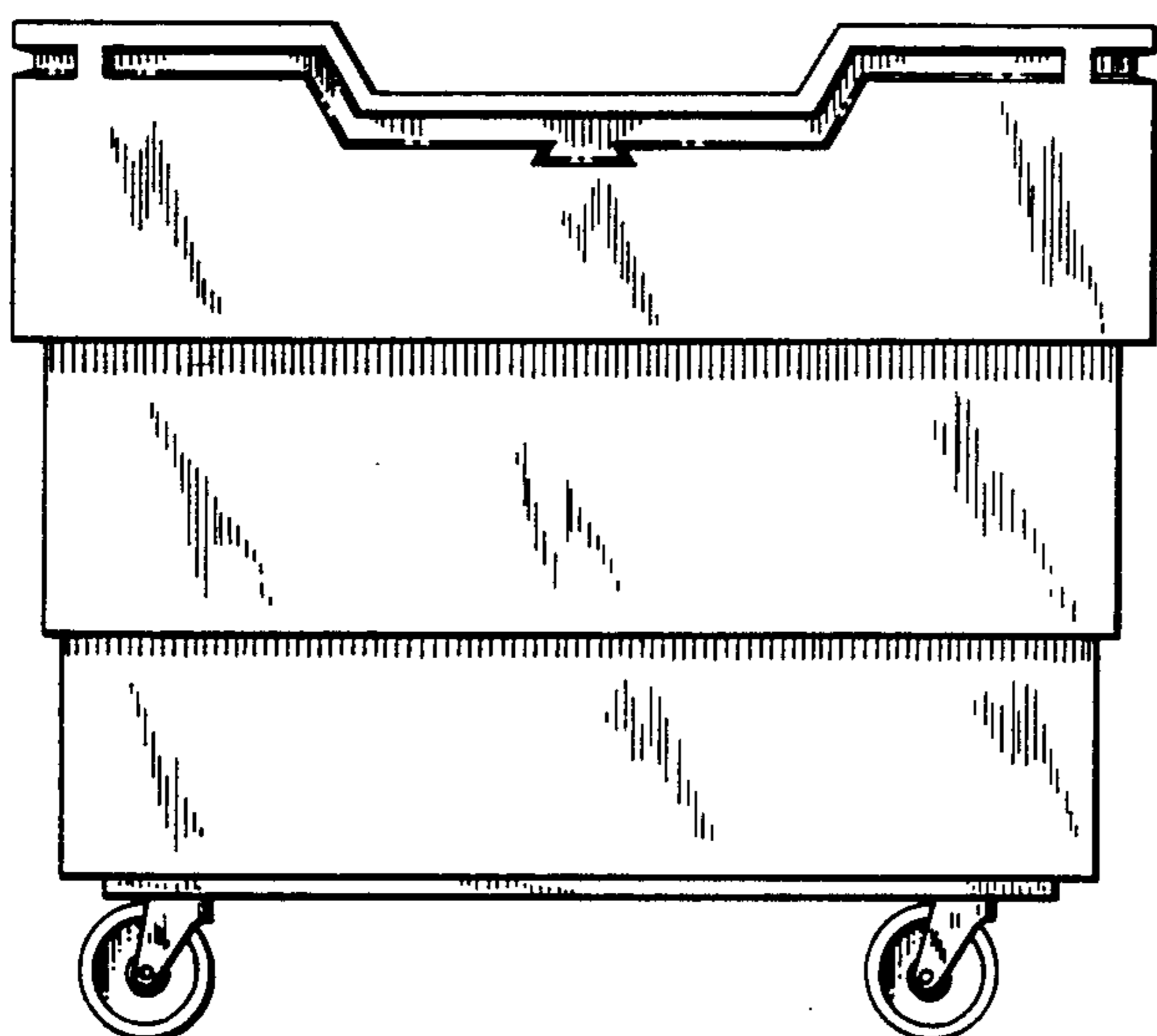

FIG. 15

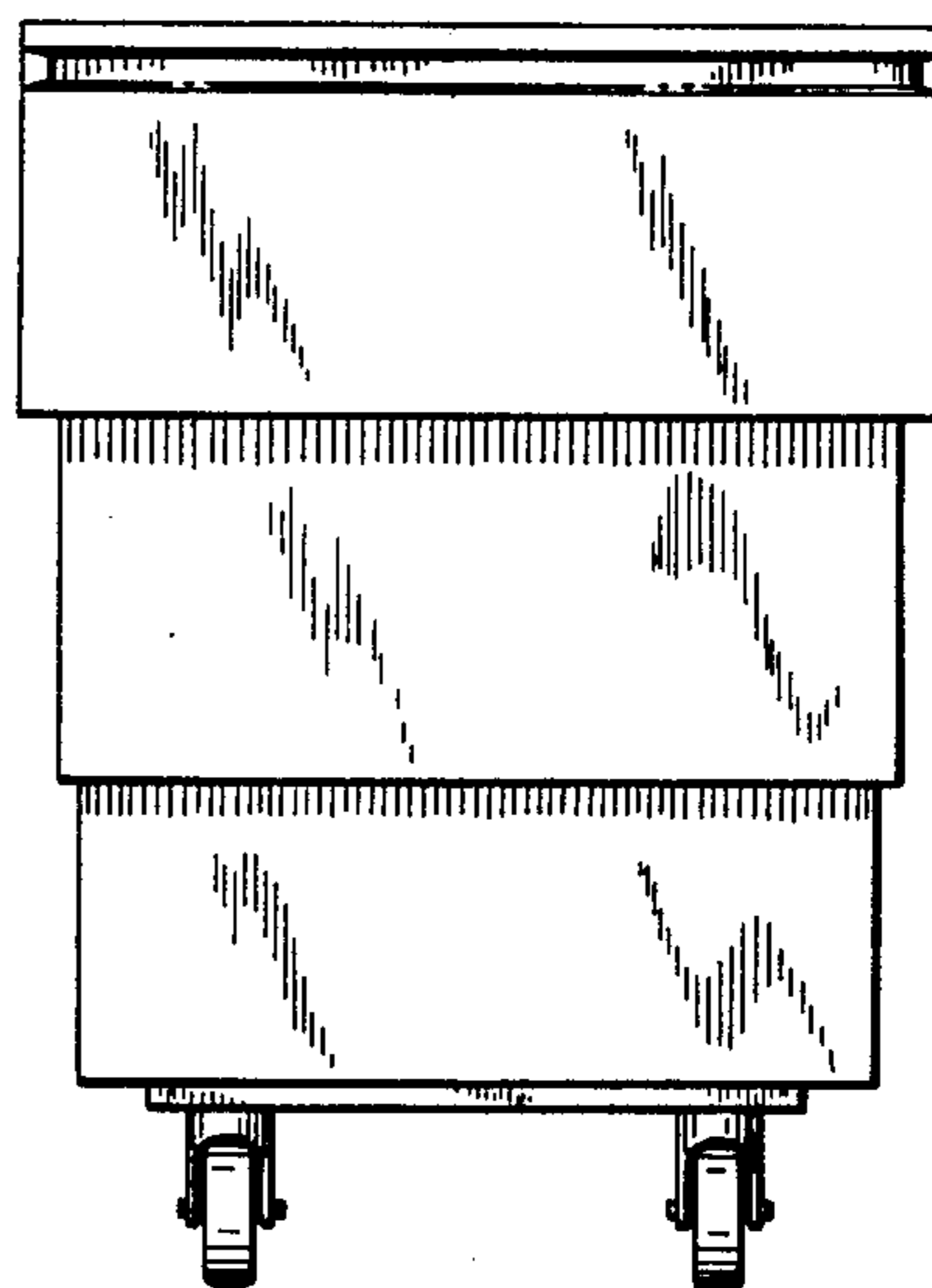

FIG. 17