

[54] HANDLEBAR STEM

[76] Inventors: Craig A. Cook, 4810 Park Newport, #313, Newport Beach, Calif. 92627; Gary B. Cook, 26871 Avenida Domingo, Mission Viejo, Calif. 92675

[**] Term: 14 Years

[21] Appl. No.: 876,585

[22] Filed: Feb. 10, 1978

[51] Int. Cl. D12-11

[52] U.S. Cl. D12/118

[58] Field of Search D12/117, 118; 403/373, 403/374, 376; 280/280, 279, 289 R

[56] References Cited

PUBLICATIONS

American Bicyclist & Motorcyclist, p. 38, 1/77, Chromemoly MX Stem, bottom center of page.

Primary Examiner—James M. Gandy
Attorney, Agent, or Firm—Louis J. Knobbe

[57] CLAIM

The ornamental design for a handlebar stem, as shown.

DESCRIPTION

FIG. 1 is a front elevational view of a handlebar stem showing our new design;

FIG. 2 is a right side elevational view thereof;

FIG. 3 is a left side elevational view thereof;

FIG. 4 is a top plan view thereof;

FIG. 5 is a bottom plan view thereof; and

FIG. 6 is a rear elevational view thereof.

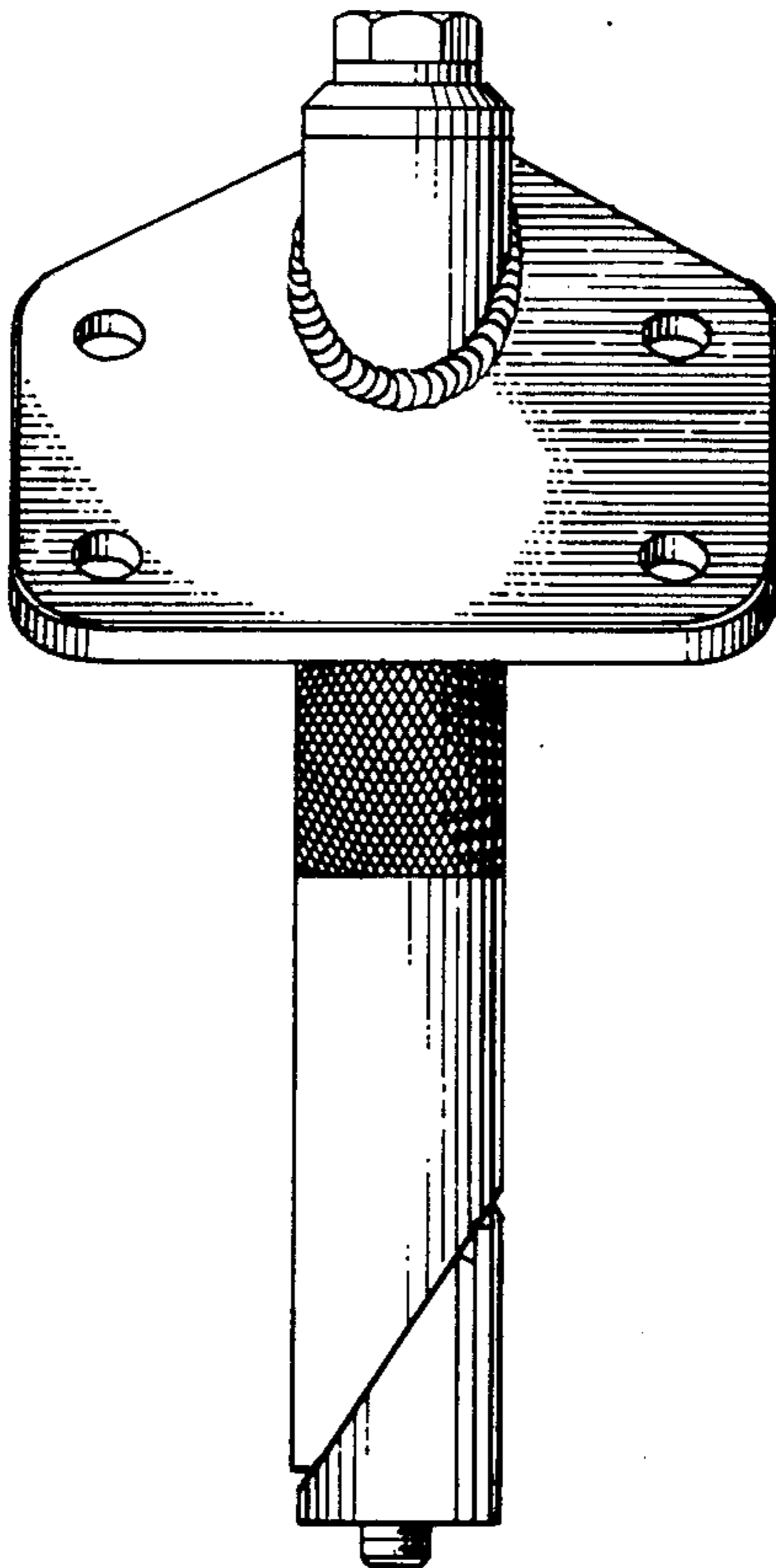

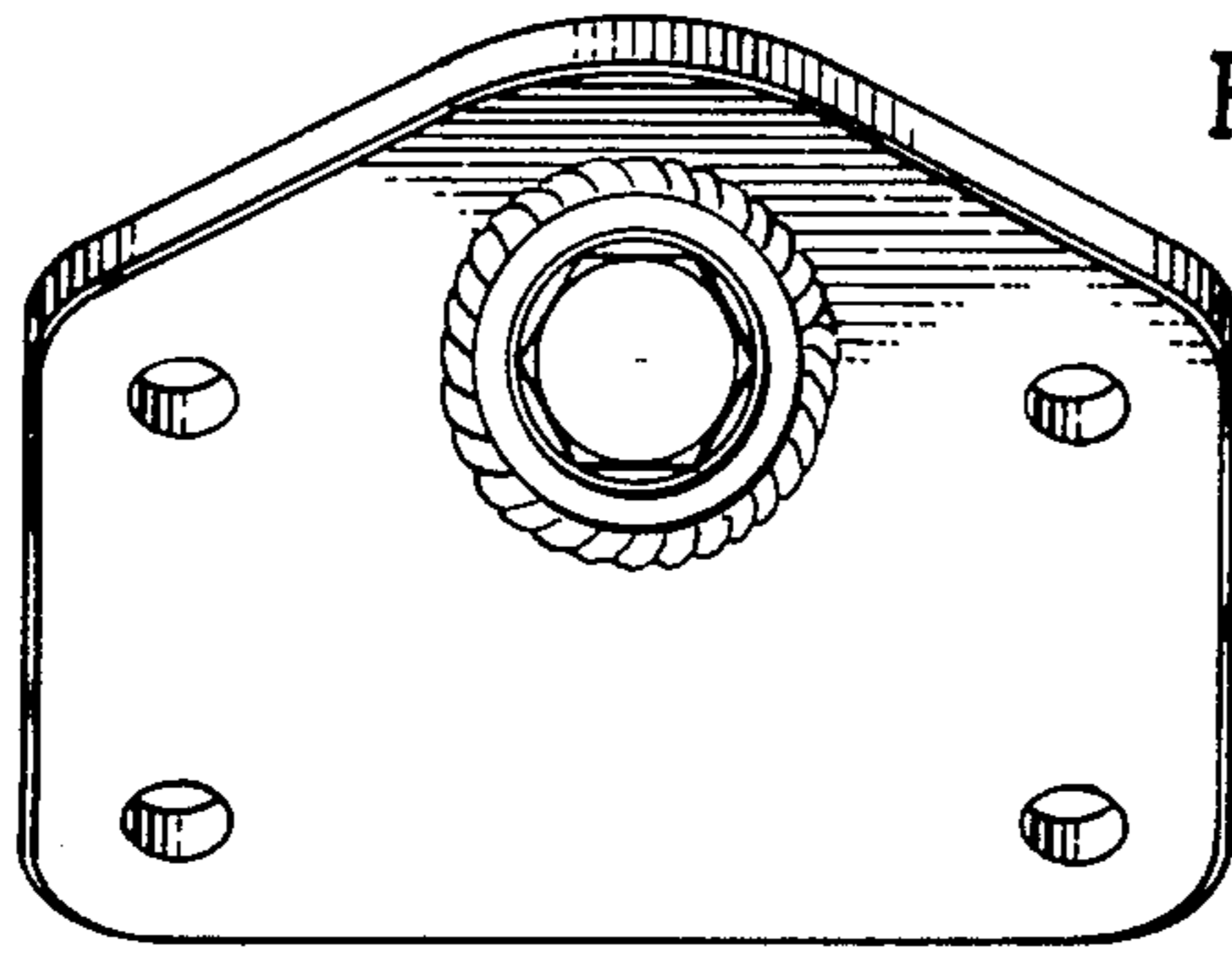

FIG. 4.

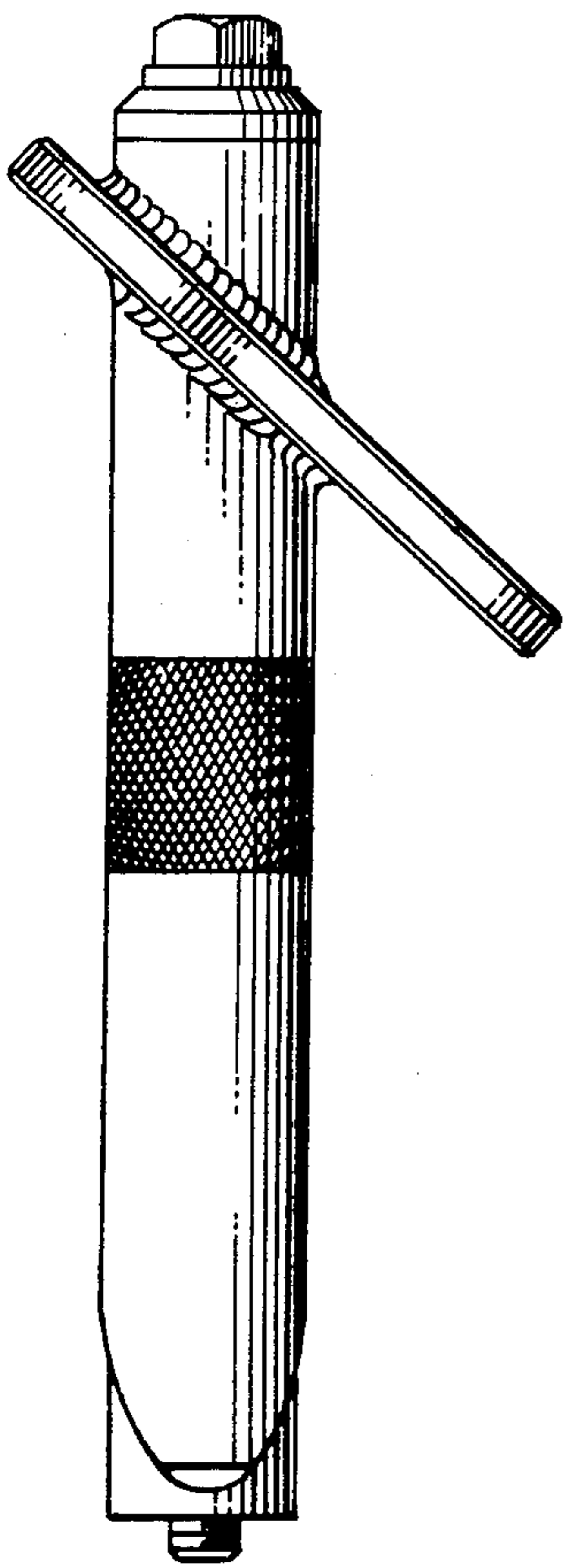

FIG. 3.

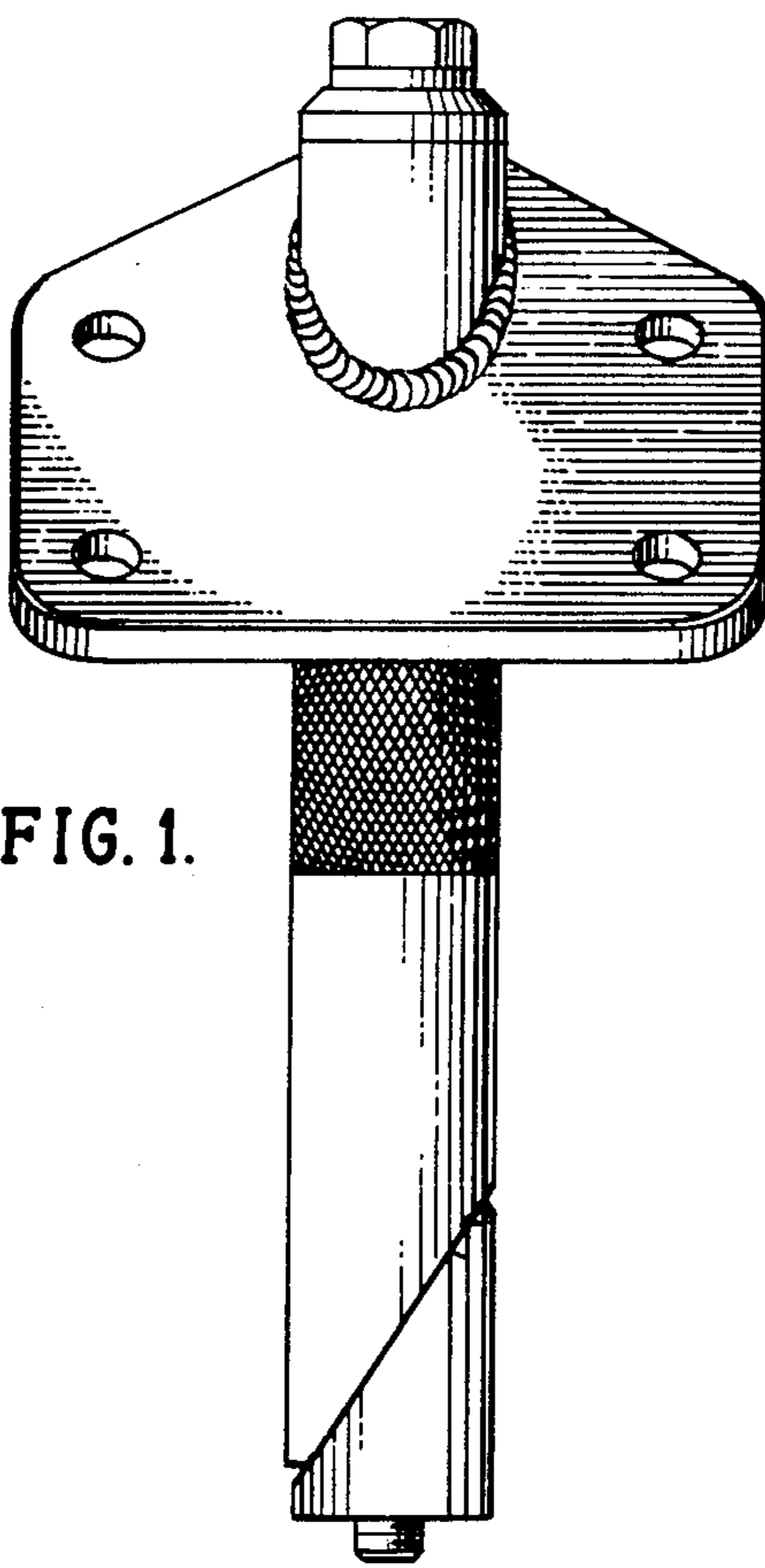

FIG. 1.

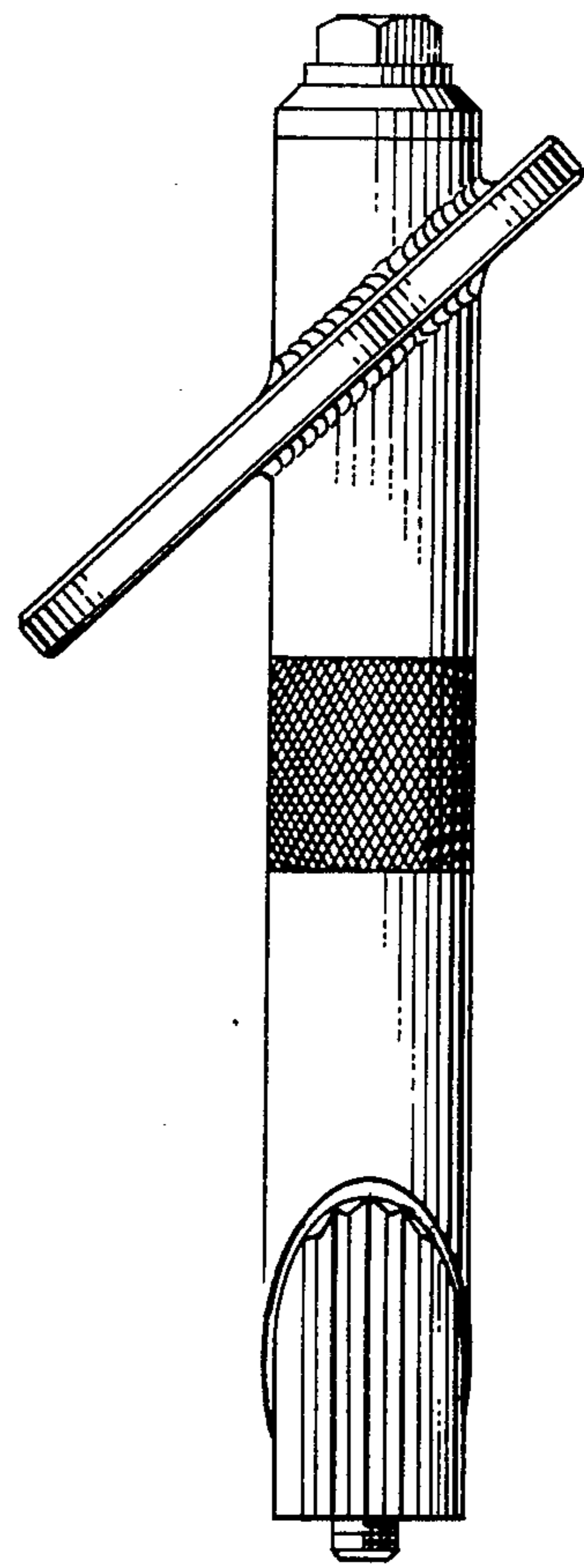

FIG. 2.

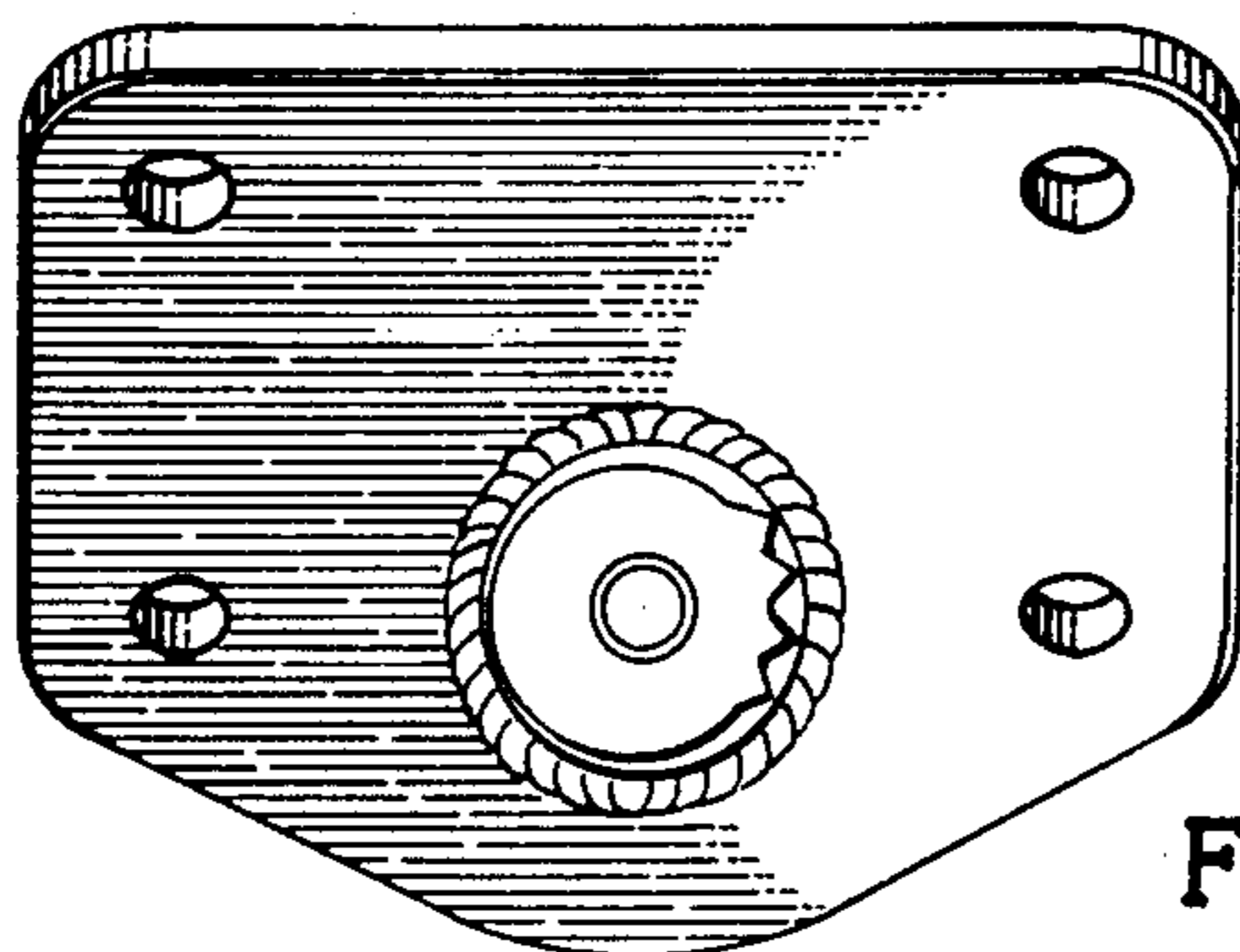

FIG. 5.

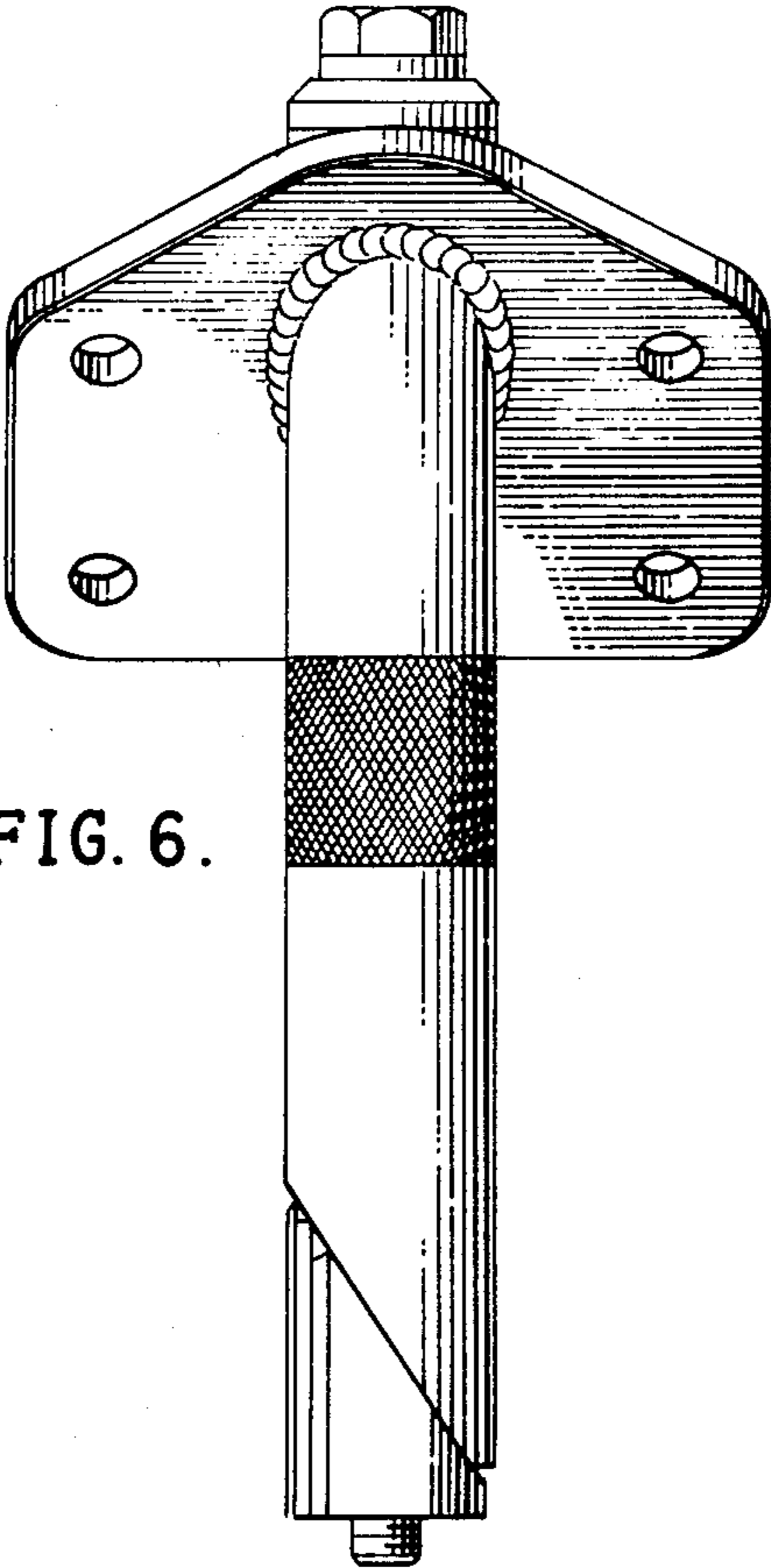

FIG. 6.