

[54] PROPELLER DRIVEN TOY VEHICLE

[76] Inventors: Adolph E. Goldfarb, 4614 Monarca Dr., Tarzana, Calif. 91345; Erwin Benkoe, deceased, late of Encino, Calif., by Elisabeth Benkoe, executrix, 17965 Medley Dr., Encino, Calif. 91316

[**] Term: 14 Years

[21] Appl. No.: 822,042

[22] Filed: Aug. 5, 1977

[51] Int. Cl. D21-01

[52] U.S. Cl. D21/76

[58] Field of Search D34/15 AJ, 15 AN, 15 MM; 46/113, 111, 97, 201, 202, 206, 210, 47, 78

[56] References Cited

U.S. PATENT DOCUMENTS

D. 220,276 3/1971 Gurney D34/15 AJ
3,878,642 4/1975 Lemelson 46/206

OTHER PUBLICATIONS

Popular Mechanics, 5-1938, p. 719, propeller driven vehicle.

Primary Examiner—Joel Stearman
Assistant Examiner—Charles A. Rademaker
Attorney, Agent, or Firm—Robert M. Ashen

[57] CLAIM

The ornamental design for a propeller driven toy vehicle, as shown.

DESCRIPTION

FIG. 1 is a top plan view of a propeller driven toy vehicle showing our new design; FIG. 2 is a side elevational view thereof; FIG. 3 is a bottom plan view thereof; FIG. 4 is a front elevational view thereof; and FIG. 5 is a rear elevational view thereof.

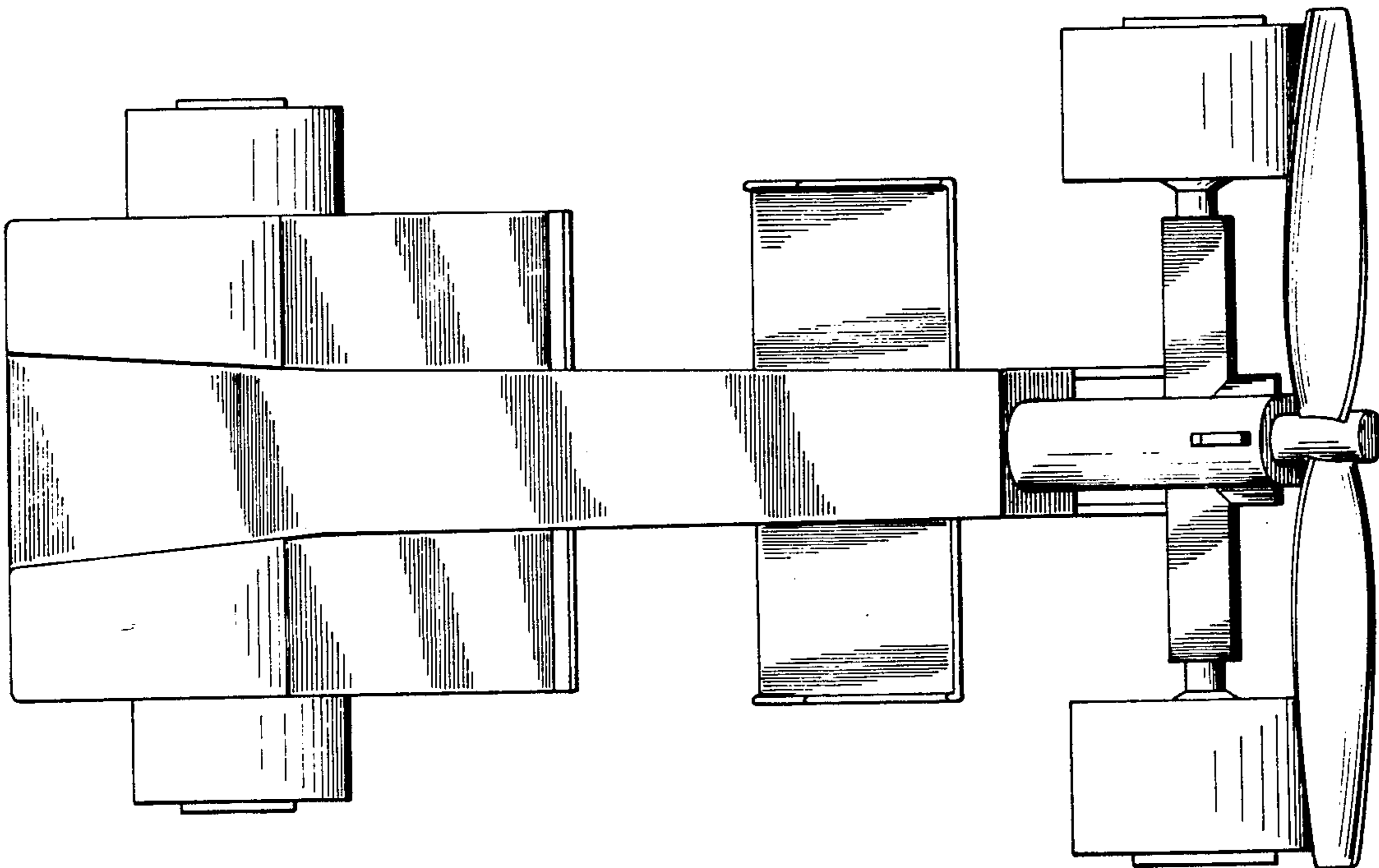

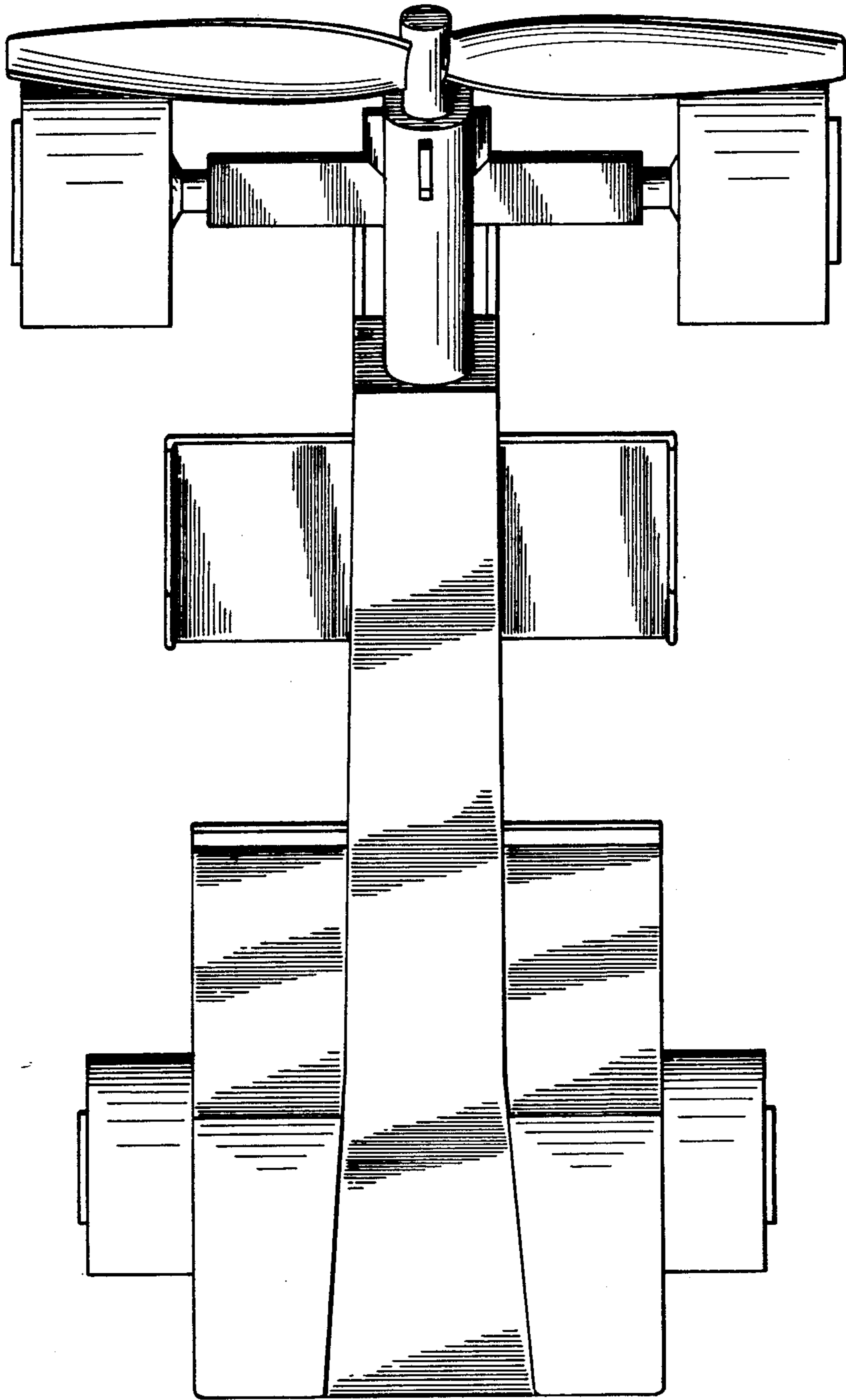

FIG. 1

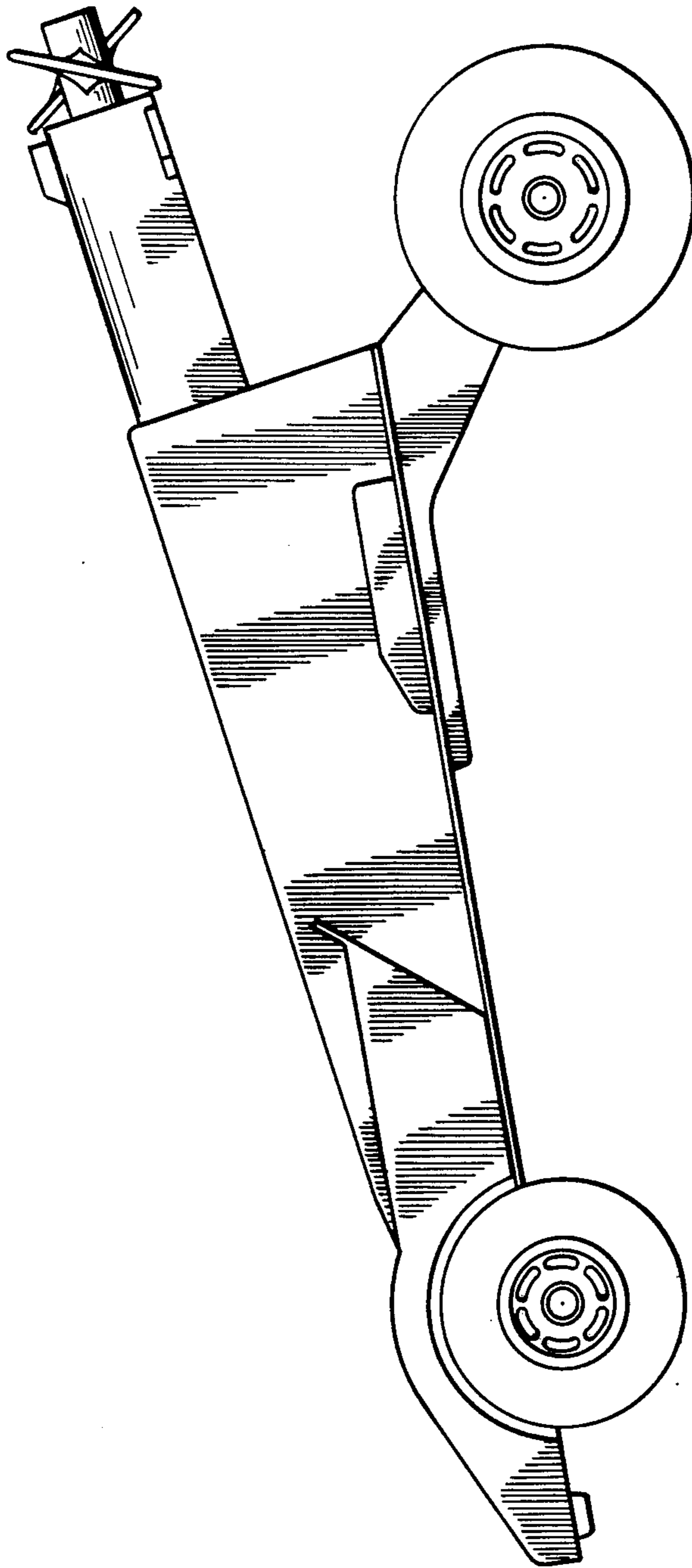

FIG. 2

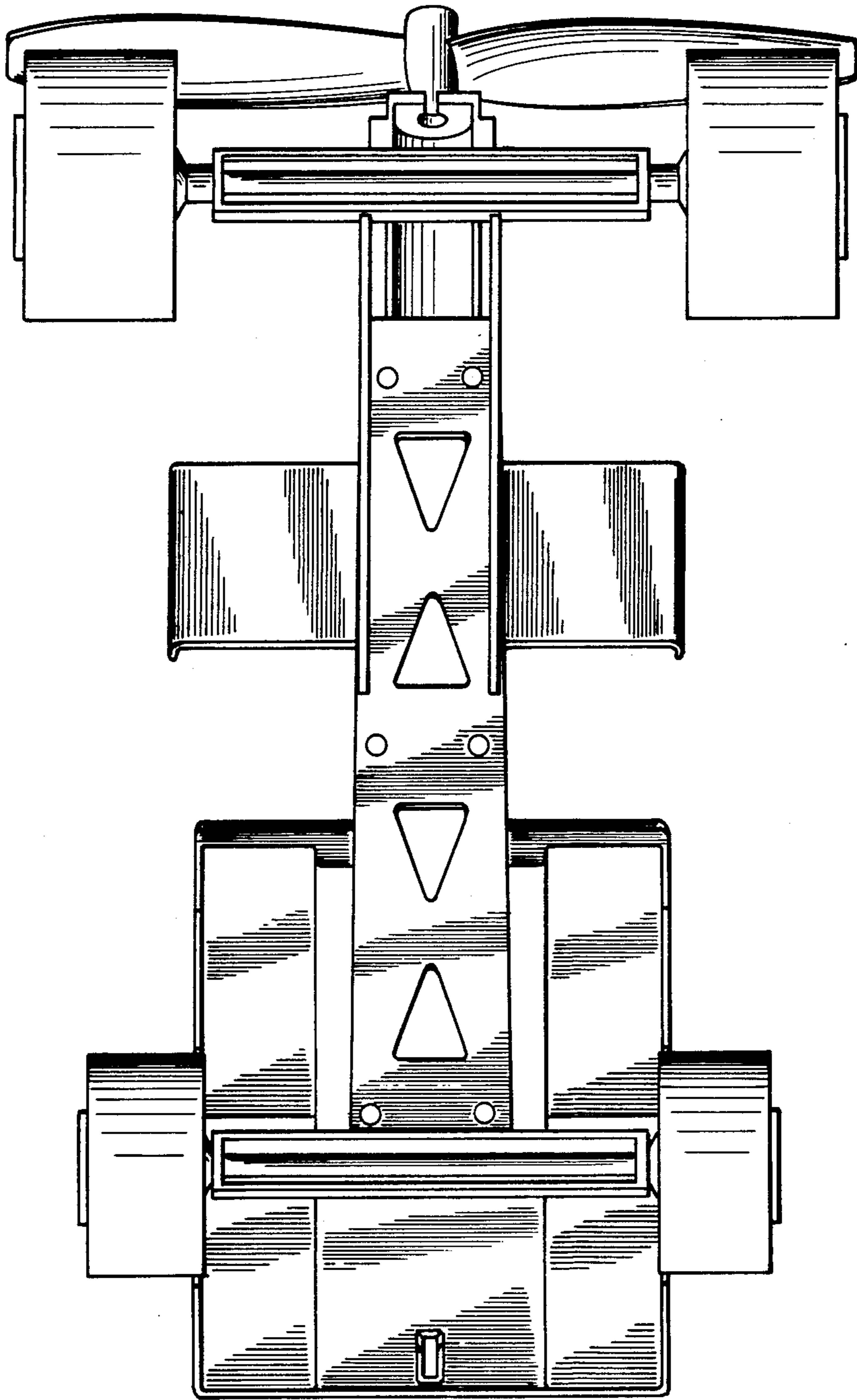

FIG. 3

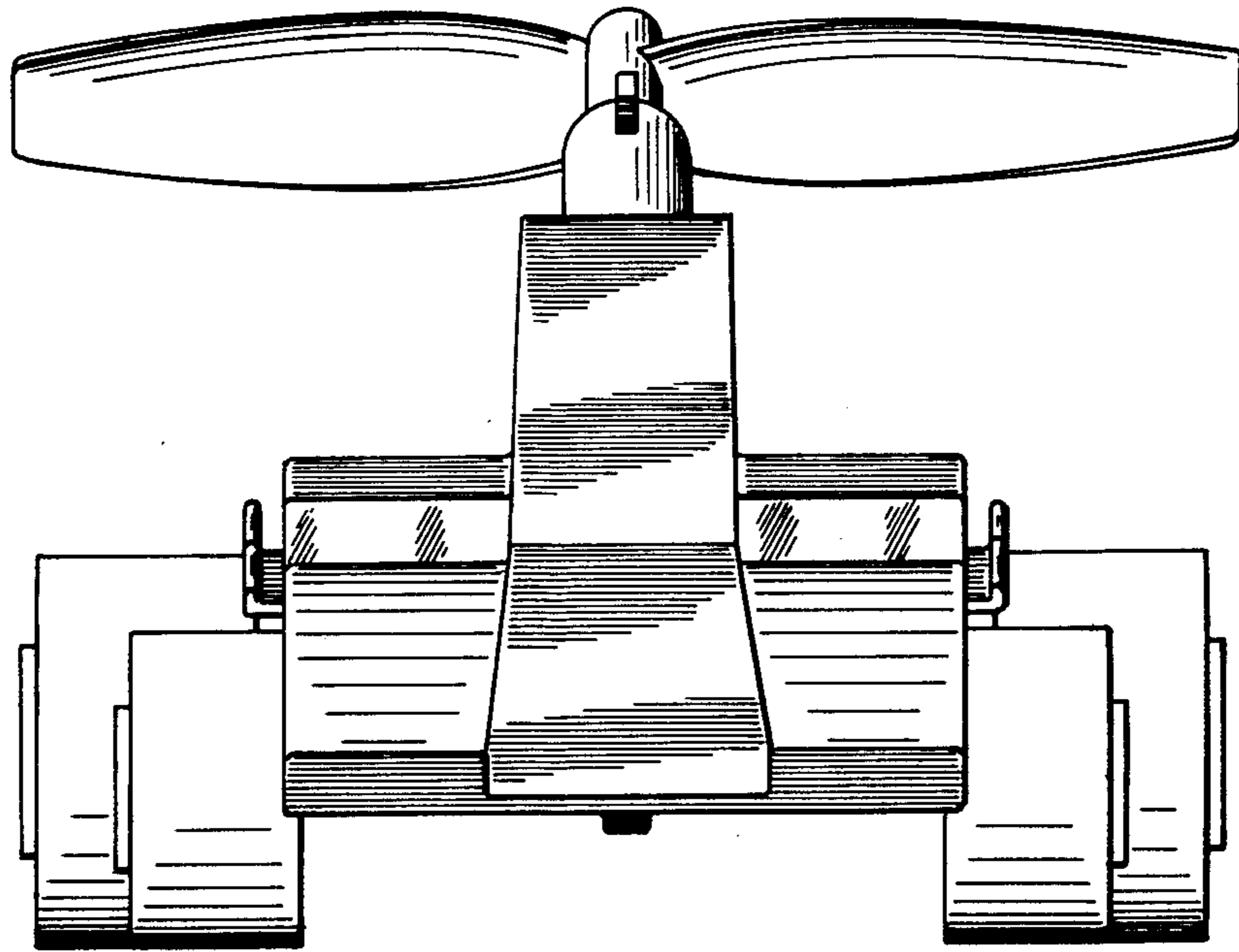

FIG. 4

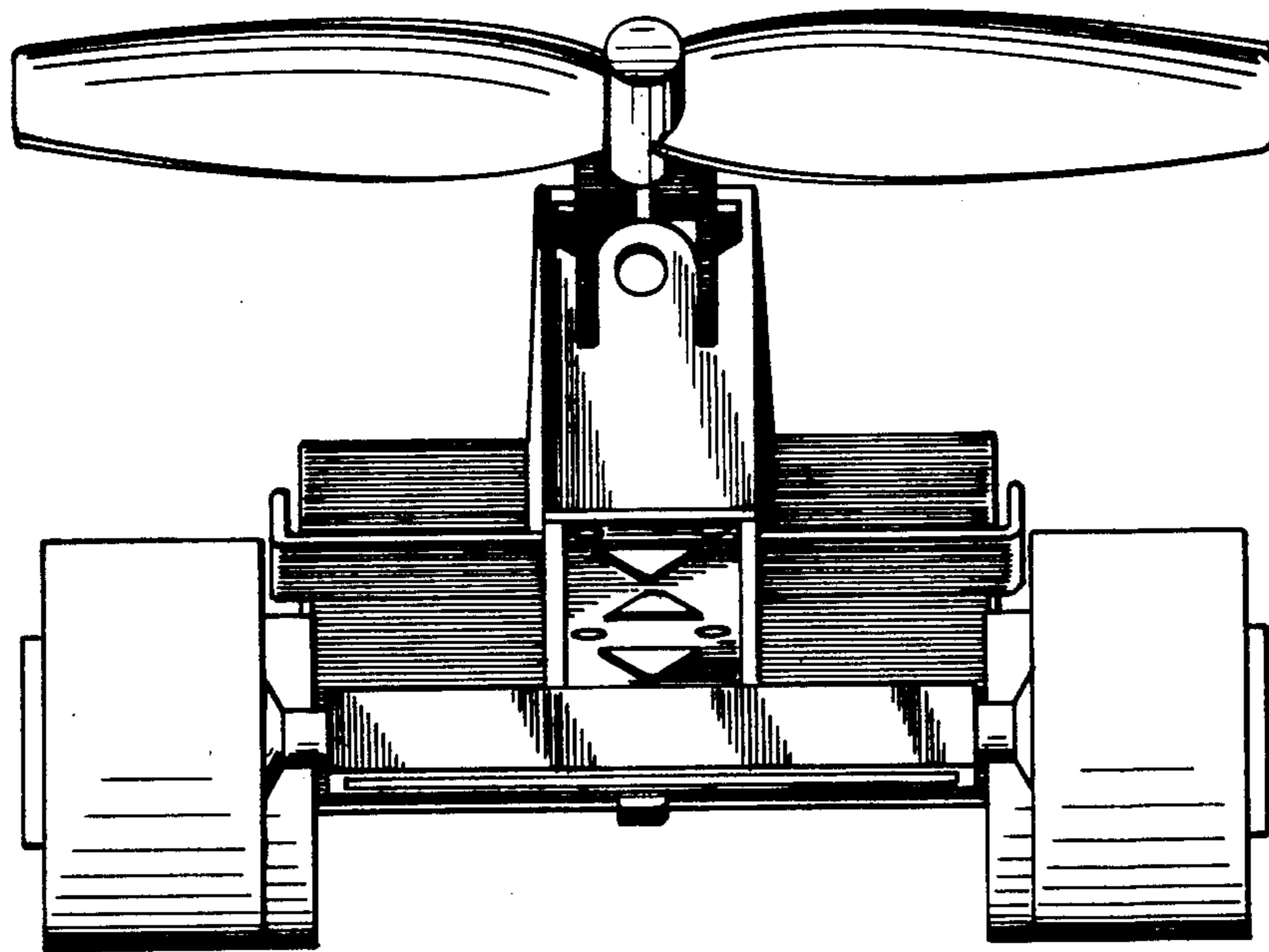

FIG. 5