

[54] SPOKED VEHICLE WHEEL

OTHER PUBLICATIONS

[75] Inventor: Ronald D. Retzlaff, Anaheim, Calif.

Motor Trend, 11/77, P16, Spoke Wheel, top right side of page.

[73] Assignee: Tru-Spoke, Inc., Anaheim, Calif.

71 Dodge Brochure, ©1971, P20, Spoke Wheel, second box down from top & second box in from left side of page.

[**] Term: 14 Years

Street Rod, 8/72, P29, Packard Wheel, bottom left side of page.

[21] Appl. No.: 911,440

Primary Examiner—James M. Gandy

[22] Filed: Jun. 1, 1978

Attorney, Agent, or Firm—Gerald L. Price

[51] Int. Cl. D12-16

[57] CLAIM

[52] U.S. Cl. D12/205

The ornamental design for a spoked vehicle wheel, as shown.

[58] Field of Search D12/205, 209; 301/55, 301/58, 59, 63 R, 63 DD, 63 DT, 63 PW, 64 R, 64 SH, 64 SD, 65, 66, 73, 74, 79, 95, 95 D, 95 C, 375 S

DESCRIPTION

FIG. 1 is a front elevational view of a spoked vehicle wheel showing my new design;

FIG. 2 is an end elevational view thereof;

FIG. 3 is a rear elevational view thereof and,

FIG. 4 is a sectional view thereof taken on line 4-4 of FIG. 3.

[56] References Cited

U.S. PATENT DOCUMENTS

D. 245,415 8/1977 Harty, Jr. D12/209

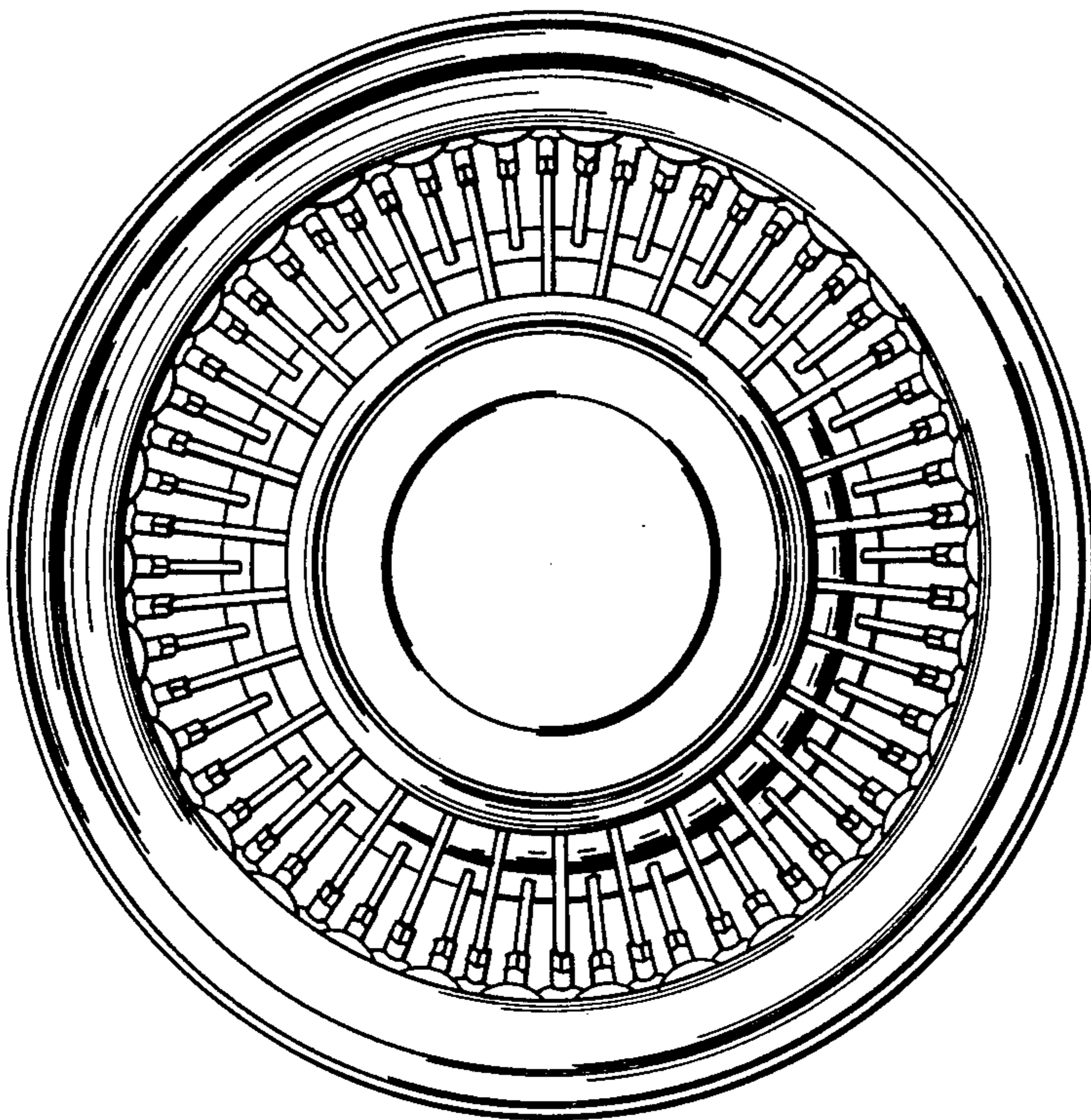

Fig. 1

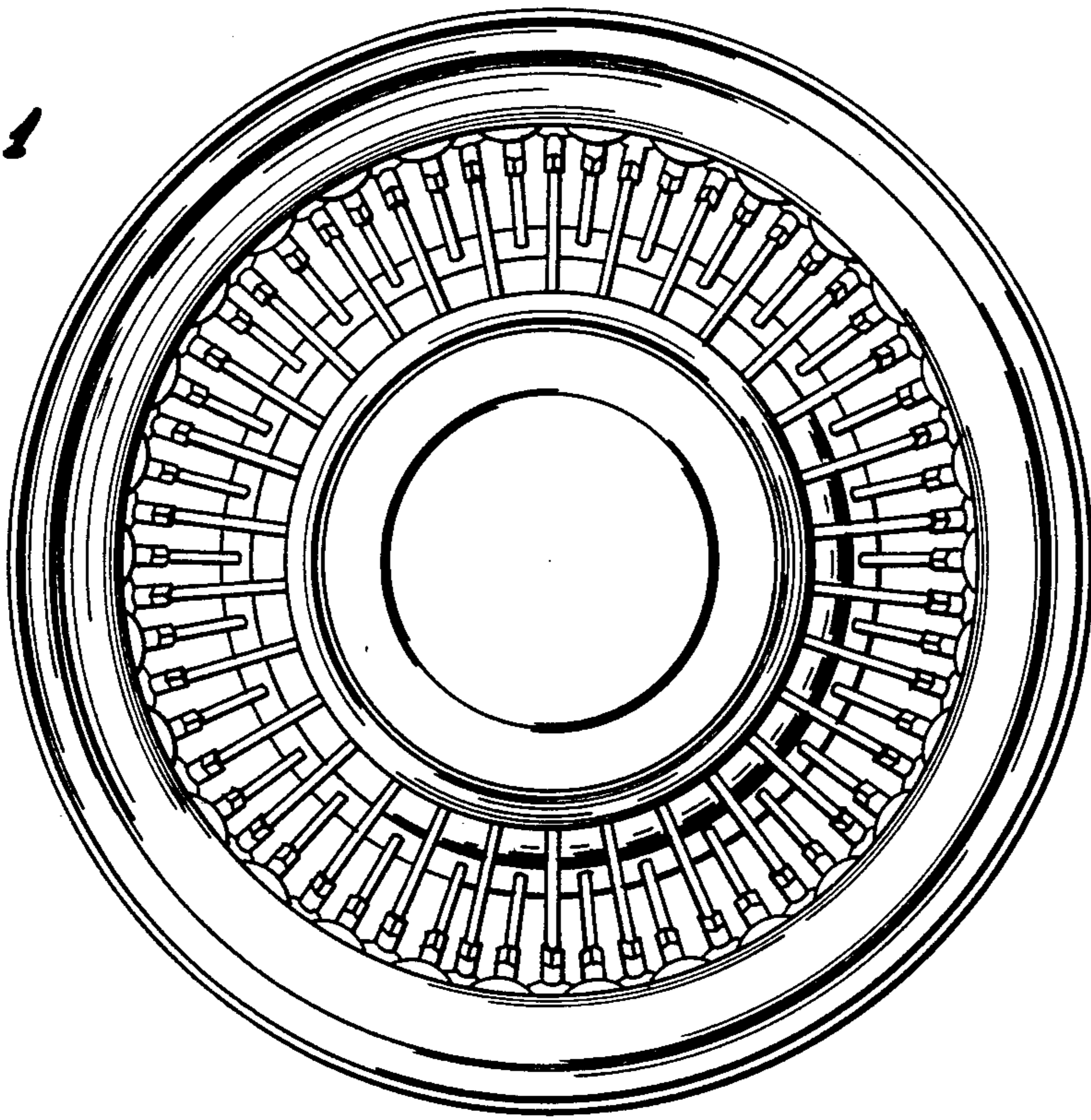

Fig. 2

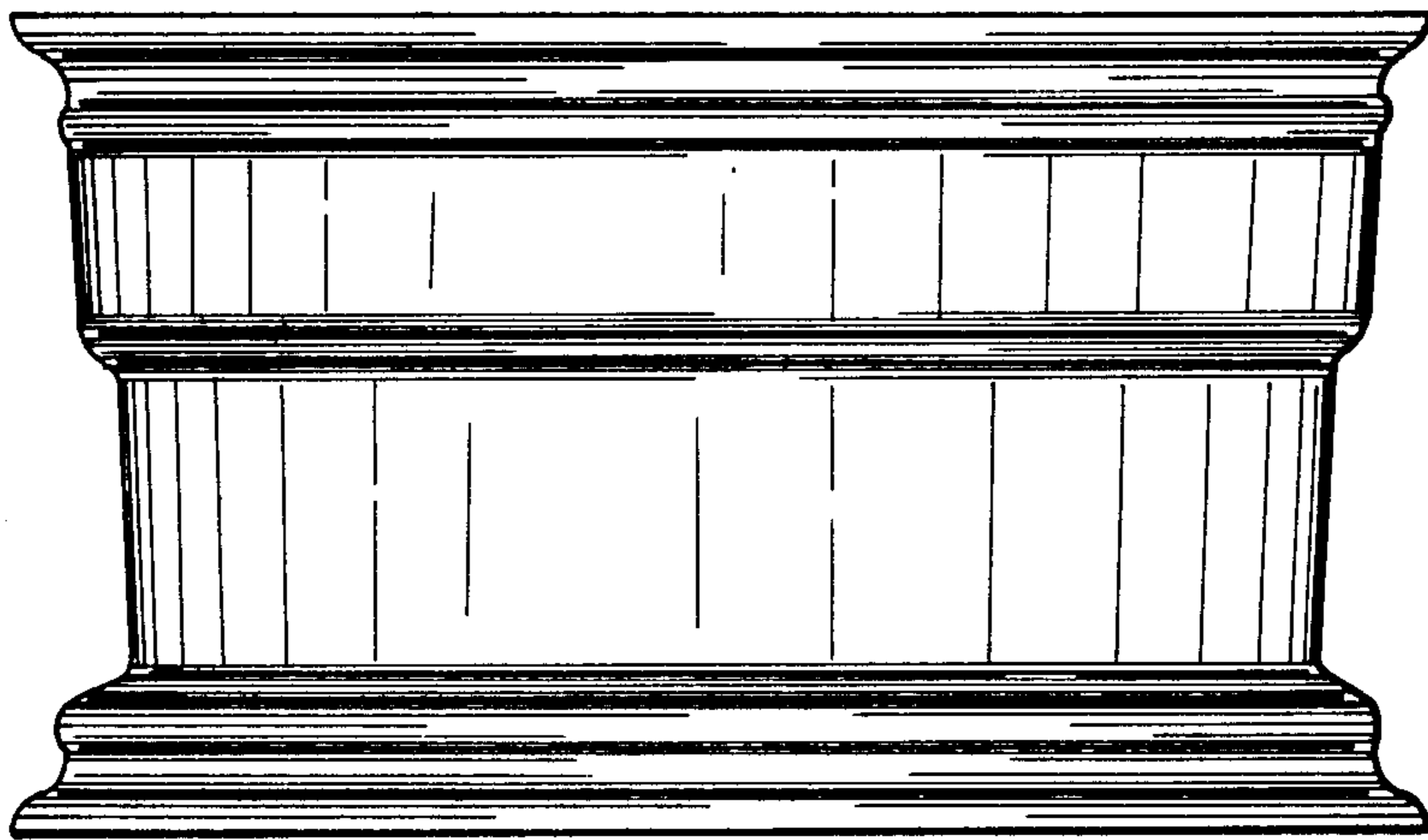

Fig. 3

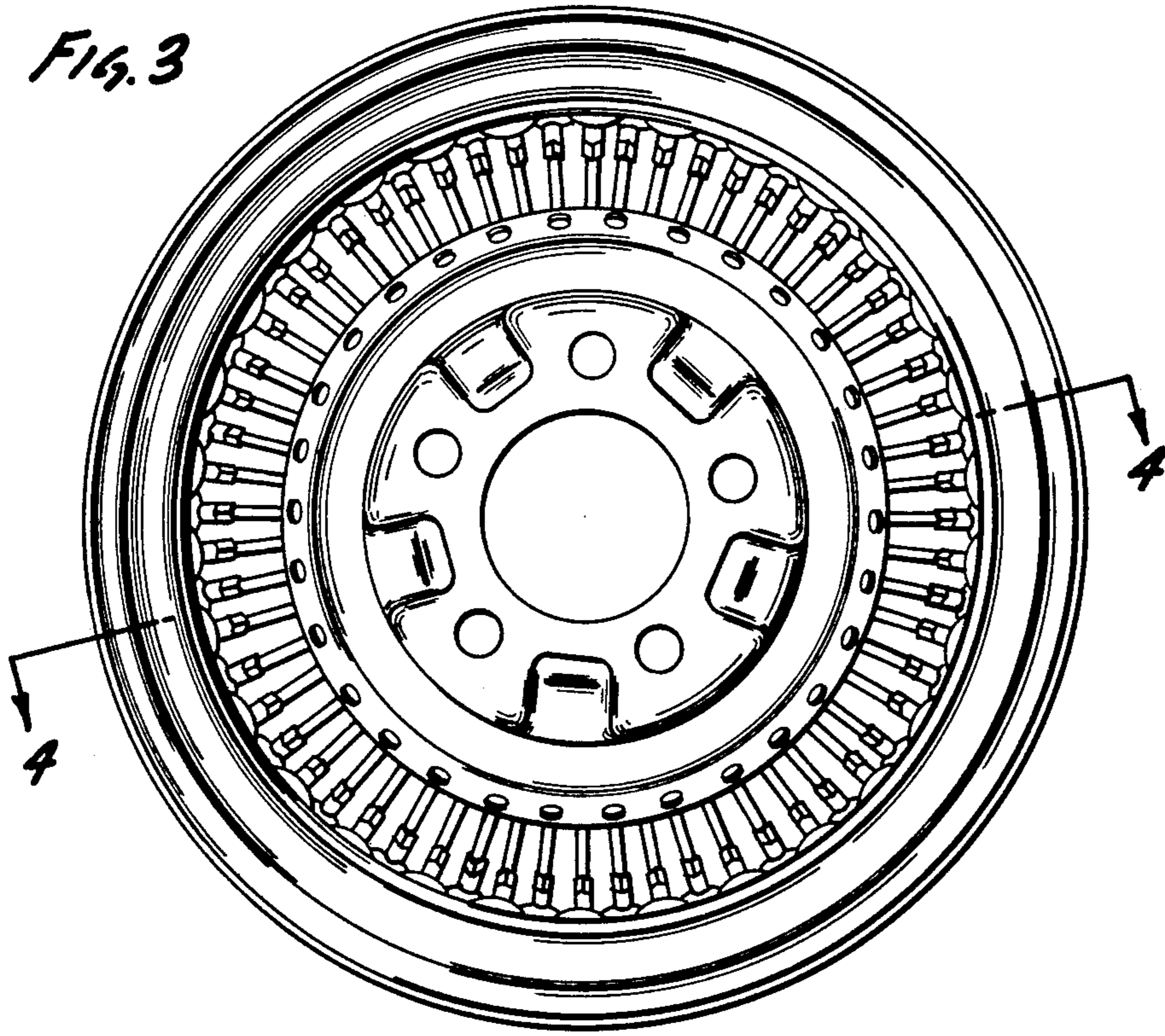

Fig. 4

