

[54] TRANSPORTABLE CAMERA

[75] Inventor: **Rüdolf Viering**, Cologne, Fed. Rep. of Germany

[73] Assignee: **Pixyfoto GmbH**, Cologne, Fed. Rep. of Germany

[**] Term: **14 Years**

[21] Appl. No.: **736,903**

[22] Filed: **Oct. 29, 1976**

[51] Int. Cl. **D16-01**

[52] U.S. Cl. **D16/02**

[58] Field of Search **D16/1-10, D16/44; 354/290, 291, 292, 293, 81, 126, 129, 145, 152, 162, 174, 202, 288**

[56] **References Cited**

U.S. PATENT DOCUMENTS

D. 241,739	10/1976	Farey et al.	D16/01
3,105,430	10/1963	Fernelius	D16/44 X
3,227,509	1/1966	Baker	354/291 X

3,323,429	6/1967	Howard	D16/3 X
3,350,980	11/1967	Margolin	354/291 X
3,812,506	5/1974	Klebanow	354/290 X
3,970,835	7/1976	Crete	354/290 X

Primary Examiner—Wallace R. Burke
Assistant Examiner—Catherine Kemper
Attorney, Agent, or Firm—Omri M. Behr

[57] **CLAIM**

The ornamental design for a transportable camera, as shown.

DESCRIPTION

FIG. 1 is a side elevational view of a transportable camera showing my new design;
 FIG. 2 is an elevational view of the opposite side thereof;
 FIG. 3 is a bottom plan view thereof;
 FIG. 4 is a rear elevational view thereof;
 FIG. 5 is a top plan view thereof;
 FIG. 6 is a front elevational view thereof.
 FIG. 7 is a front perspective view thereof;
 FIG. 8 is a rear perspective view thereof.

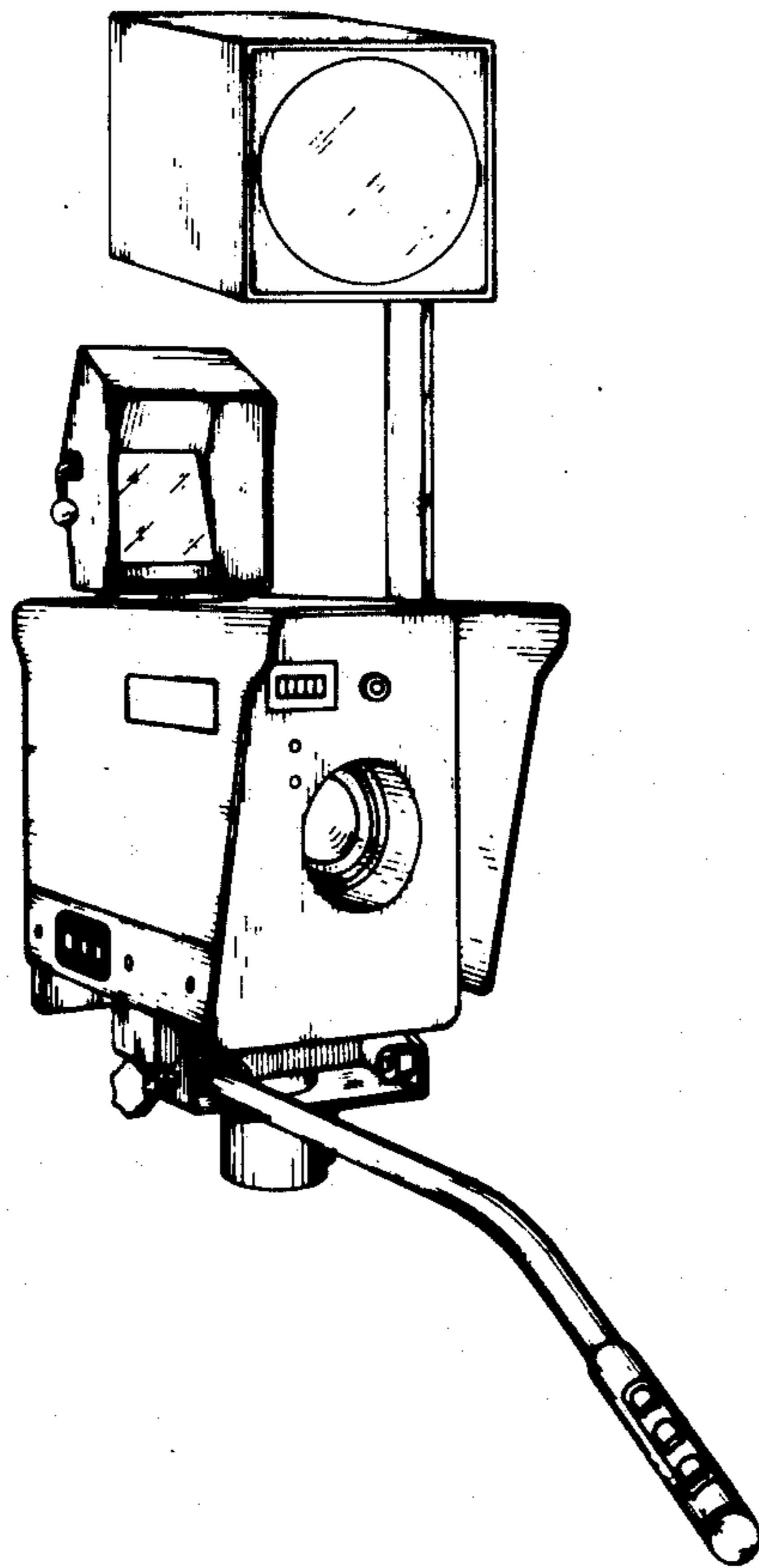
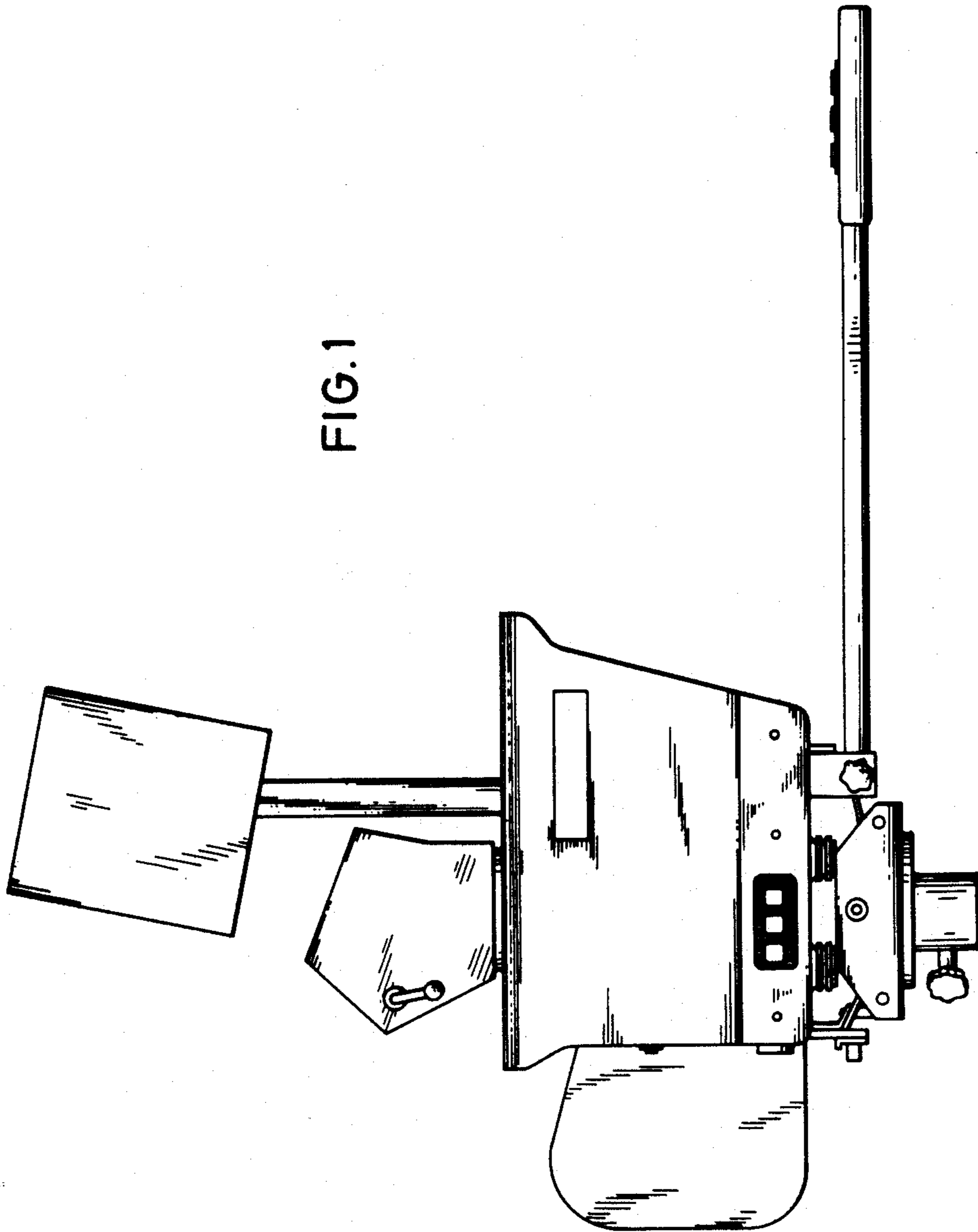

FIG. 1



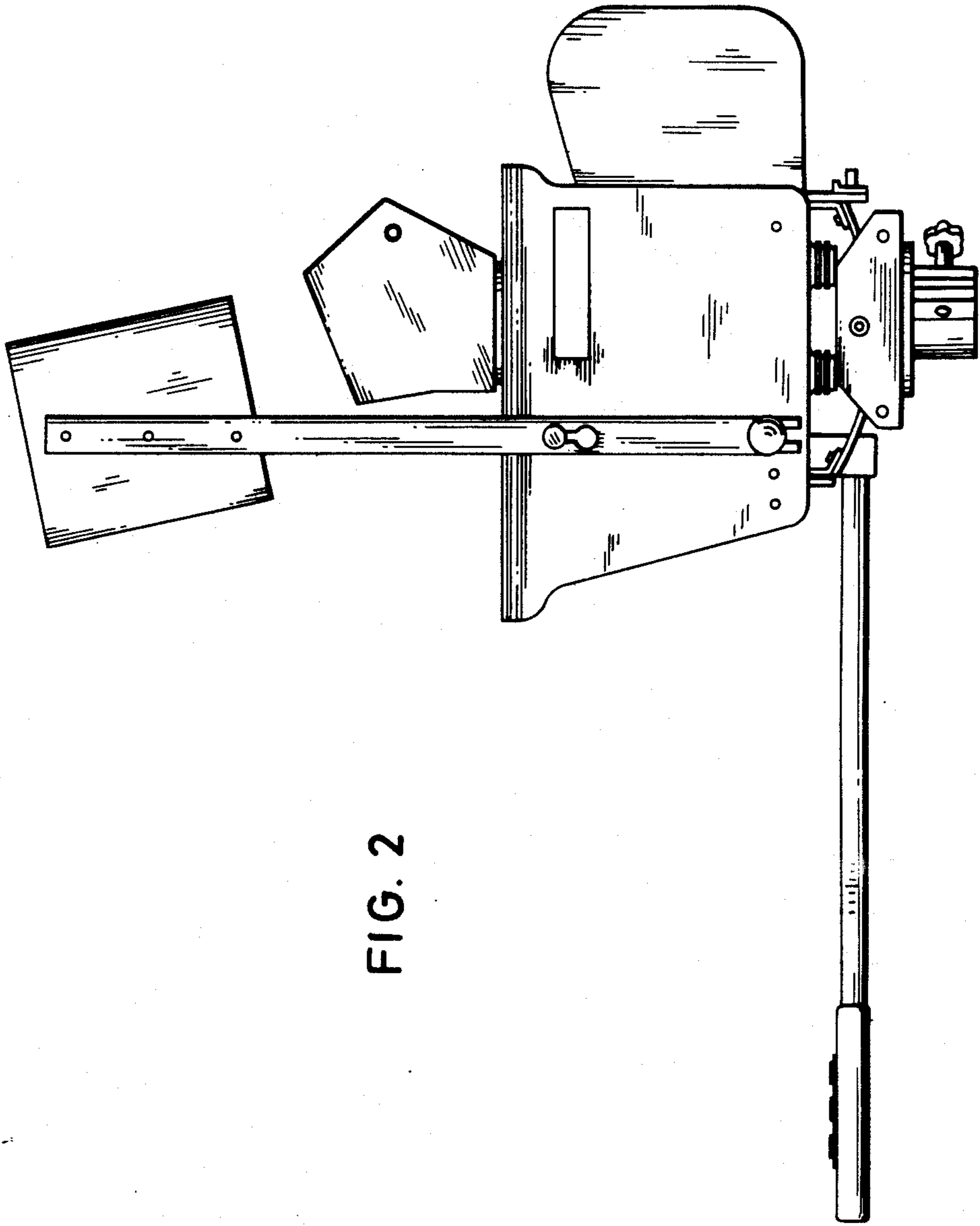

FIG. 2

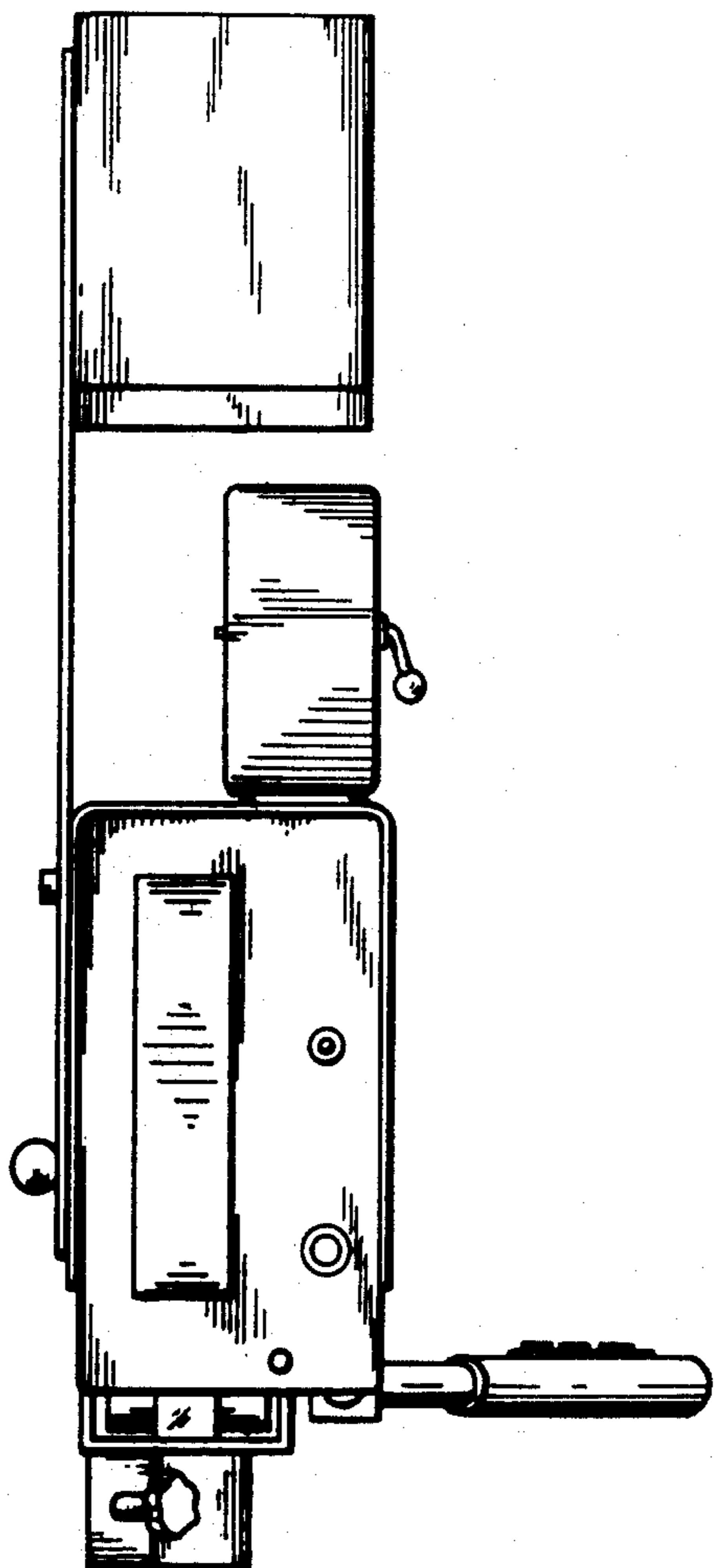

FIG. 4

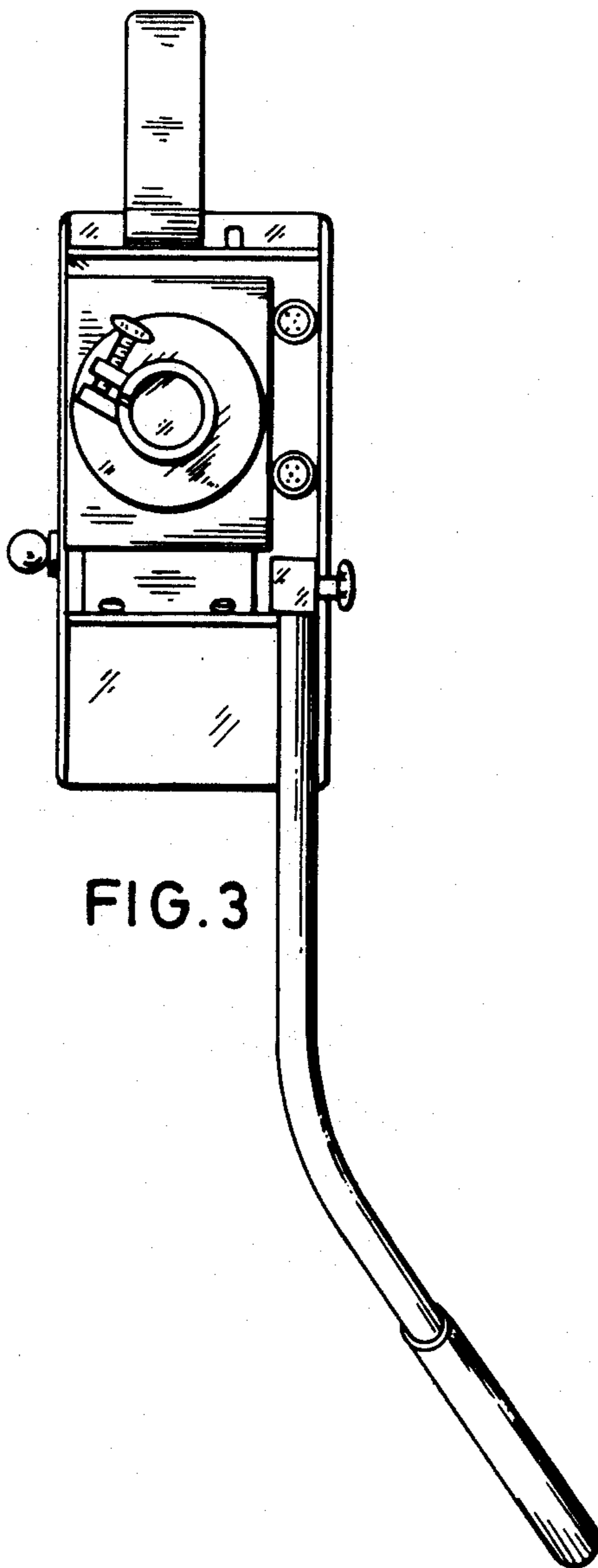

FIG. 3

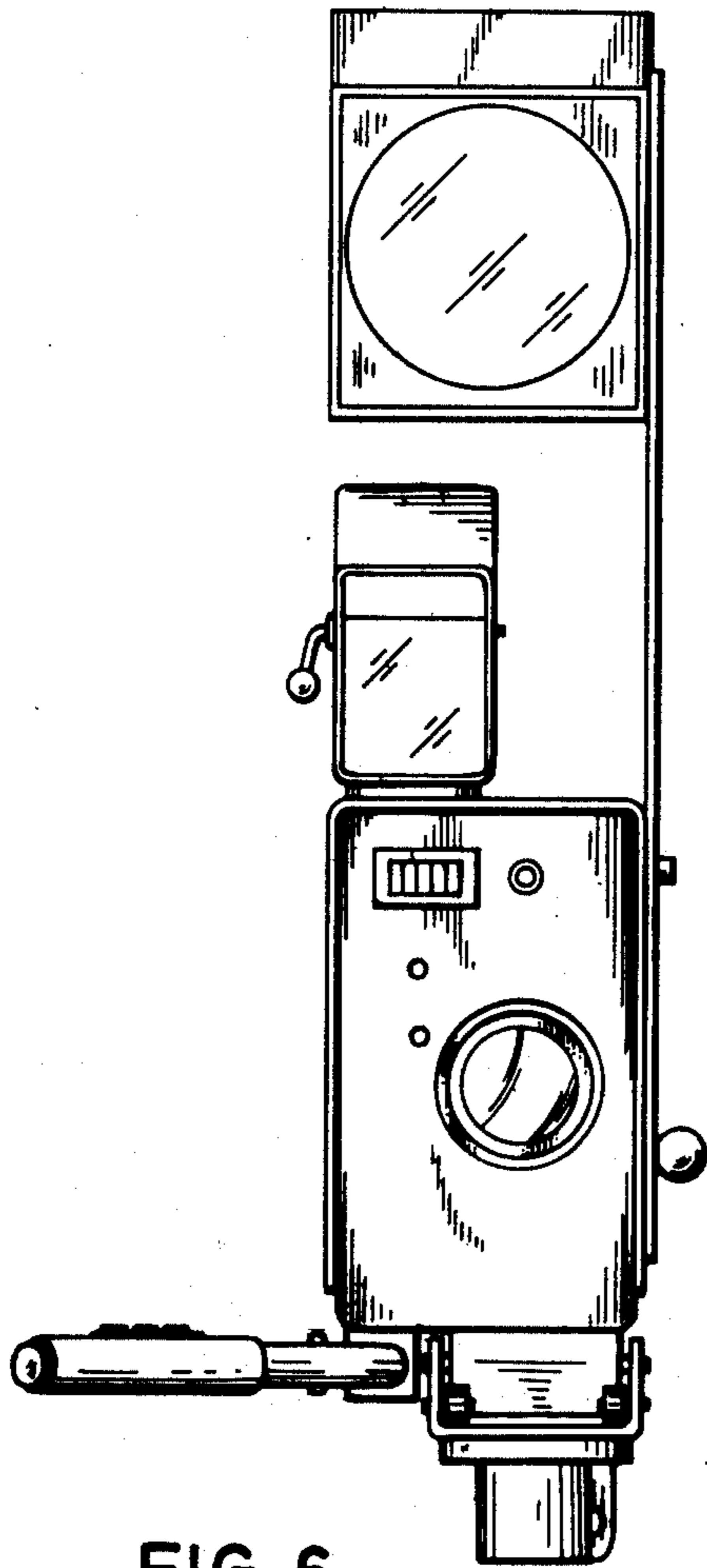

FIG. 6

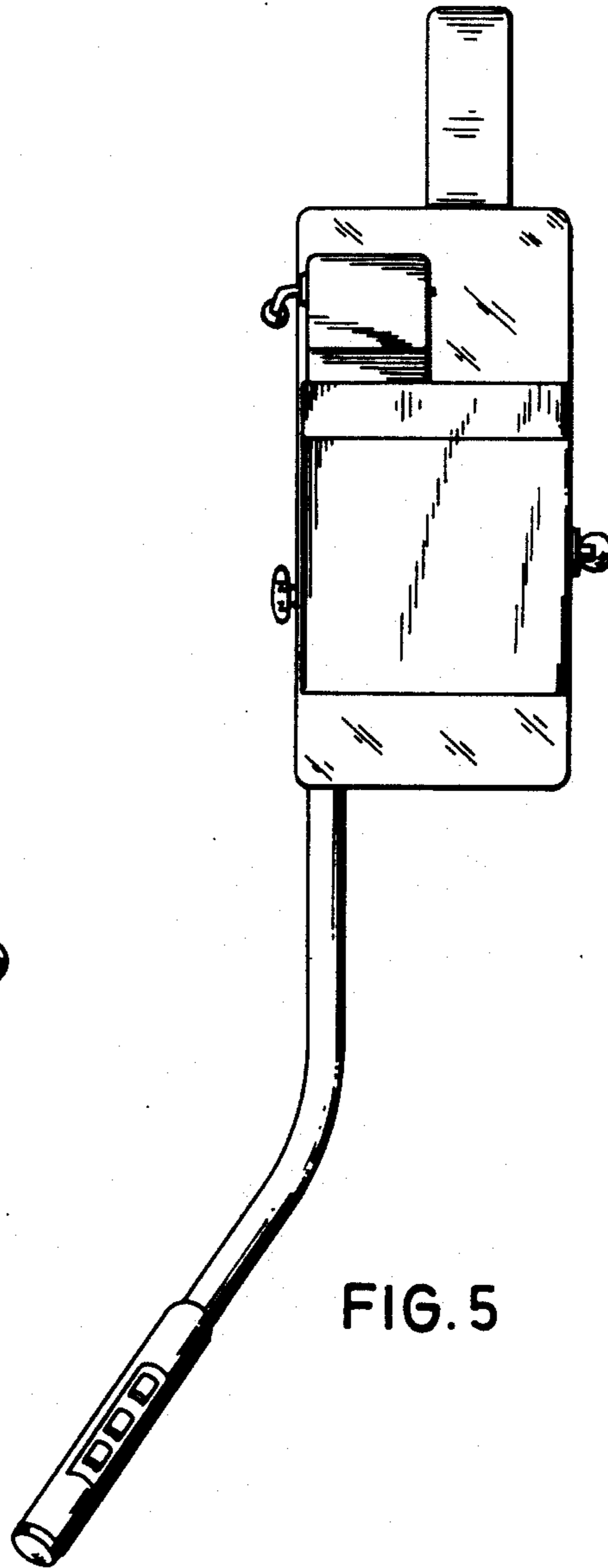

FIG. 5

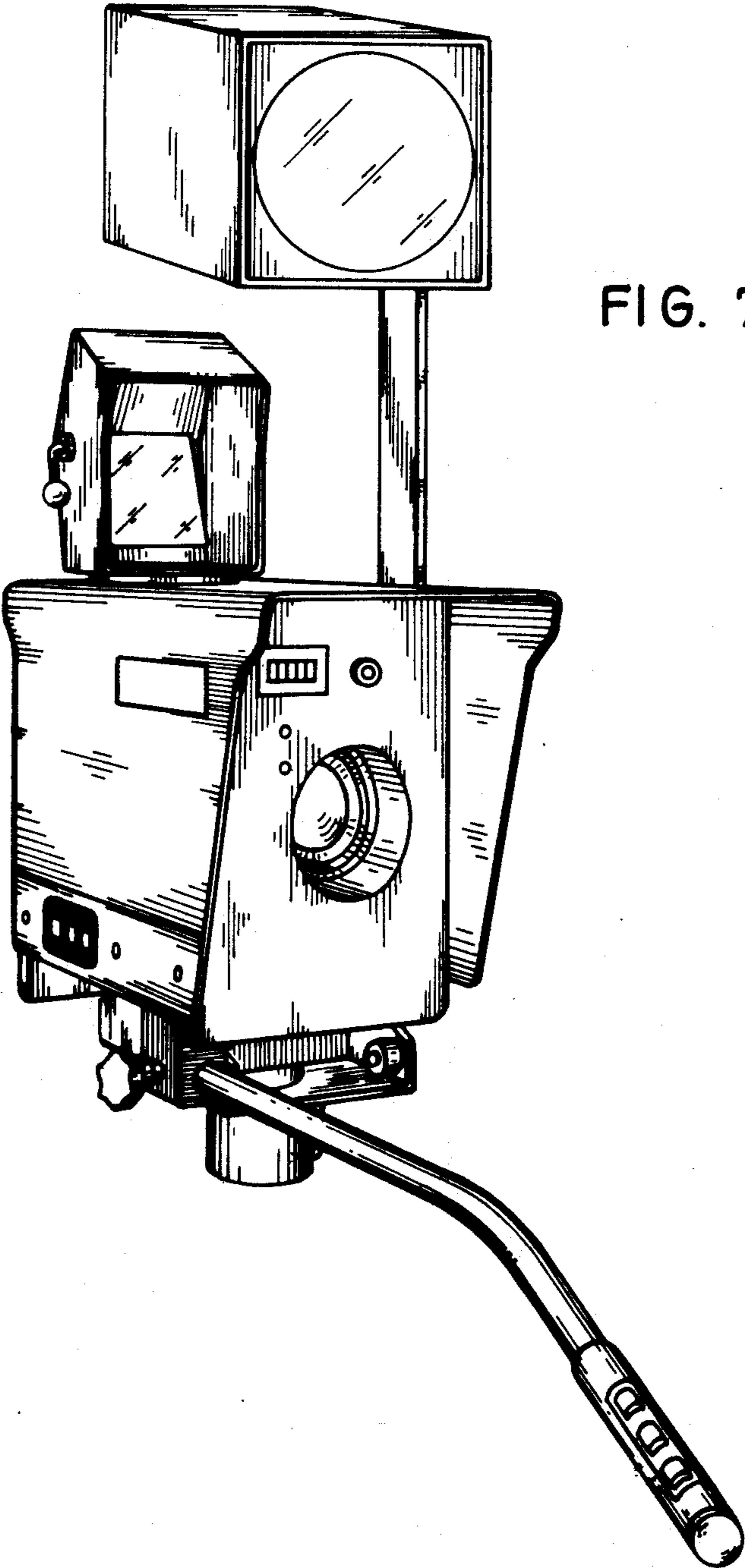

FIG. 7

FIG. 8

