

[54] **STAND MOUNT FOR A GUITAR, OR THE LIKE**

4,014,240 3/1977 Pullen ..... 84/327

[76] Inventor: **Floye K. Dreyer, 101 NE. 165th St., North Miami Beach, Fla. 33162**

**FOREIGN PATENT DOCUMENTS**

398499 7/1924 Fed. Rep. of Germany ..... 84/327  
361439 7/1938 Italy ..... 84/327

[\*\*] Term: **14 Years**

*Primary Examiner—Joel Stearman*  
*Assistant Examiner—Jane E. Corrigan*  
*Attorney, Agent, or Firm—Laurence R. Brown*

[21] Appl. No.: **746,931**

[22] Filed: **Dec. 2, 1976**

[57] **CLAIM**

[51] Int. Cl. .... **D17-99; D17-03; D6-06; D6-99**

The ornamental design for a stand mount for a guitar, or the like, substantially as shown and described.

[52] U.S. Cl. .... **D17/20; D6/85**

**DESCRIPTION**

[58] Field of Search ..... **D56/1 R, 1 A; D6/85; 84/327, 452 R**

FIG. 1 is a front, top and left side perspective view of a stand mount for a guitar or the like showing my new design;

[56] **References Cited**

**U.S. PATENT DOCUMENTS**

2,814,229 11/1957 Vaccaro et al. .... 84/327

FIG. 2 is a front and right side perspective view;

FIG. 3 is a front elevational view; and

FIG. 4 is a left side elevational view.

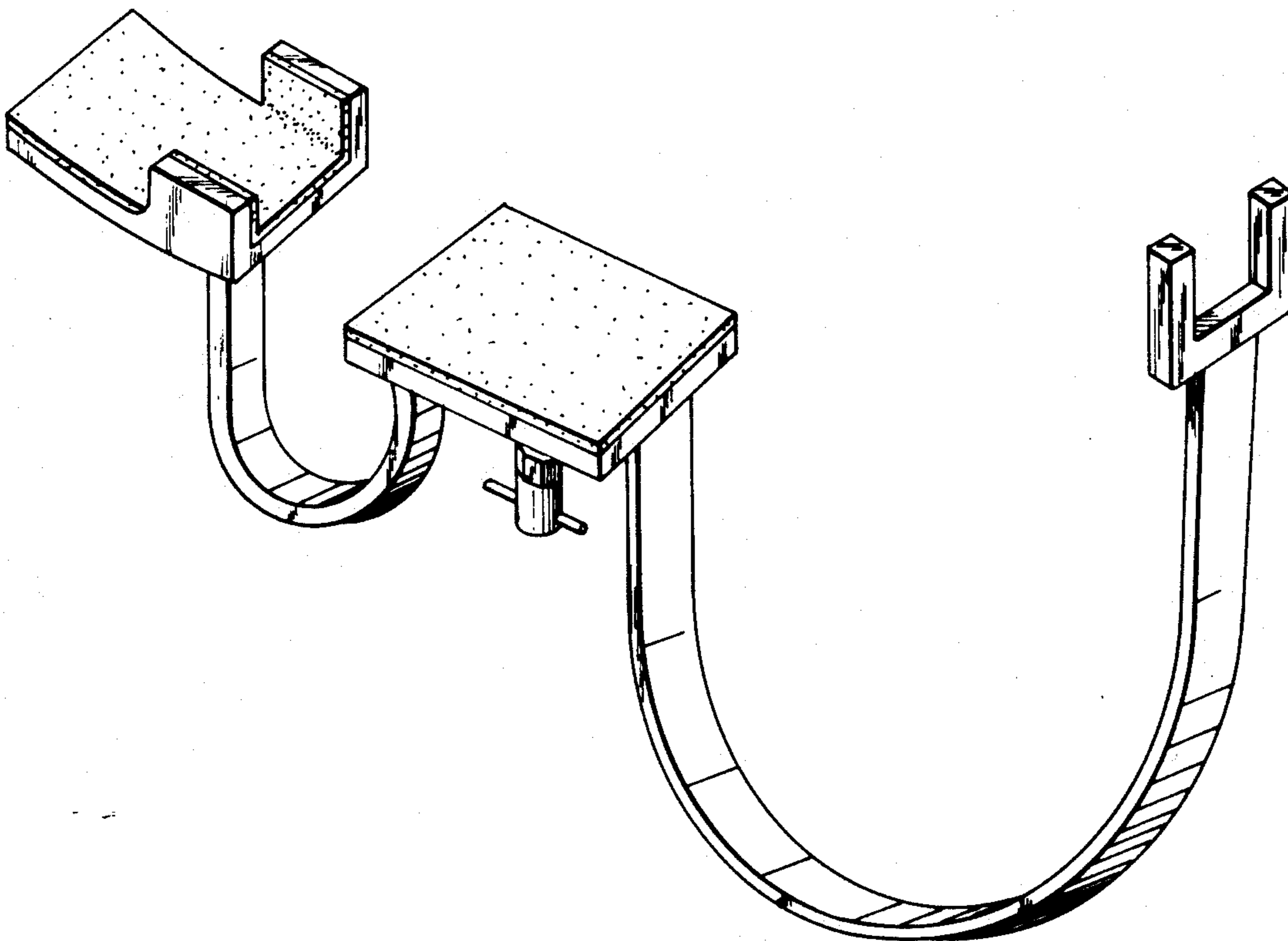

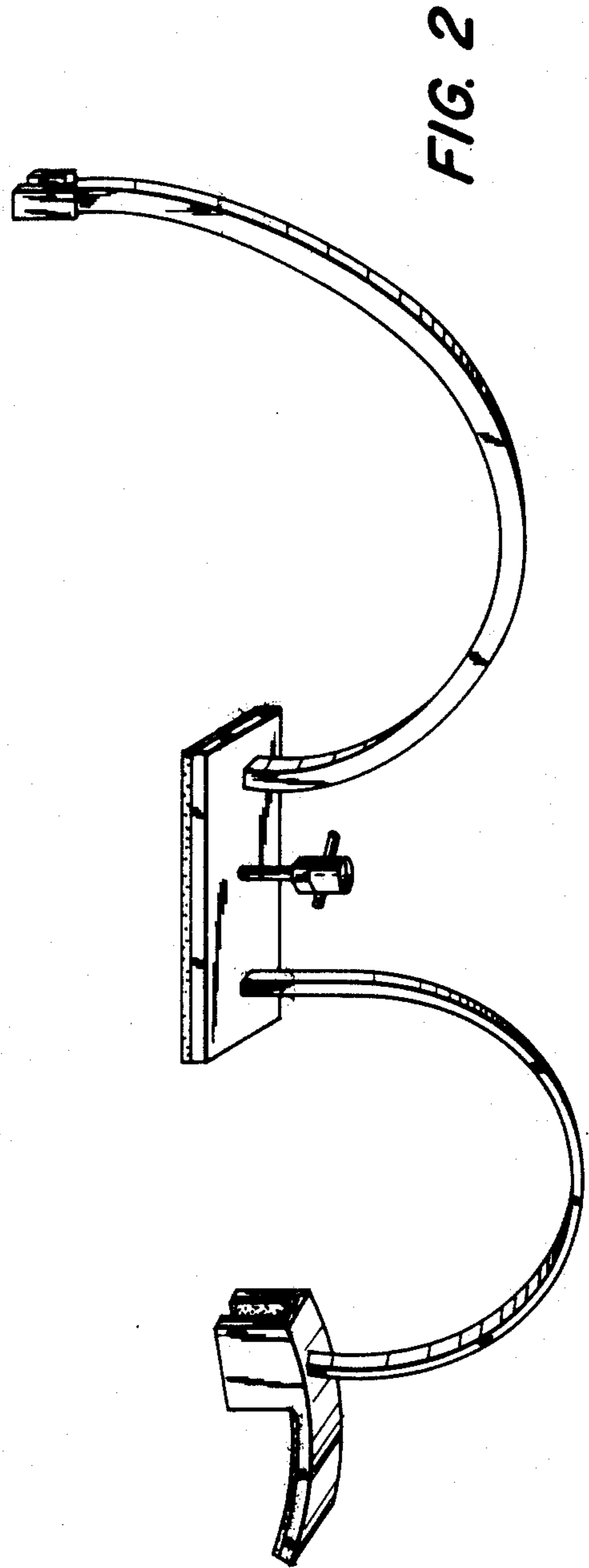
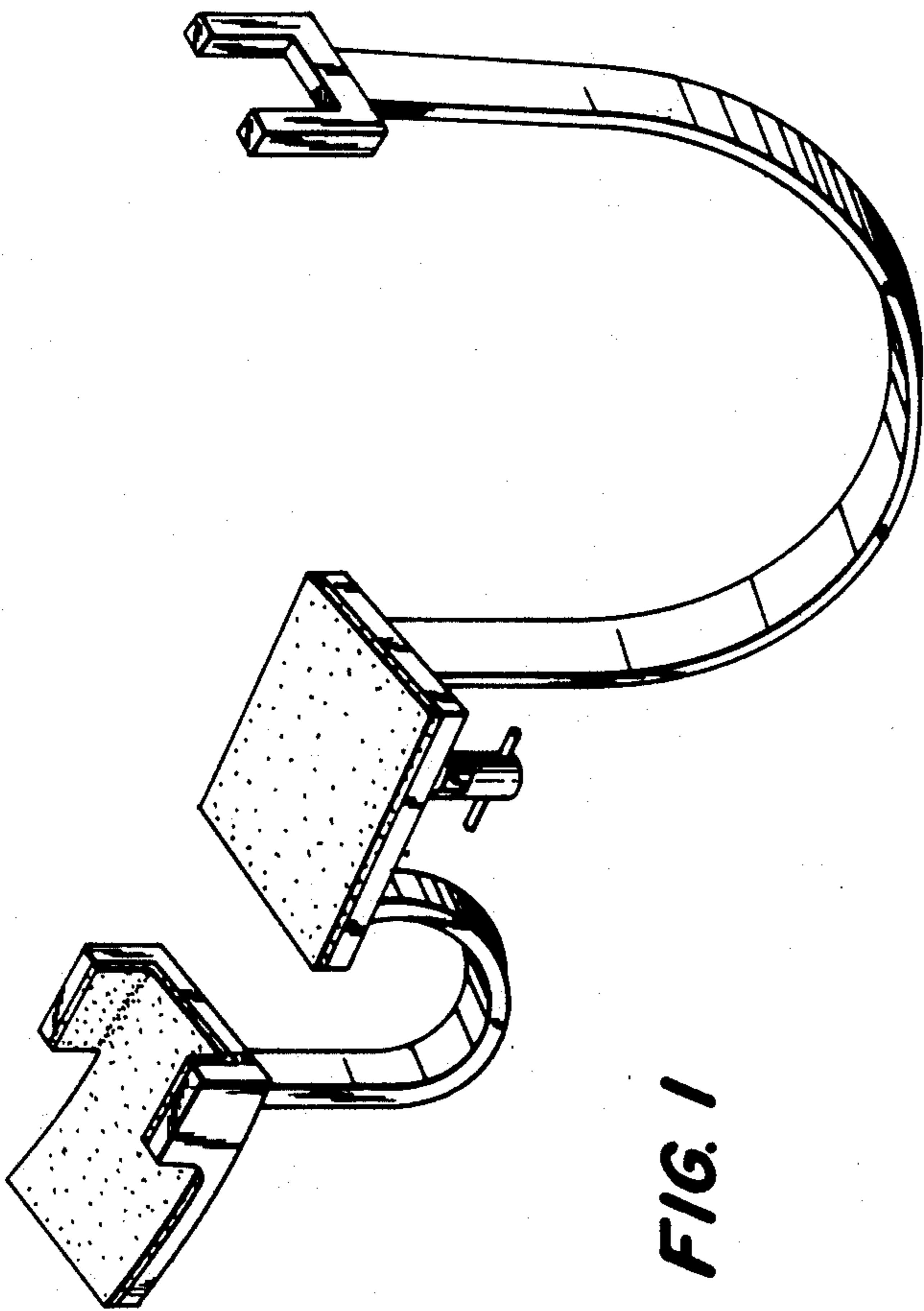

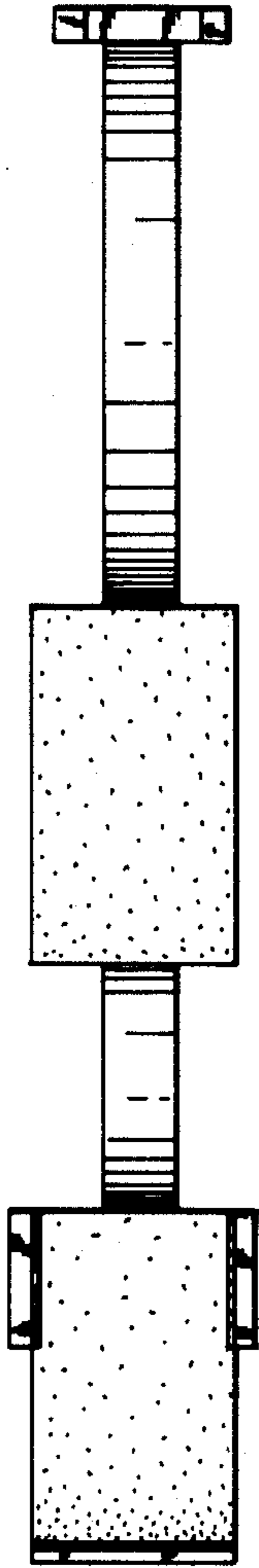

**FIG. 4**

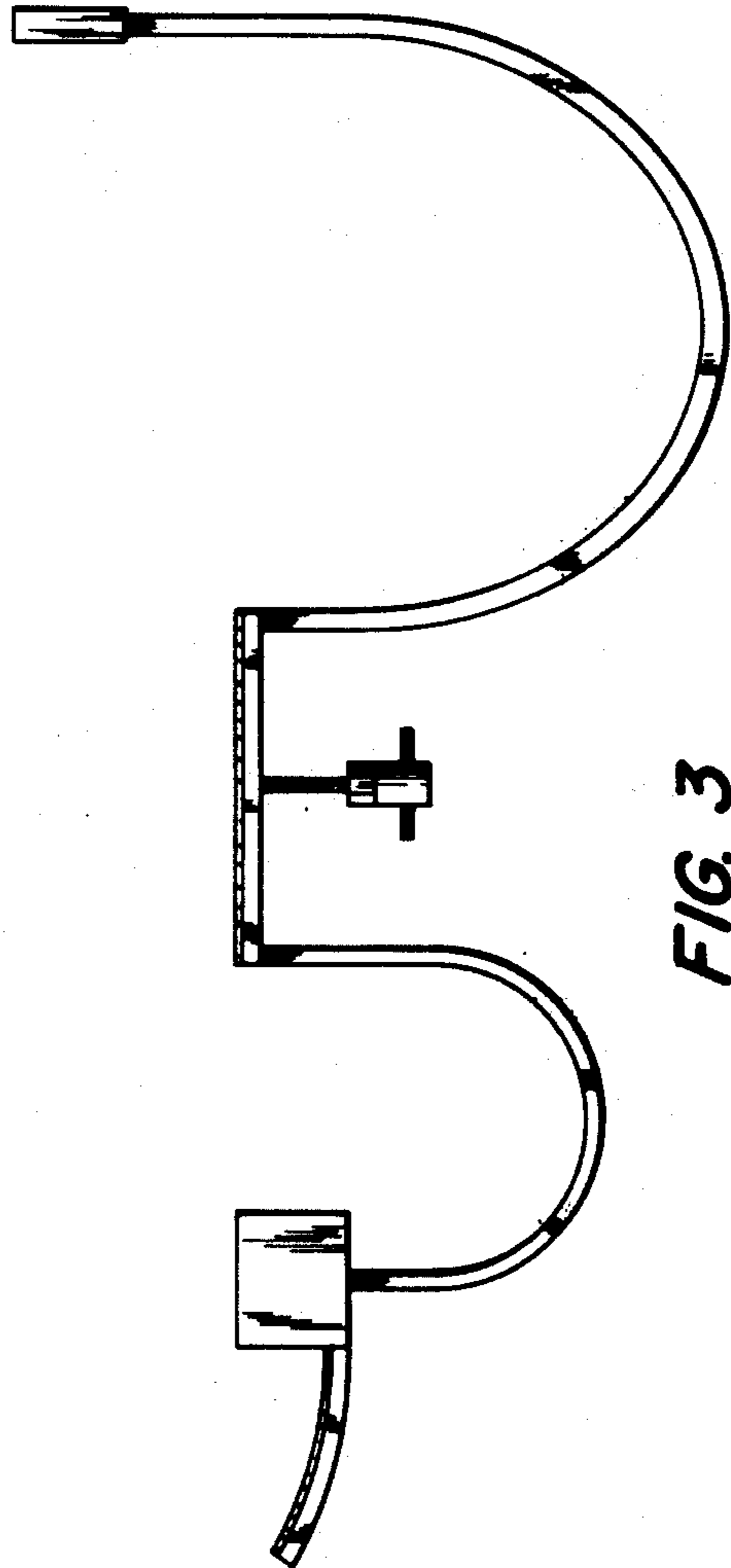

**FIG. 3**