

[54] MOTOR-CYCLE FAIRING

[75] Inventor: Craig W. Vetter, Rantoul, Ill.

[73] Assignee: Vetter Fairing Company, Rantoul, Ill.

[**] Term: 14 Years

[21] Appl. No.: 848,776

[22] Filed: Nov. 4, 1977

Related U.S. Application Data

[63] Continuation-in-part of Ser. No. 802,240, May 31, 1977, abandoned.

[51] Int. Cl. D12-11

[52] U.S. Cl. D12/182

[58] Field of Search D12/182; 296/78.1; 280/289.5

[56] References Cited

PUBLICATIONS

Cycle, 4/76, p. 67, Windjammer Fairing without Lowers, bottom left side of page.

Cycle, 4/76, p. 17, Fairing, center of page.

Cycle, 4/76, p. 91, Tour Master Fairing, bottom of page.

Cycle, 6/76, p. 25, Free Spirit Fairing, top right side of page.

Cycle, 6/76, p. 116, Wixom Fairing, bottom of page.

Primary Examiner—James M. Gandy

Attorney, Agent, or Firm—Ernest A. Wegner

[57] CLAIM

The ornamental design for a motorcycle fairing, as shown and described.

DESCRIPTION

FIG. 1 is a front elevation view of a motorcycle fairing showing the new design;

FIG. 2 is a rear elevation view thereof;

FIG. 3 is a left side elevation view thereof;

FIG. 4 is a right side elevation view thereof;

FIG. 5 is a top plan view thereof.

The fragmentary broken line representations of portions of a motorcycle in FIGS. 3, and 4, illustrate the environment in which the fairing is used but form no part of my design.

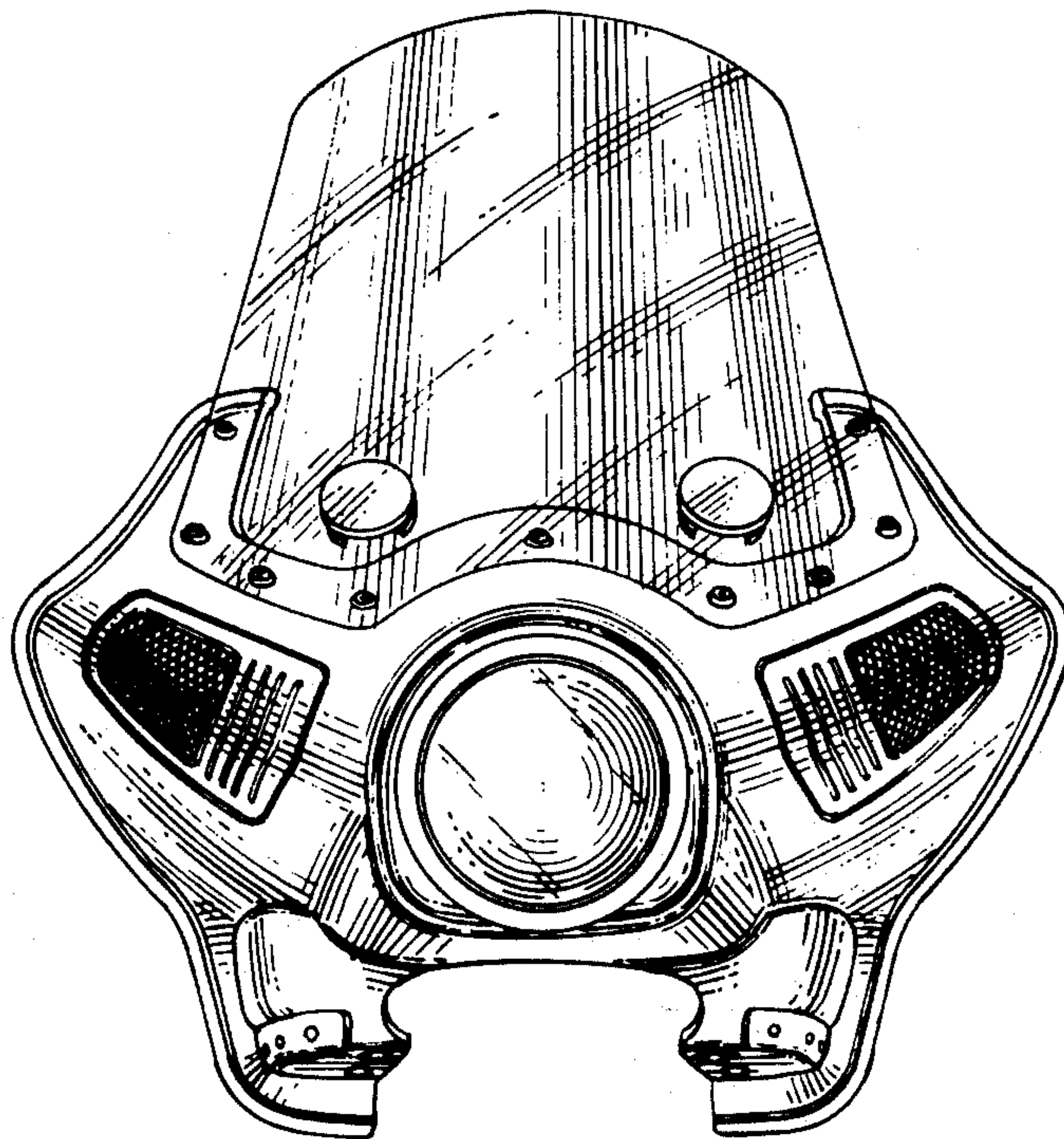

Fig. 2

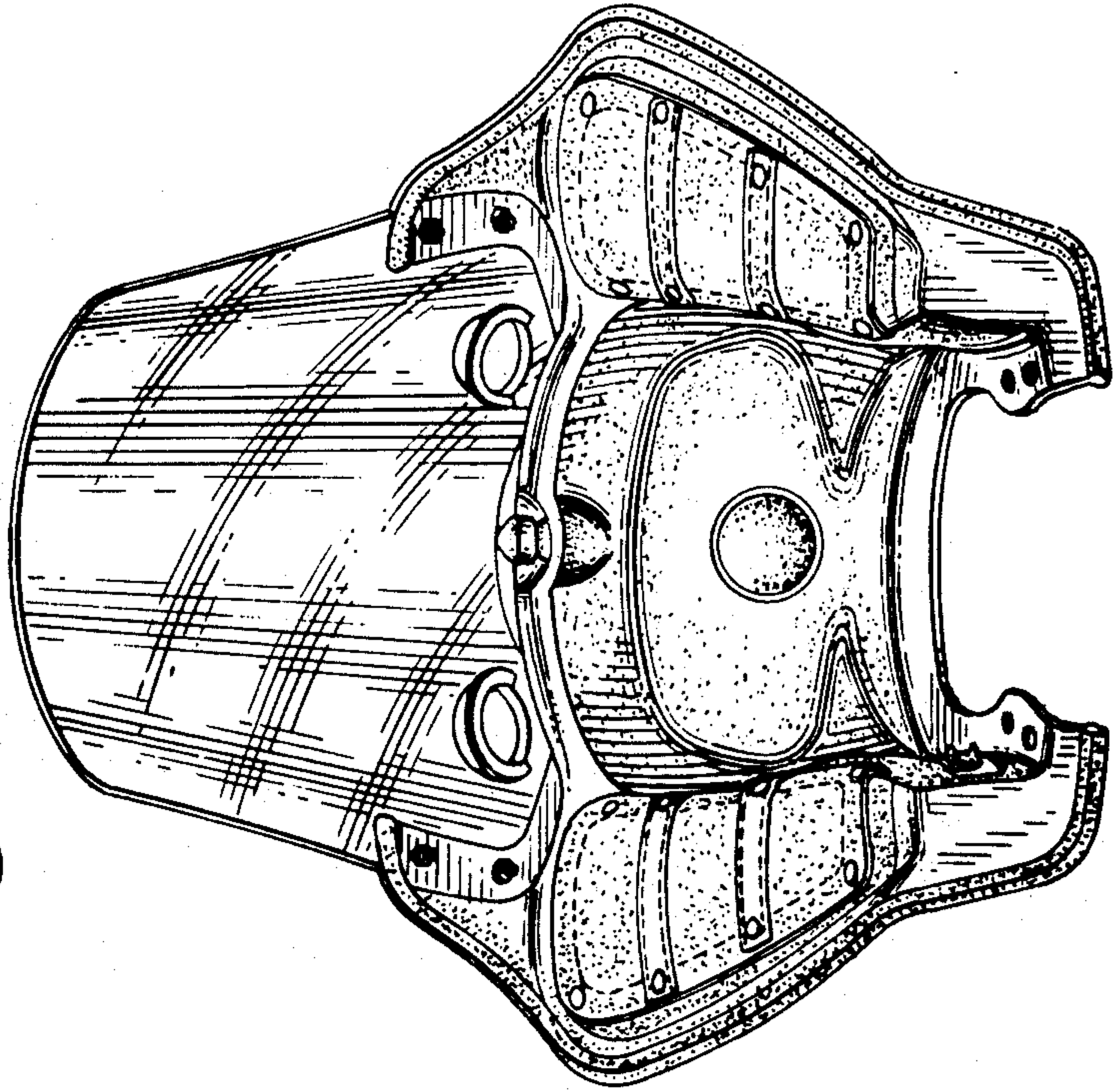
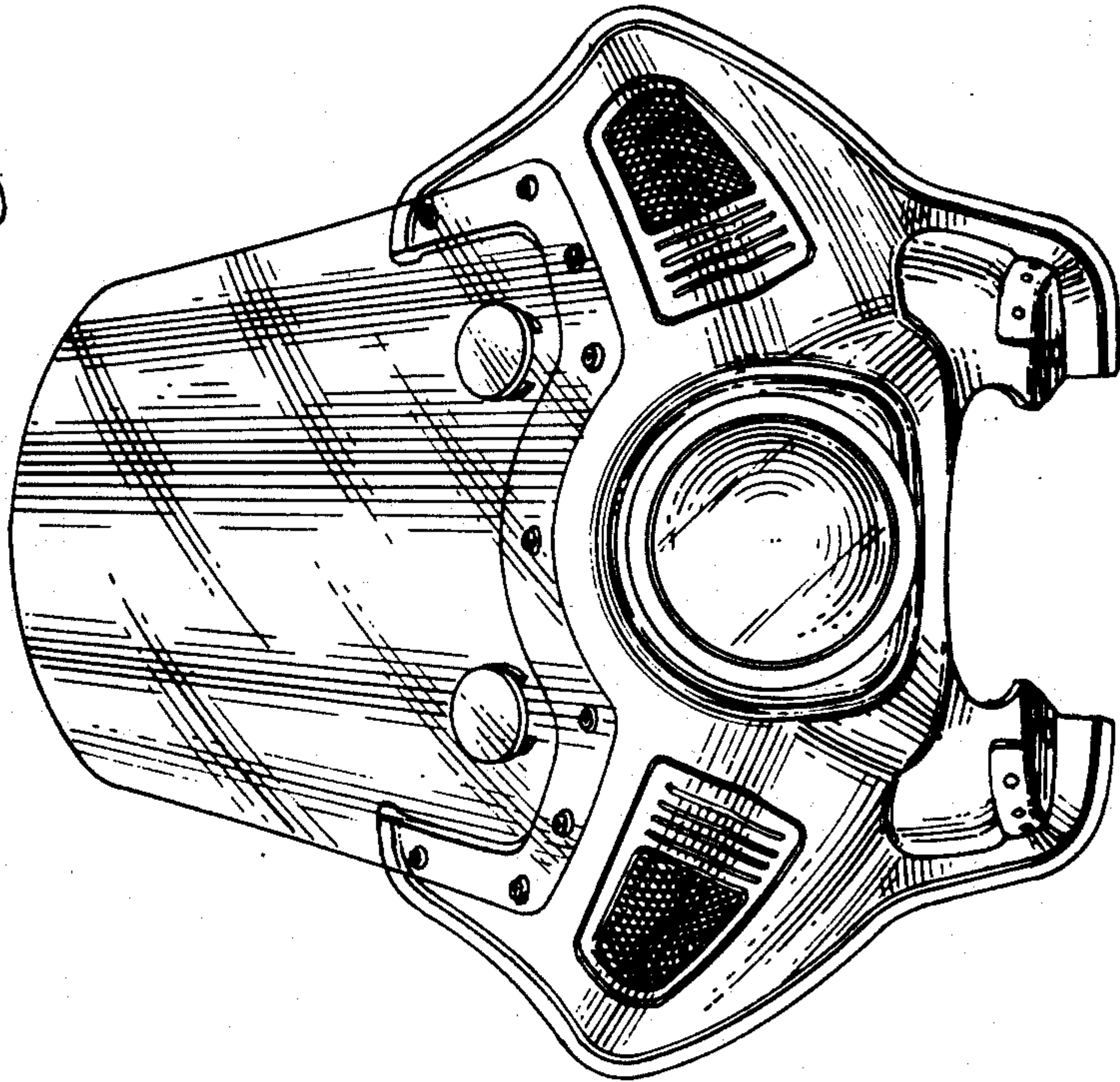

Fig. 1



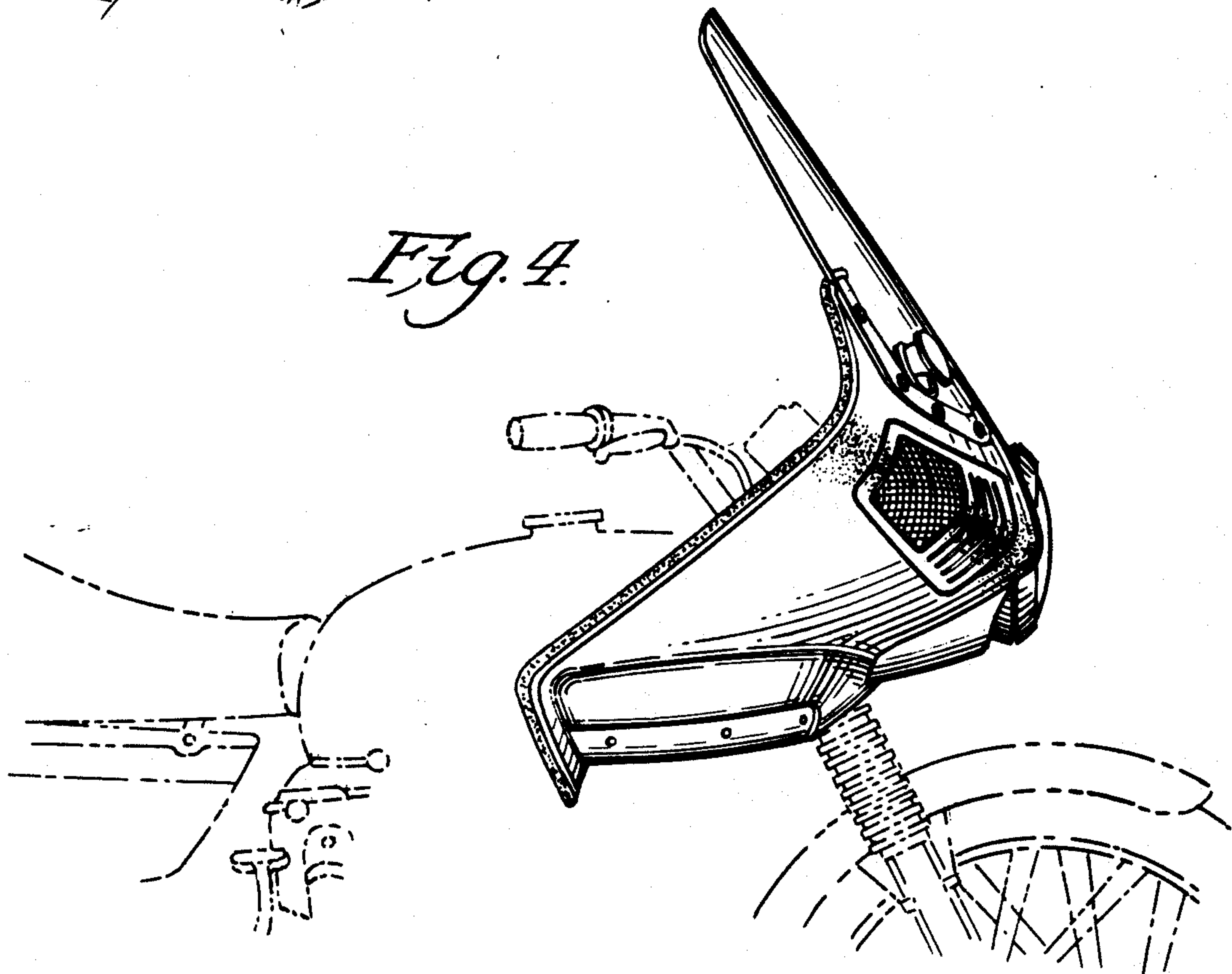
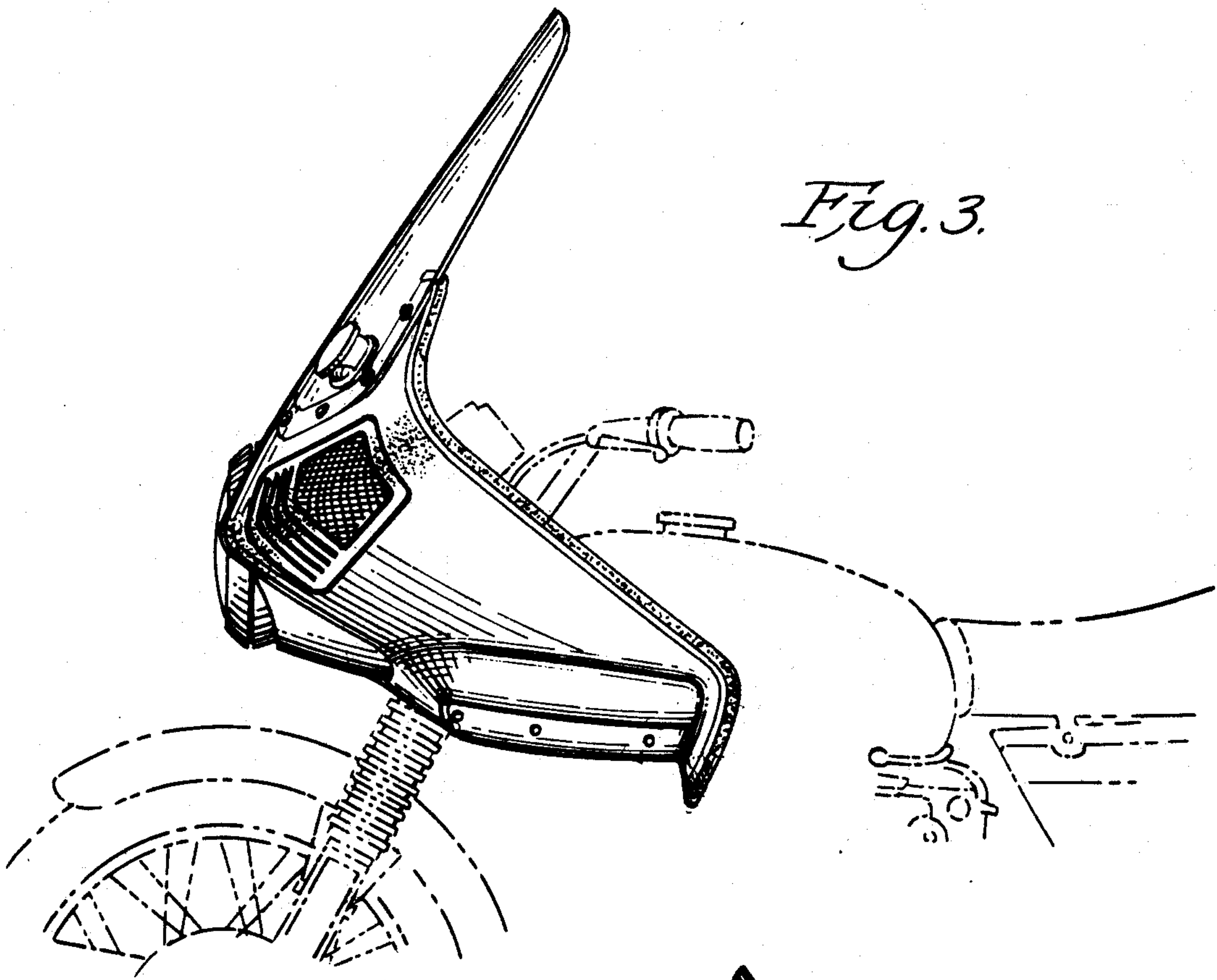

Fig. 5.

