

[54] COMBINATION PLEASURE AND FISHING BOAT

[75] Inventor: Forrest L. Wood, Flippin, Ark.

[73] Assignee: Wood Manufacturing Company, Incorporated, Flippin, Ark.

[**] Term: 14 Years

[21] Appl. No.: 771,336

[22] Filed: Feb. 23, 1977

[51] Int. Cl. D12-06

[52] U.S. Cl. D12/62

[58] Field of Search D12/62

[56] References Cited PUBLICATIONS

Boating, Oct. 1967, p. 91, Glastron's V-160 Boat on page. MonArk Boats 1976 Catalog, cover and p. 5, McFast 5 Boat.

Primary Examiner—Alan P. Douglas Attorney, Agent, or Firm—Wayne B. Stone, Jr.

[57] CLAIM

The ornamental design for a combination pleasure and fishing boat, as shown and described.

DESCRIPTION

FIG. 1 is a top plan view of the combination pleasure and fishing boat; FIG. 2 is an elevational view taken from the right side of the boat; FIG. 3 is a bottom plan view of the boat; FIG. 4 is a front elevational view of the boat; FIG. 5 is a rear elevational view of the boat; FIG. 6 is a top plan view of a second embodiment of the boat; FIG. 7 is an elevational view taken from the right side of the second embodiment of the boat; FIG. 8 is a front elevational view of the second embodiment of the boat; and FIG. 9 is a rear elevational view of the second embodiment of the boat. The bottom plan view of the second embodiment of the boat is identical to the view shown in FIG. 3 and therefore is not illustrated. The left side of the boat is a mirror image of the right side shown in FIGS. 2 and 7, except that an overflow port, as seen on the port side of the boat in FIGS. 3, 4 and 8, is located about halfway down the hull below the forwardmost chair mounting illustrated in FIG. 1 and below the forwardmost chair illustrated in FIG. 6.

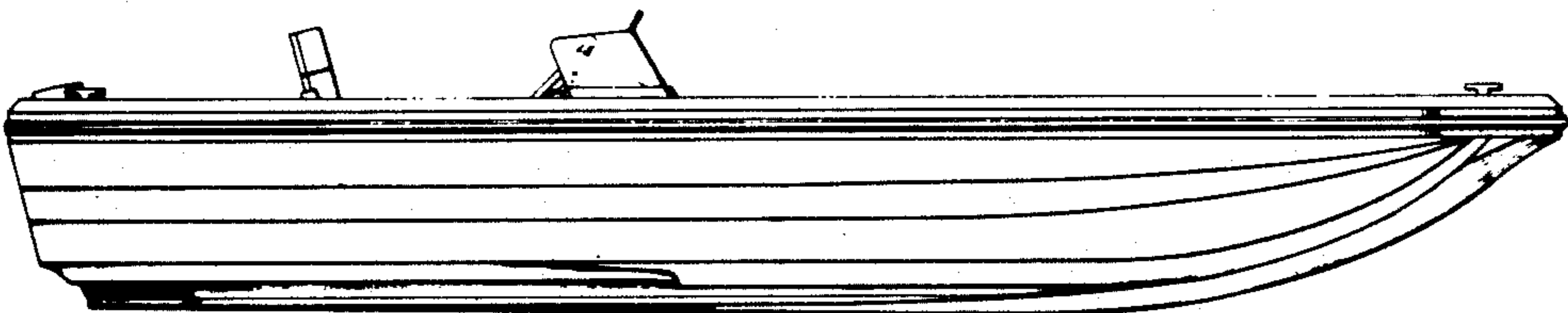
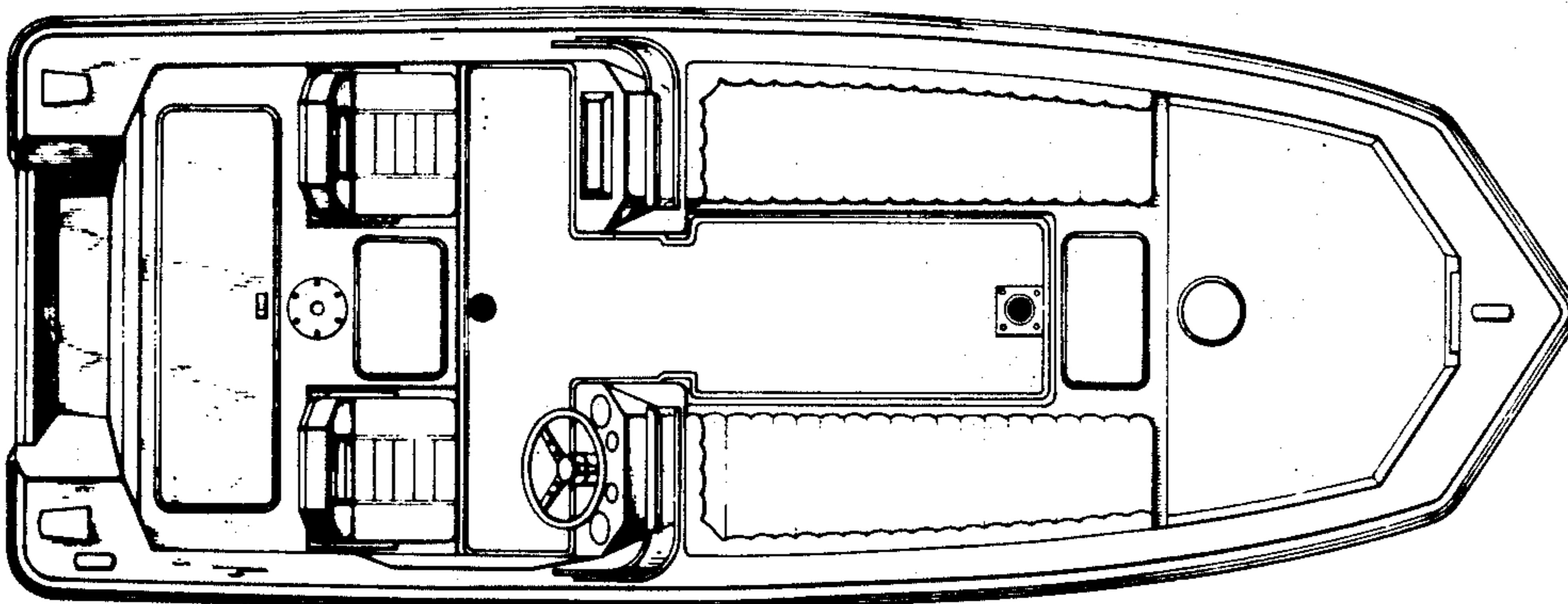

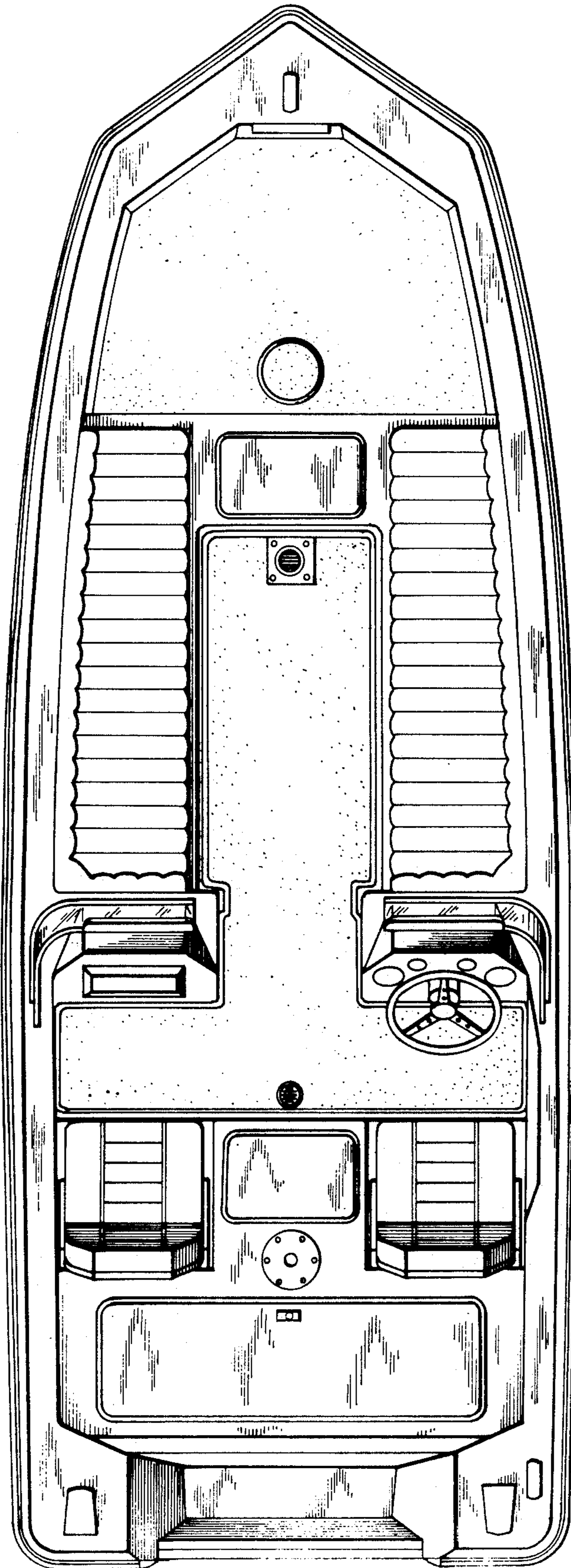

FIG. 1

FIG. 2

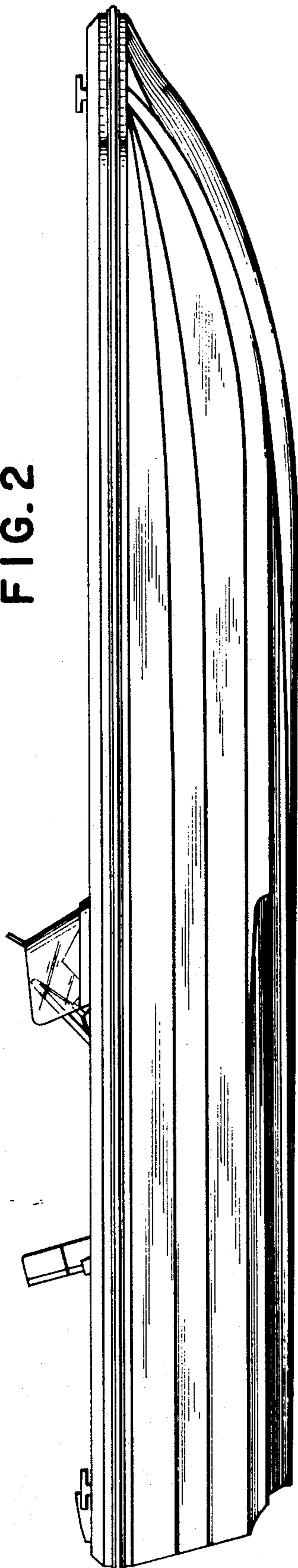
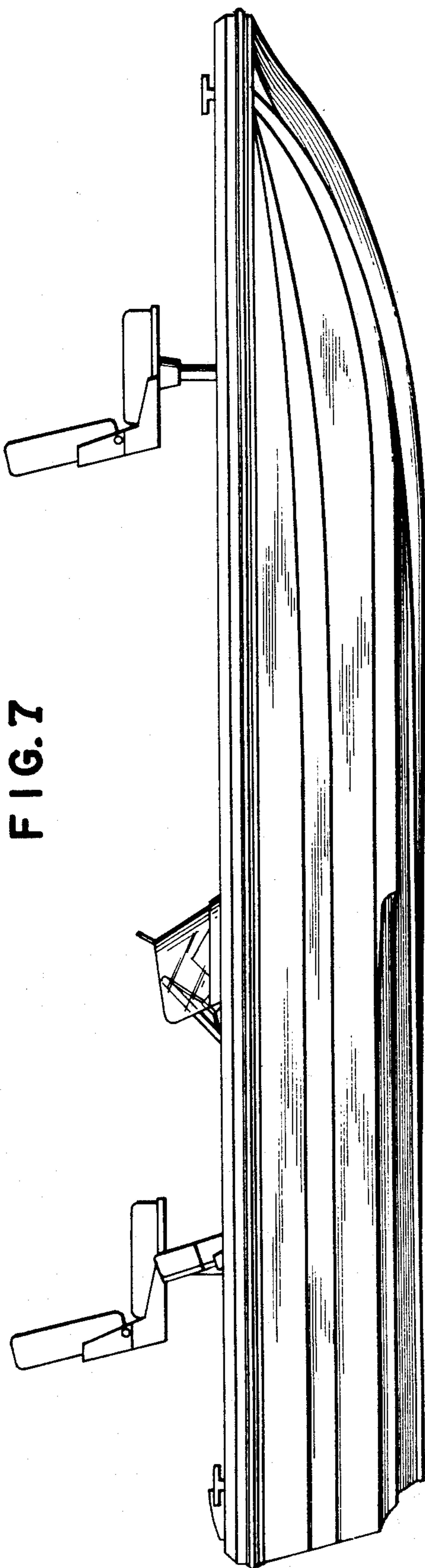

FIG. 7



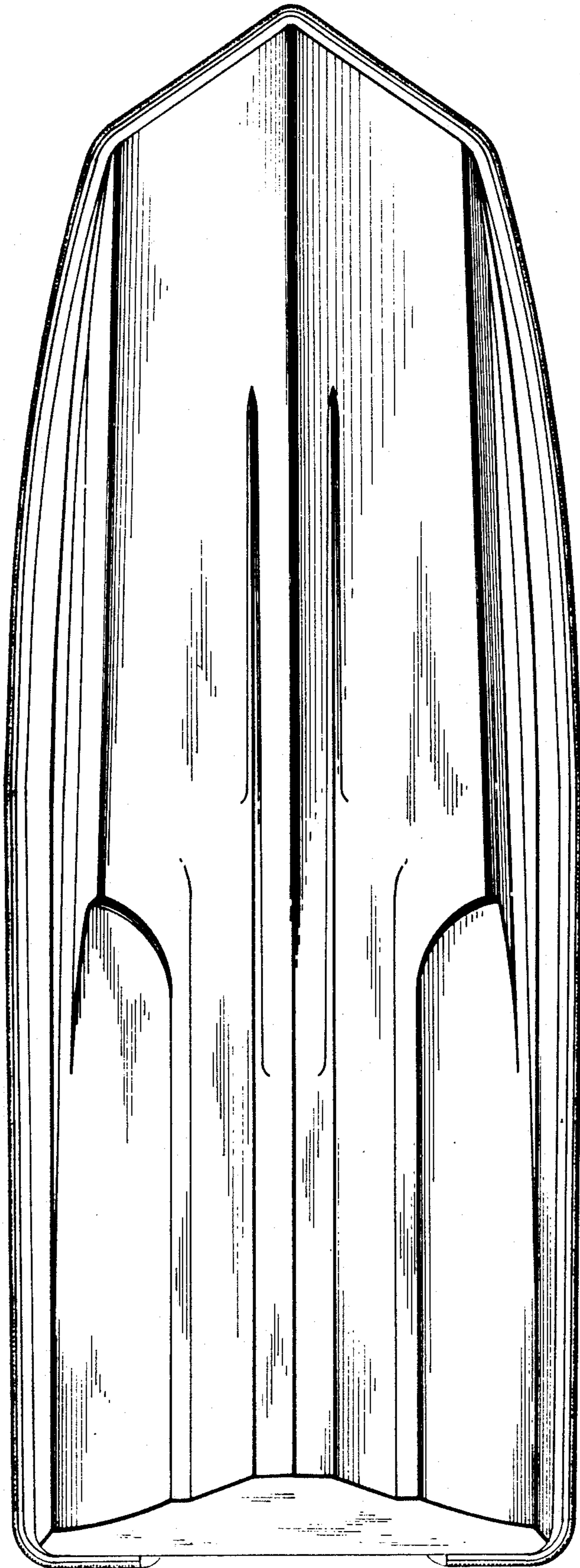

FIG. 3

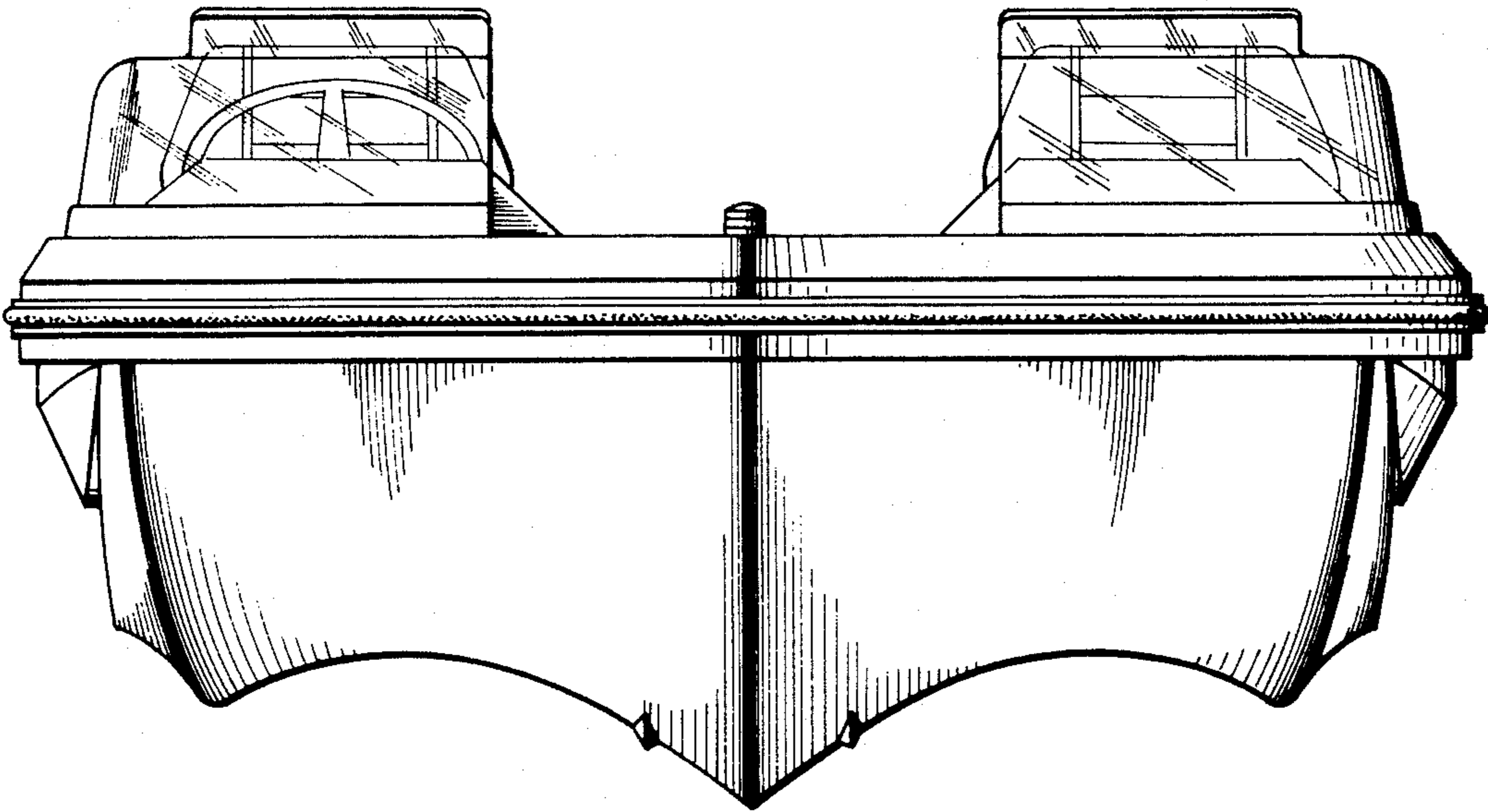

FIG. 4

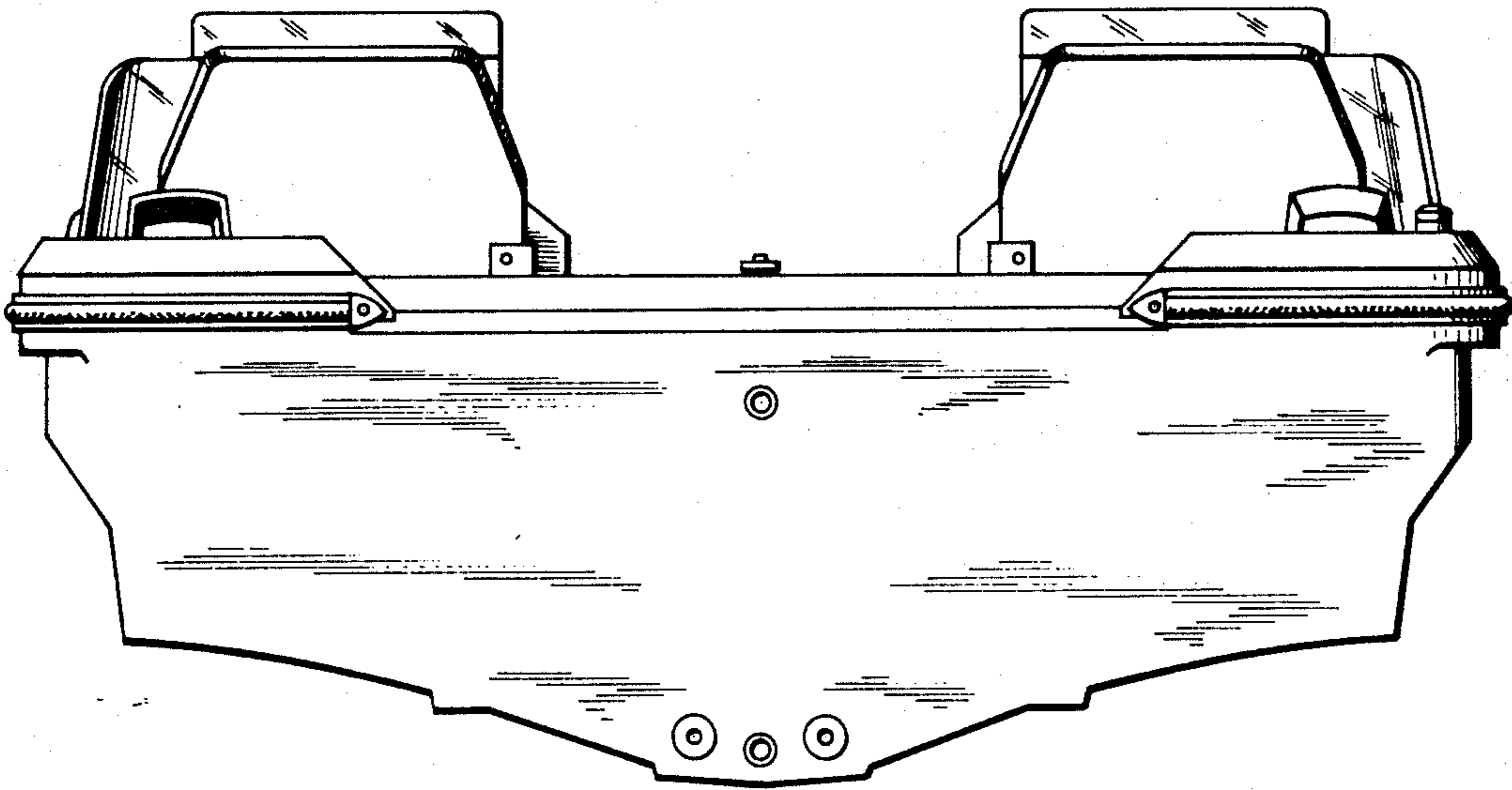

FIG. 5

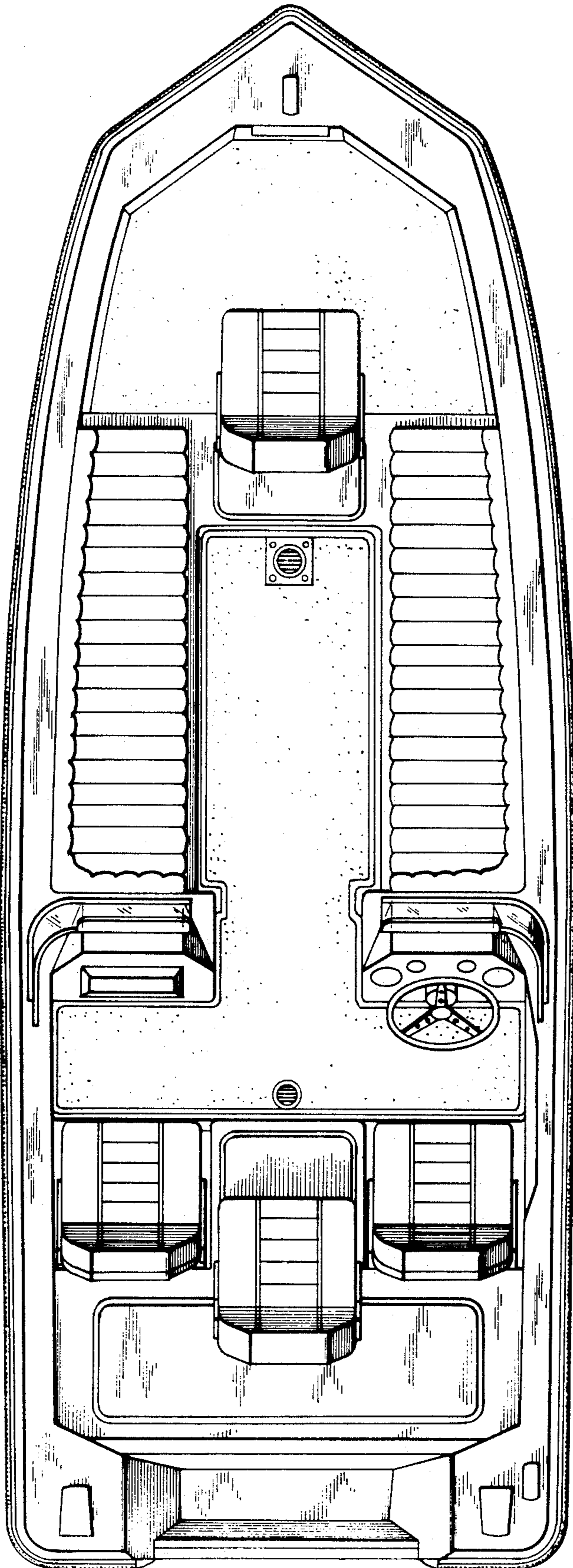

FIG. 6

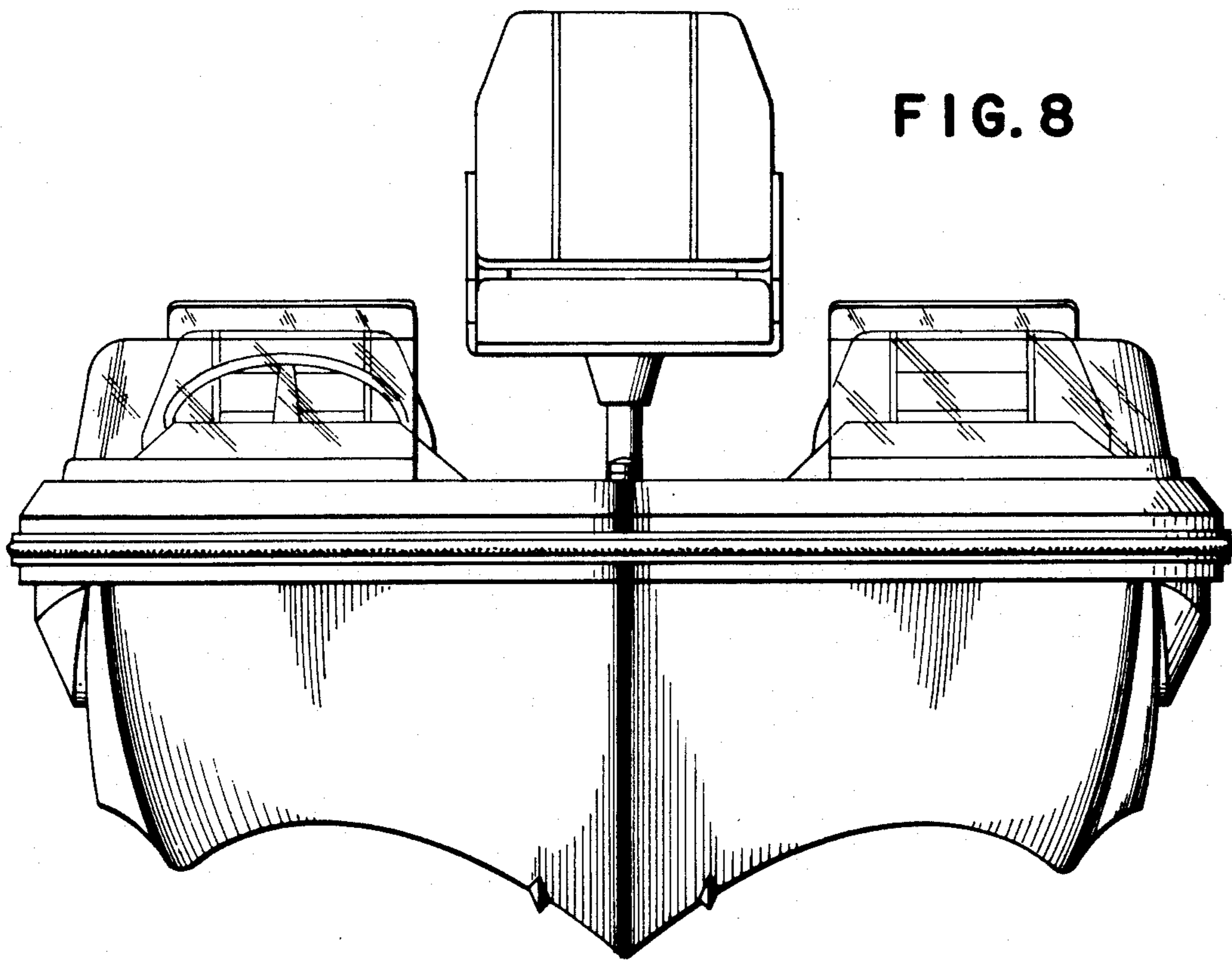

FIG. 8

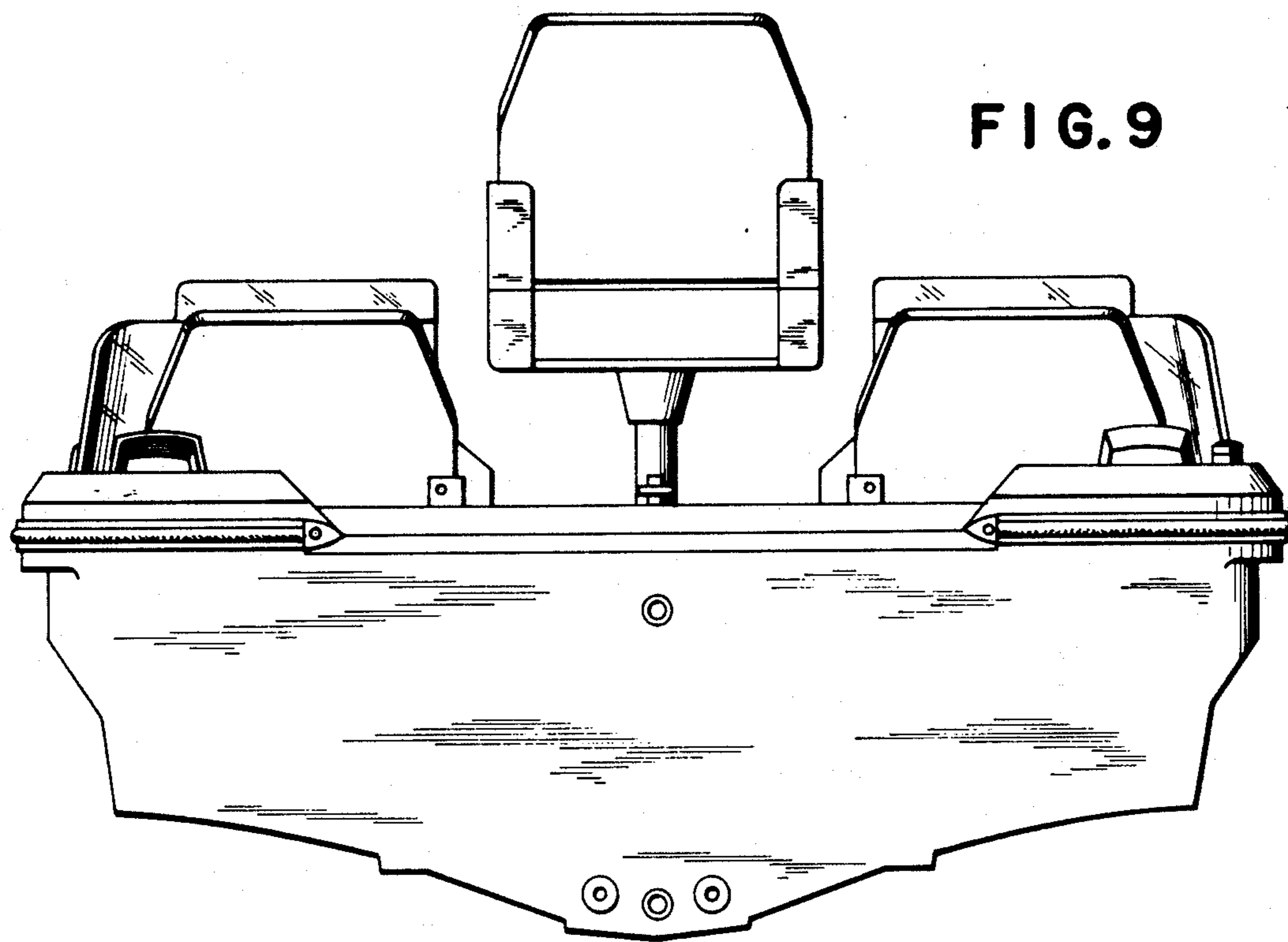

FIG. 9