

[54] PAIR OF AUTOMOBILE HEADLAMP LENSES

[75] Inventor: Carl A. Cameron, Detroit, Mich.

[73] Assignee: Chrysler Corporation, Highland Park, Mich.

[**] Term: 14 Years

[21] Appl. No.: 763,163

[22] Filed: Jan. 27, 1977

[51] Int. Cl. D26-06

[52] U.S. Cl. D48/32 A

[58] Field of Search D48/32 R, 32 A; 362/326-361, 276

[56] References Cited

U.S. PATENT DOCUMENTS

3,818,211	6/1974	Wilfert et al.	362/376
3,883,733	5/1975	Nagel	362/334

OTHER PUBLICATIONS

Washington Post Oldsmobile Advertising Supplement, 9-23-1974, p. 3, omega tail lamp.

Primary Examiner—Susan J. Lucas
Attorney, Agent, or Firm—Gerald P. Dundas

[57] CLAIM

The ornamental design for a pair of automobile headlamp lenses, substantially as shown and described.

DESCRIPTION

FIG. 1 is a perspective view of a pair of automobile headlamp lenses showing my new design; and

FIG. 2 is an enlarged perspective view of one of the lenses of the new design.

FIG. 3 is a greatly enlarged front elevational view thereof;

FIG. 4 is a greatly enlarged side elevational view thereof.

The dotted lines shown in the drawing are for illustrative purposes only.

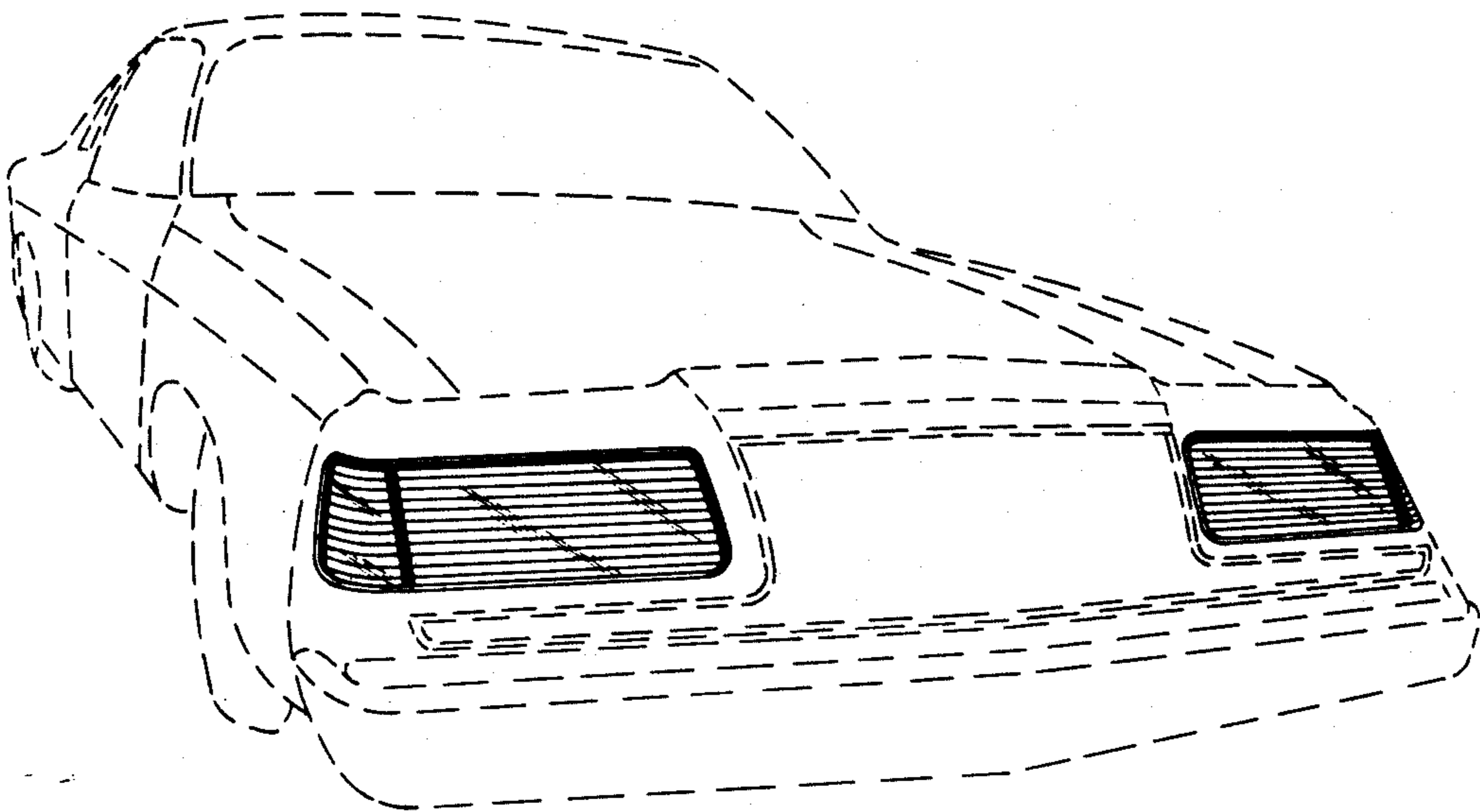

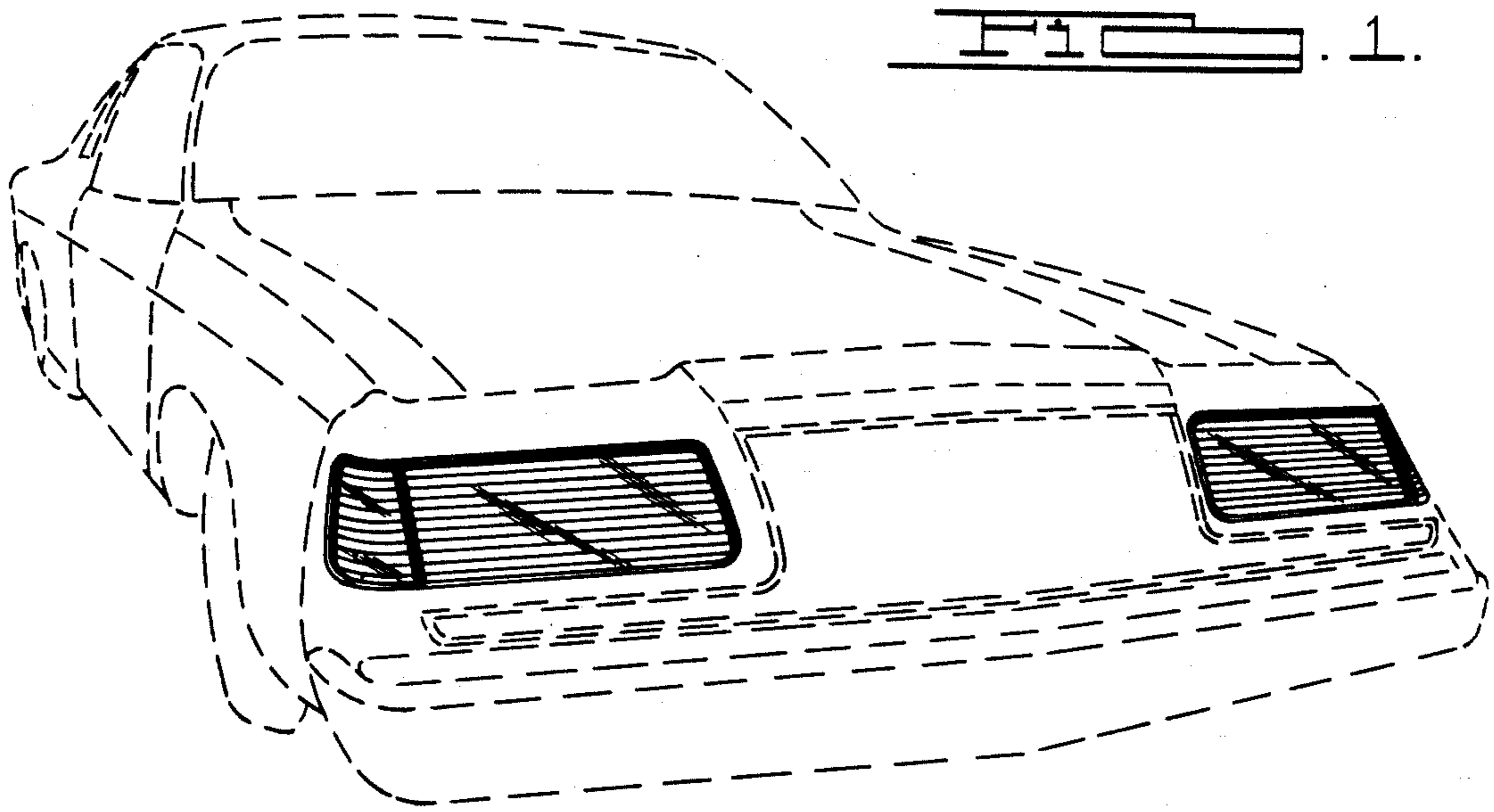

FIG. 1.

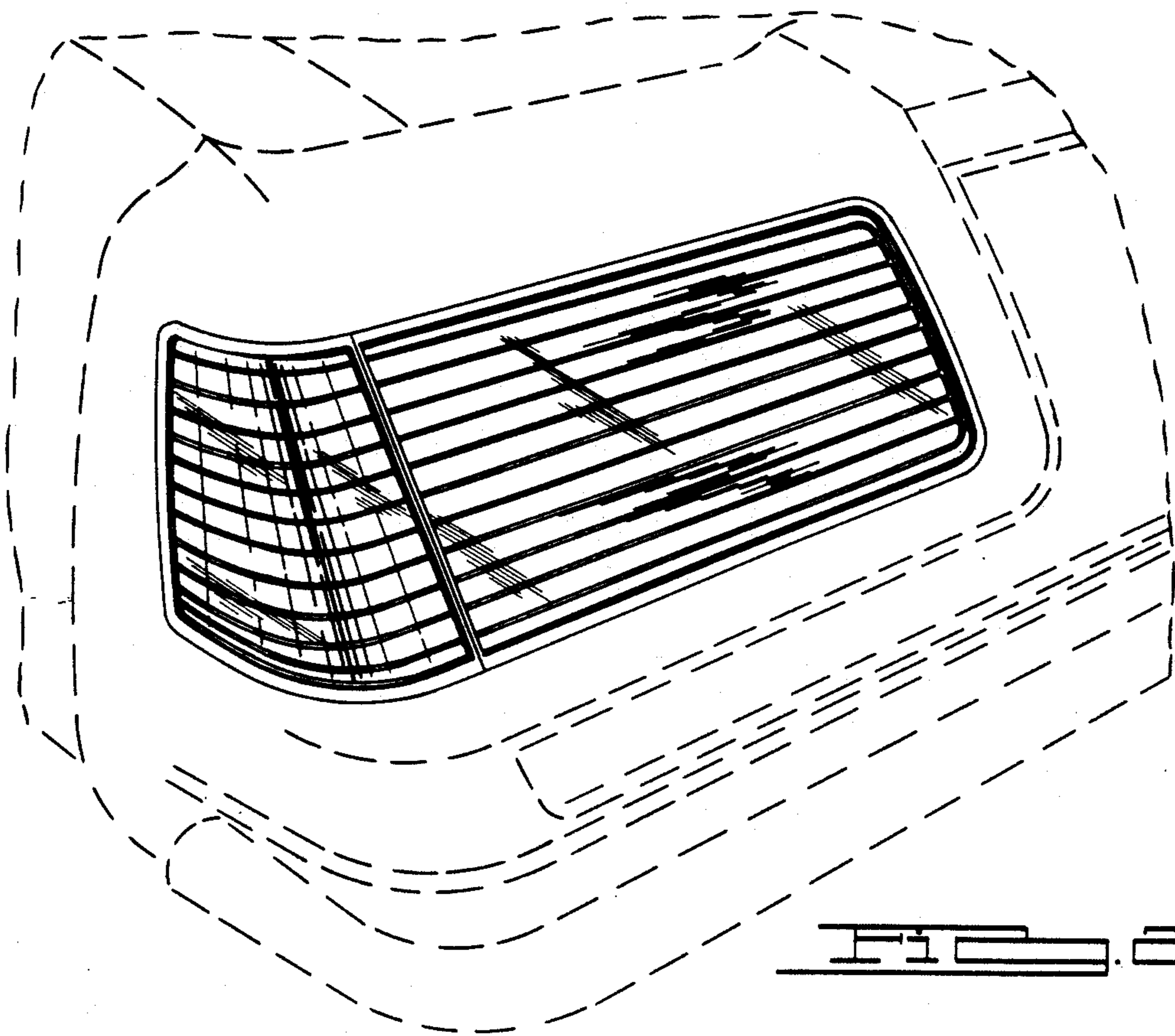

FIG. 2.

FIG. 3.

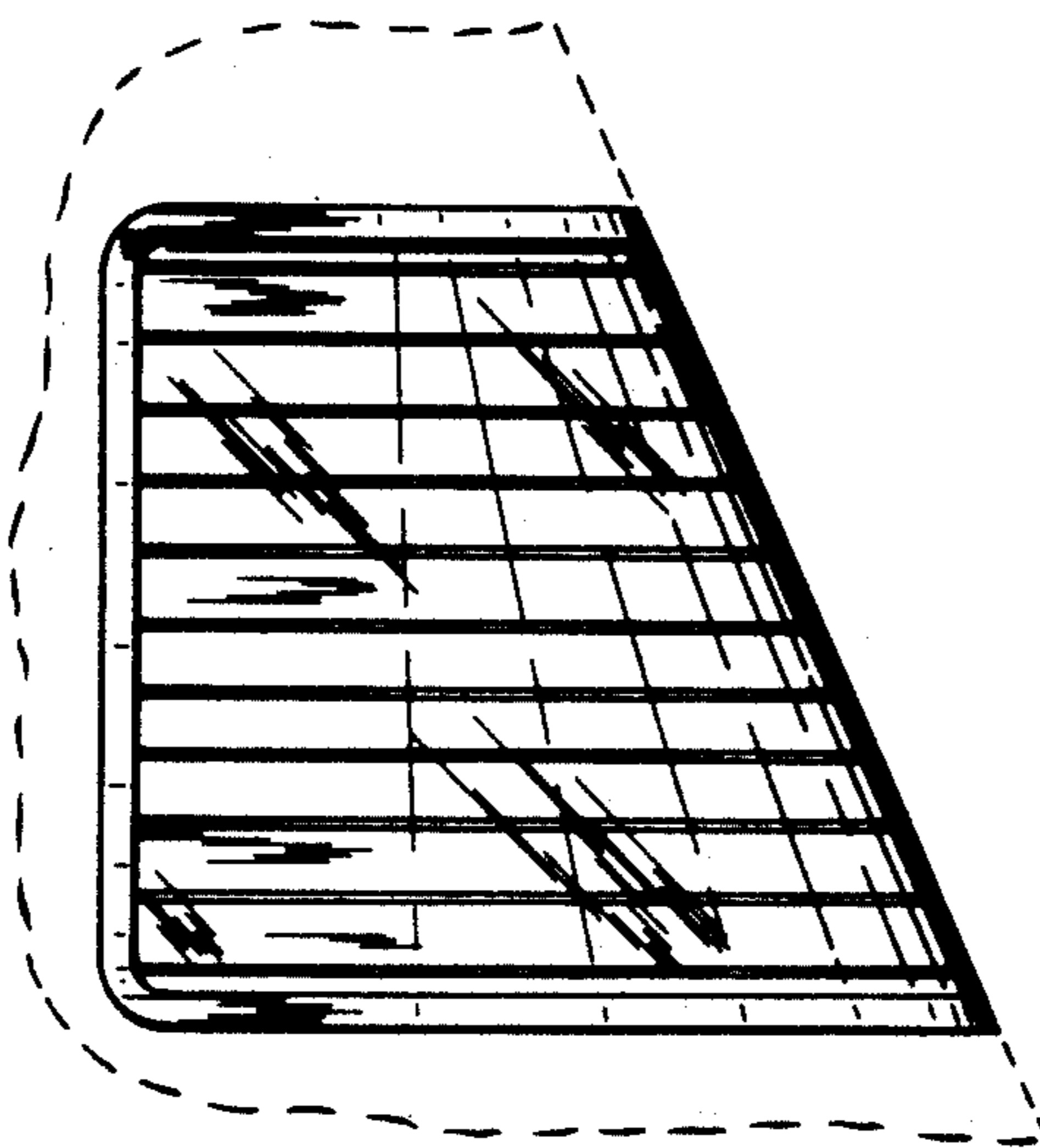

FIG. 4.