

[54] MOTORCYCLE

[76] Inventors: Makoto Hori, 5-8-204, Nishiyamoto-danchi, Wako-shi, Saitama-ken; Hiroshi Nakano, 2-1-5, Kamiigusa, Suginami-ku, Tokyo, both of Japan

[**] Term: 14 Years

[21] Appl. No.: 865,341

[22] Filed: Dec. 28, 1977

[30] Foreign Application Priority Data

Jun. 30, 1977 [JP] Japan 52-25697

[51] Int. Cl. D12-11

[52] U.S. Cl. D12/110

[58] Field of Search D12/110, 111; 180/31, 180/32, 33 R, 33 A, 33 C, 34

[56]

References Cited

U.S. PATENT DOCUMENTS

D. 241,527 9/1976 Kojo D12/110
3,280,932 10/1966 Moulton D12/110

Primary Examiner—James M. Gandy
Attorney, Agent, or Firm—Eric H. Waters

[57]

CLAIM

The ornamental design for a motorcycle, substantially as shown and described.

DESCRIPTION

FIG. 1 is a left side elevational view of a motorcycle showing our new design;
FIG. 2 is a top plan view thereof;
FIG. 3 is a front perspective view thereof;
FIG. 4 is a right side elevational view thereof;
FIG. 5 is a rear perspective view thereof; and
FIG. 6 is a bottom plan view thereof.

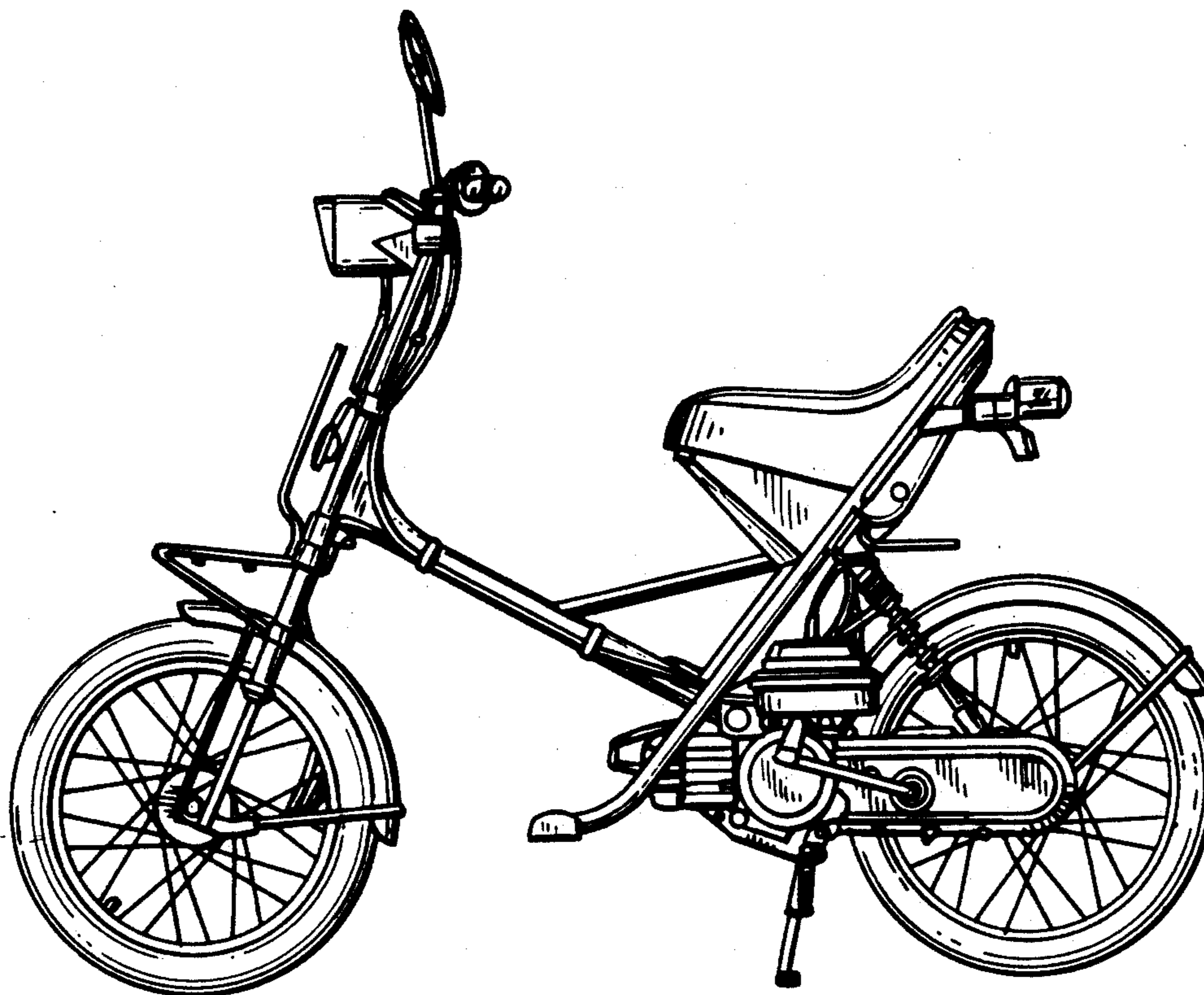

FIG. 1

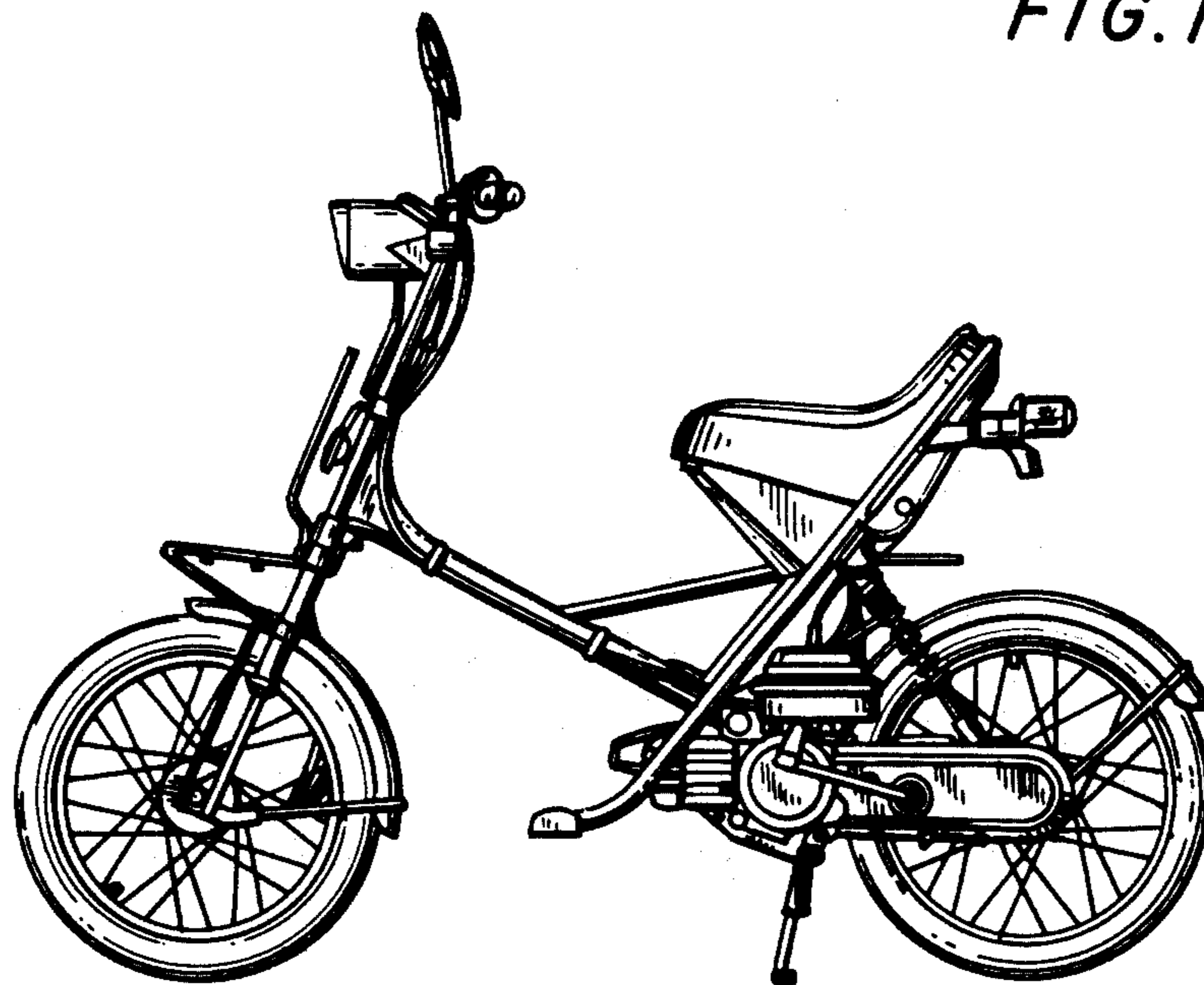

FIG. 2

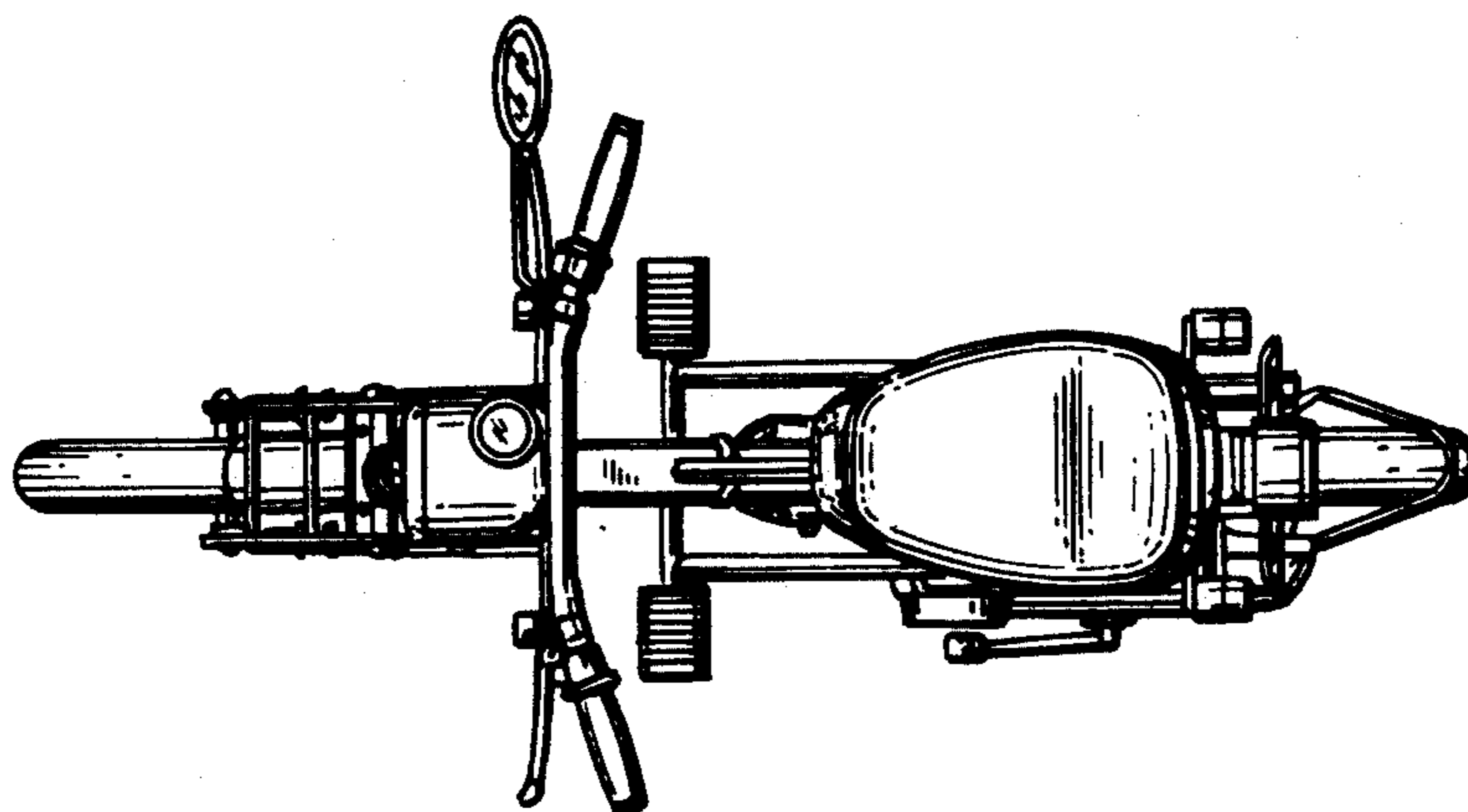

FIG. 3

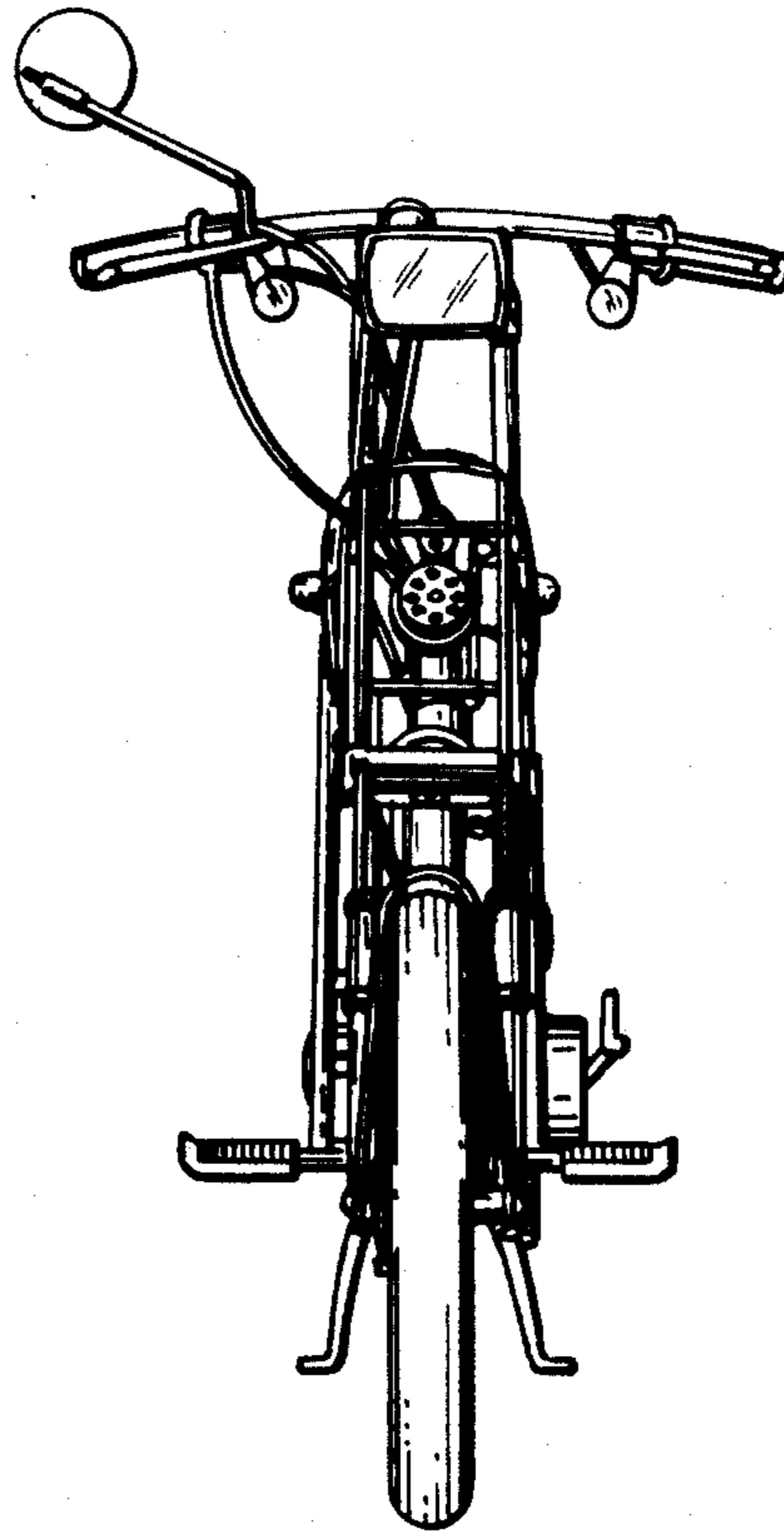

FIG. 4

