

[54] EXHAUST MANIFOLD CLAMP

3,596,898 8/1971 Hilburn ..... D8/72 X

[76] Inventor: Richard Uyeda, 416 E. Prairie St., Marengo, Ill. 60152

FOREIGN PATENT DOCUMENTS

1334247 6/1963 France ..... 24/263 A

[\*\*] Term: 14 Years

Primary Examiner—A. Hugo Word  
Attorney, Agent, or Firm—Francis X. Lo Jacono, Sr.

[21] Appl. No.: 797,560

[57] CLAIM

[22] Filed: May 16, 1977

The ornamental design for an exhaust manifold clamp, as shown.

[51] Int. Cl. .... D8—08

[52] U.S. Cl. .... D8/394; D8/73

[58] Field of Search ..... 24/243 R, 275, 279, 24/248 SA, 263 A; D8/72, 73, 394, 396; 269/205, 240, 243, 246, 249

DESCRIPTION

FIG. 1 is a perspective view of an exhaust manifold clamp, showing my new design;

FIG. 2 is a side-elevational view thereof;

FIG. 3 is a rear-elevational view thereof;

FIG. 4 is a cross-sectional view taken along line 4—4 of FIG. 1;

FIG. 5 is another cross-sectional view taken along line 5—5 of FIG. 1; and

FIG. 6 is a bottom plan view thereof.

[56] References Cited  
U.S. PATENT DOCUMENTS

D. 231,082	4/1974	Lewis	.....	D8/394
2,682,694	7/1954	Kempkes	.....	24/263 A
3,033,559	5/1962	Lindholm	.....	24/263 A

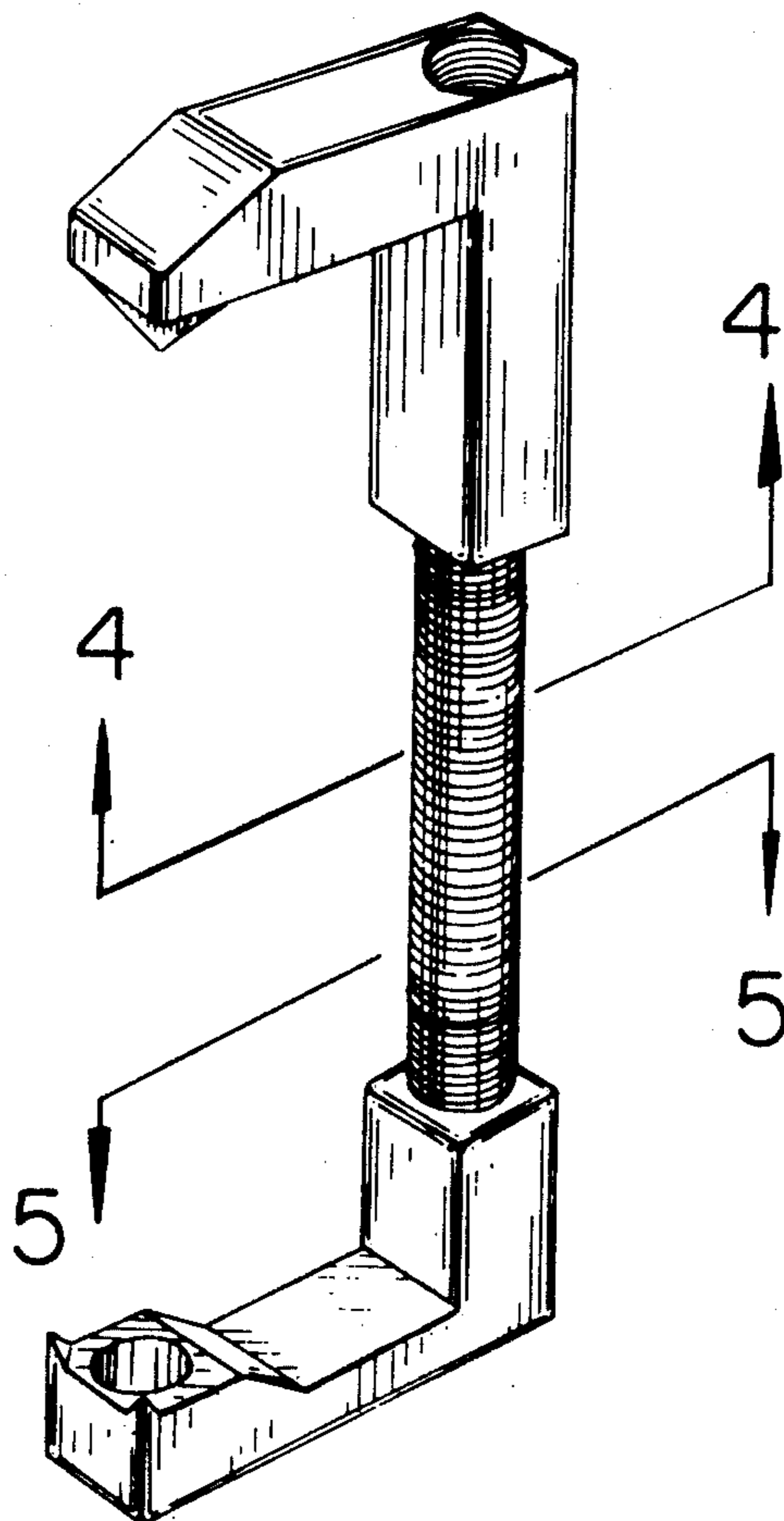

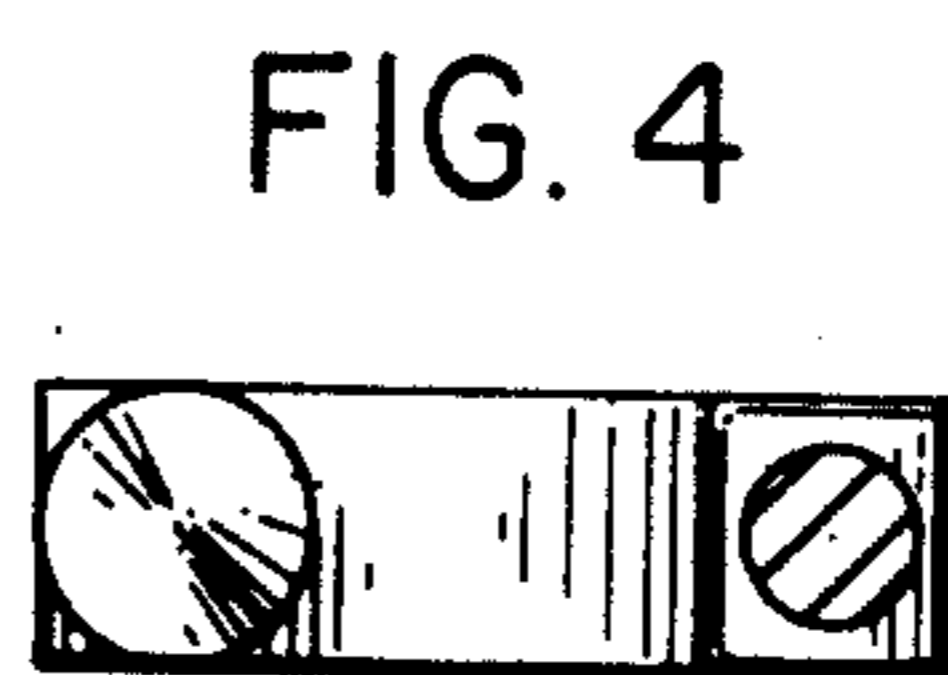
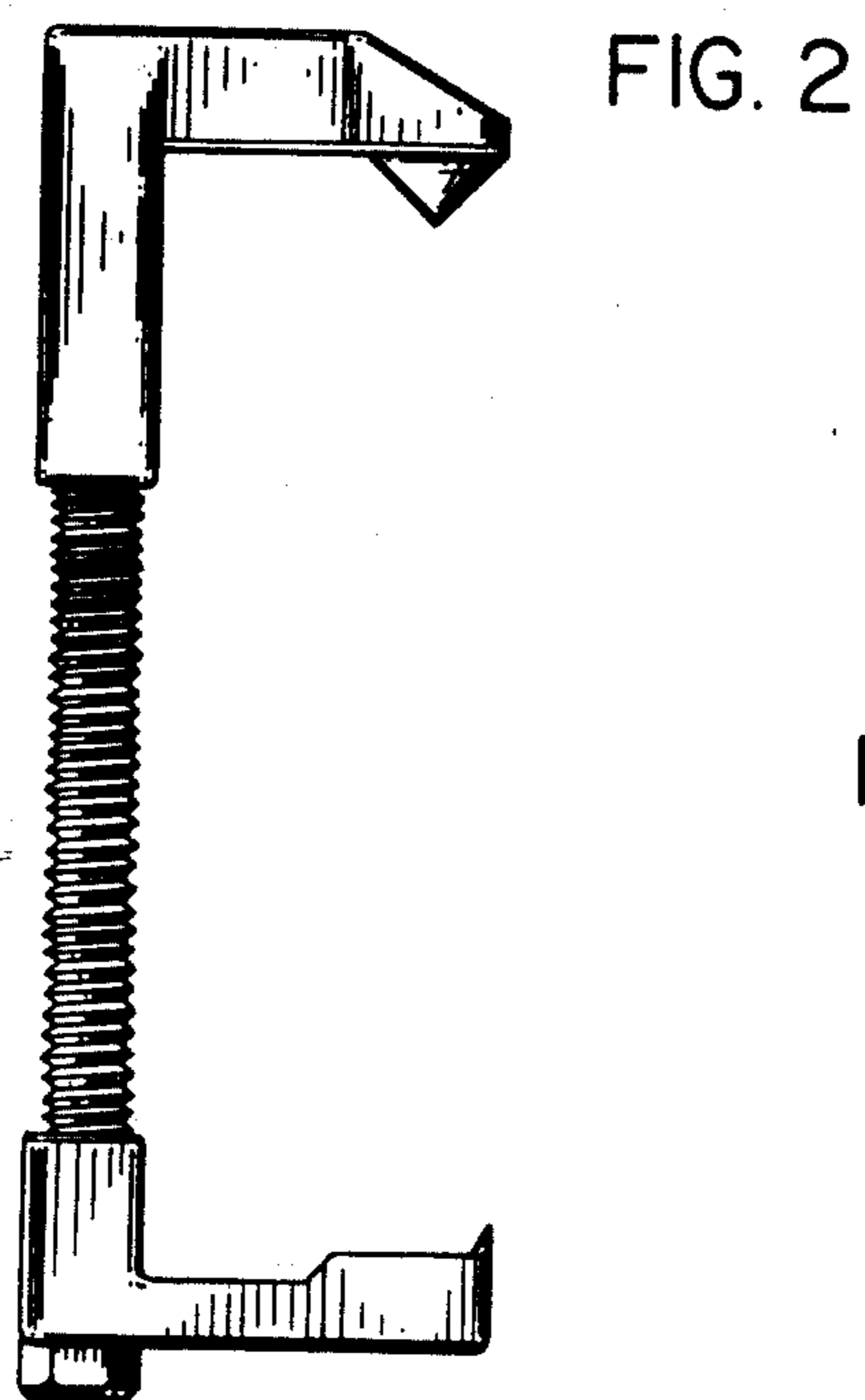
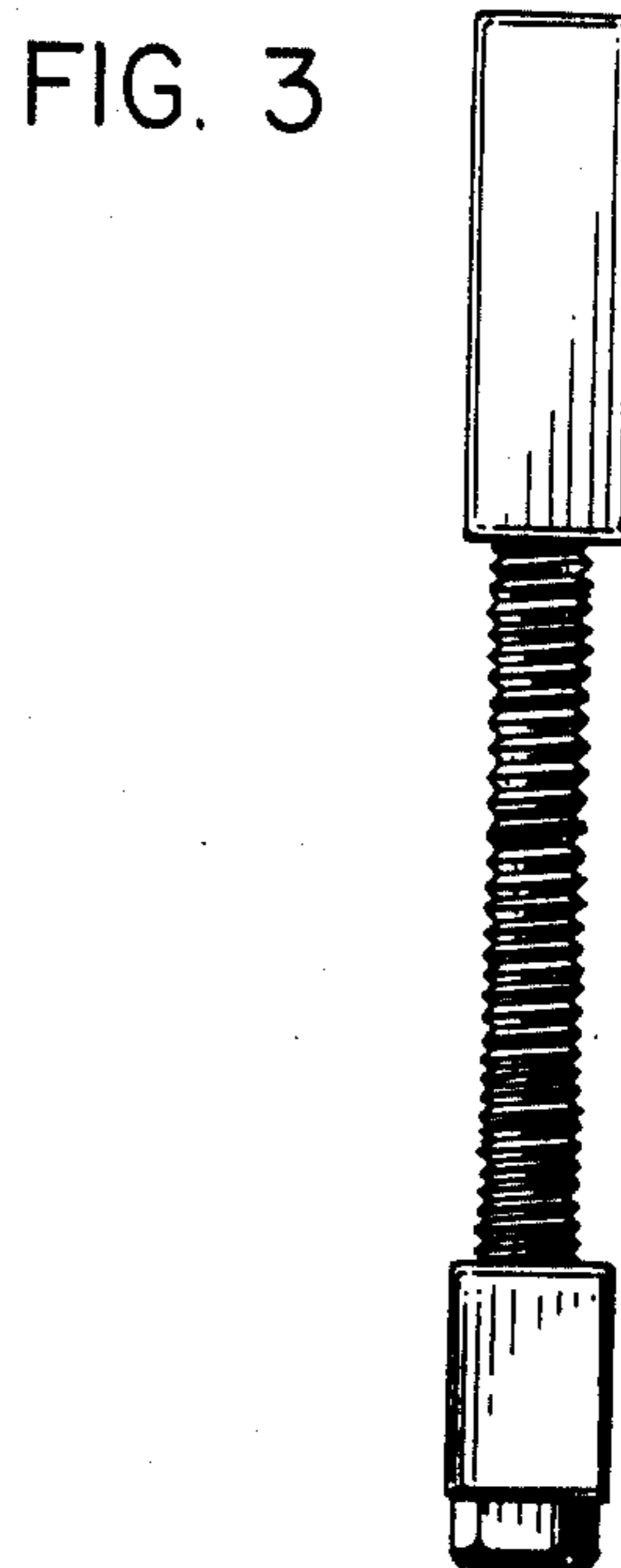
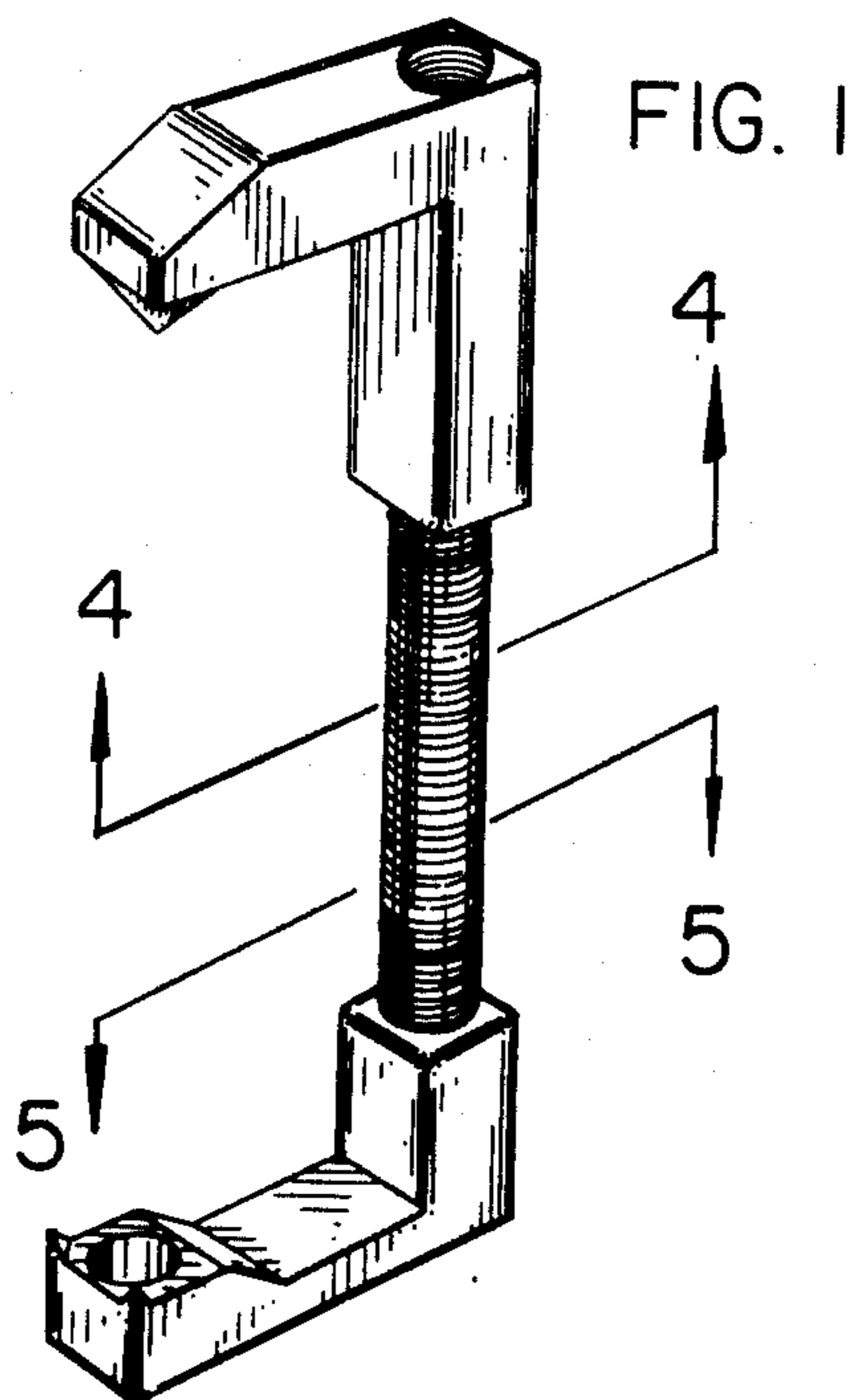

FIG. 6