

[54] INTERNAL COMBUSTION ENGINE

[76] Inventors: Buford J. Schramm, 1330 E. Fremont Dr., Tempe, Ariz. 85281; Robert G. Everts, 2301 W. Colt Rd., Chandler, Ariz. 85224

[\*\*] Term: 14 Years

[21] Appl. No.: 722,078

[22] Filed: Sep. 10, 1976

[51] Int. Cl. .... D15-01

[52] U.S. Cl. .... D15/3

[58] Field of Search ..... D15/1-4; 123/56 R, 56 A, 56 AA, 56 AC, 41.72, 41.74, 41.82, 41.83, 41.69

[56] References Cited

U.S. PATENT DOCUMENTS

3,545,414 12/1970 Thompson ..... 123/56 B

OTHER PUBLICATIONS

Flight International, 7/19/73, p. 99, Internal Combustion Engine, center left side of page.

Primary Examiner—James M. Gandy  
Attorney, Agent, or Firm—Donald D. Mon

[57] CLAIM

The ornamental design for an internal combustion engine, as shown.

DESCRIPTION

FIG. 1 is a top perspective view of an internal combustion engine showing our new design with the end of the exhaust pipe broken away for convenience of illustration;

FIG. 2 is a front perspective view thereof;

FIG. 3 is a bottom perspective view thereof;

FIG. 4 is a rear perspective view thereof;

FIG. 5 is a left side perspective view thereof, it being understood that the right side is substantially a mirror image of the left side shown herein; and

FIG. 6 is a top, front perspective view thereof.

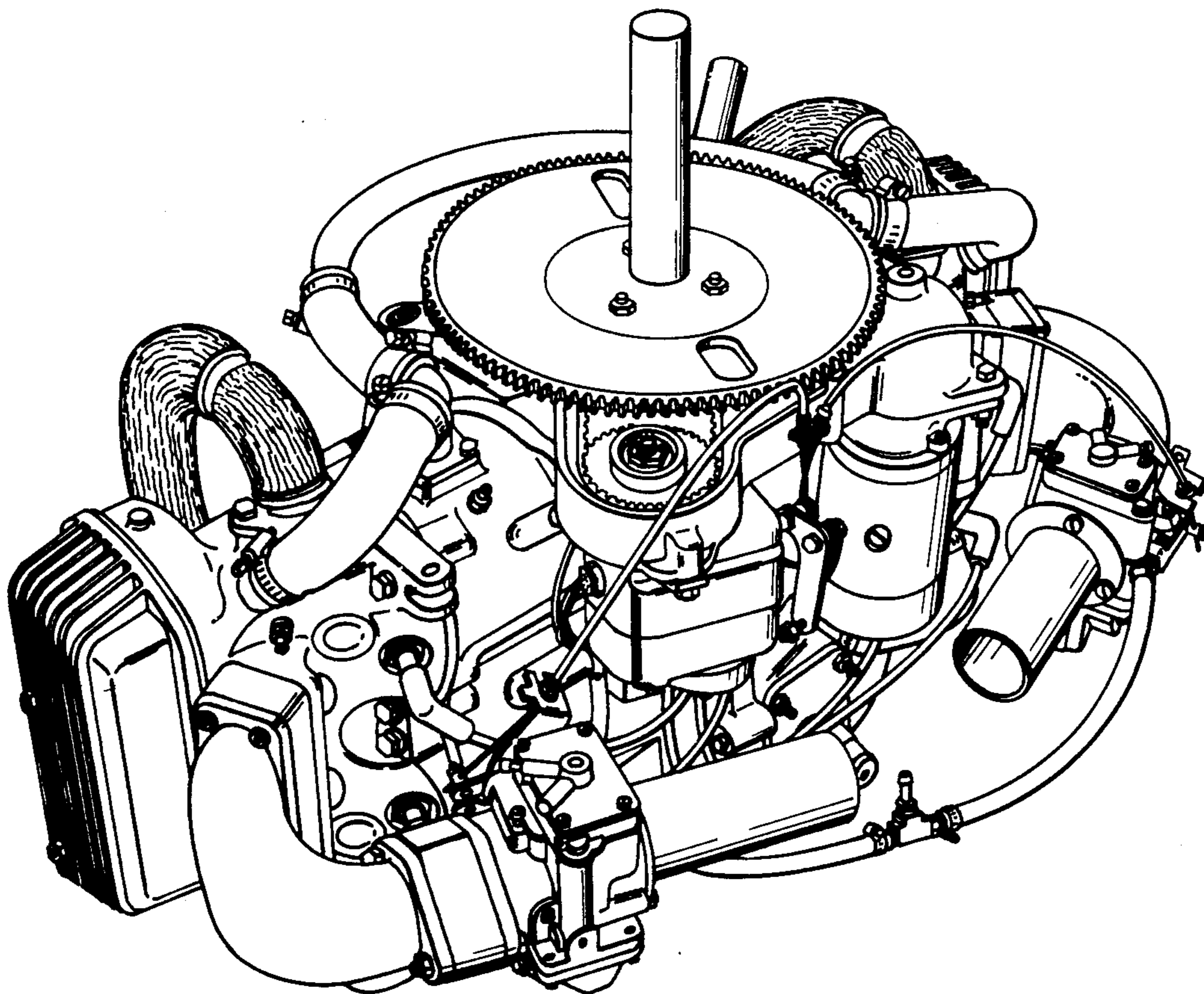

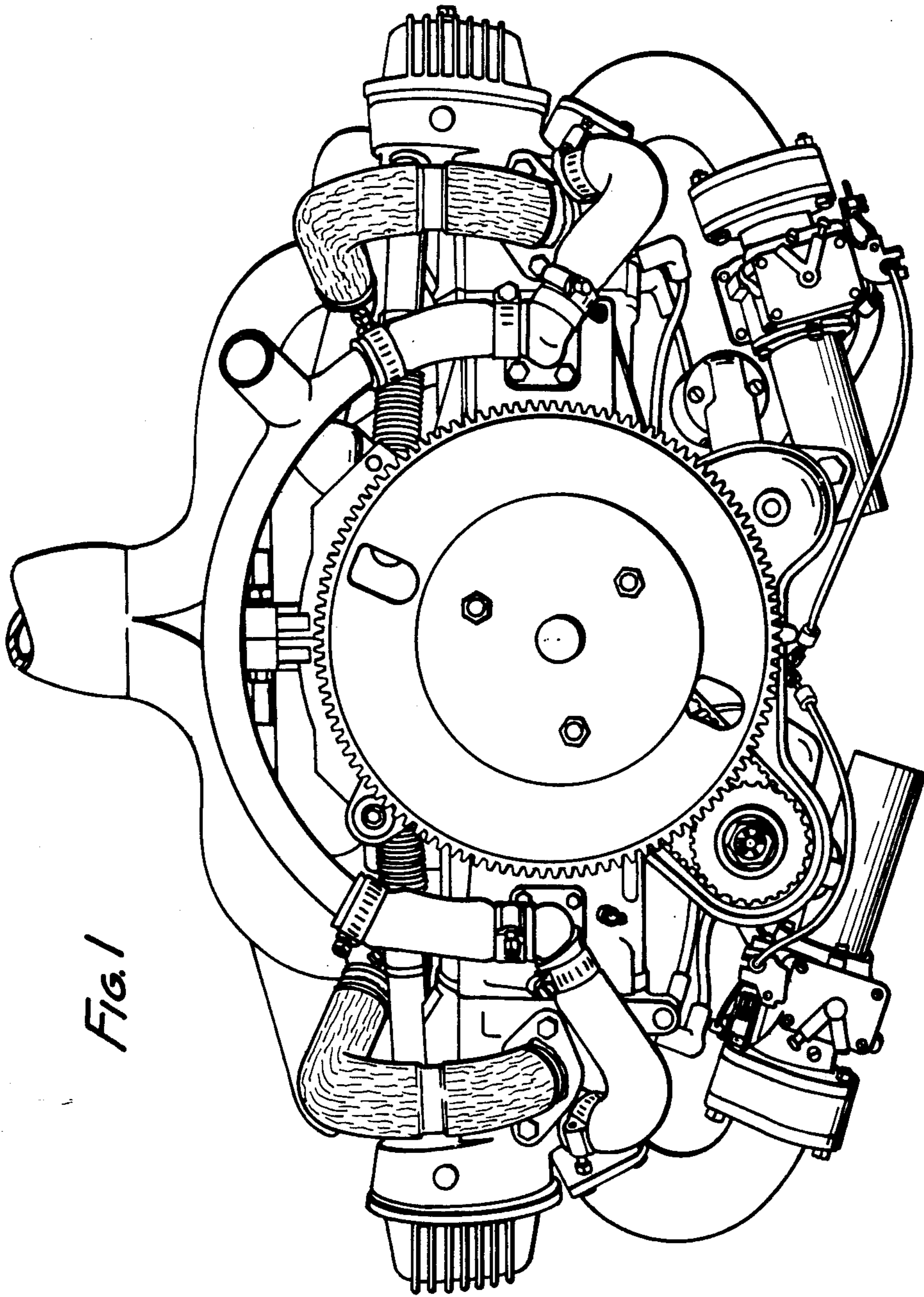

*Fig. 1*



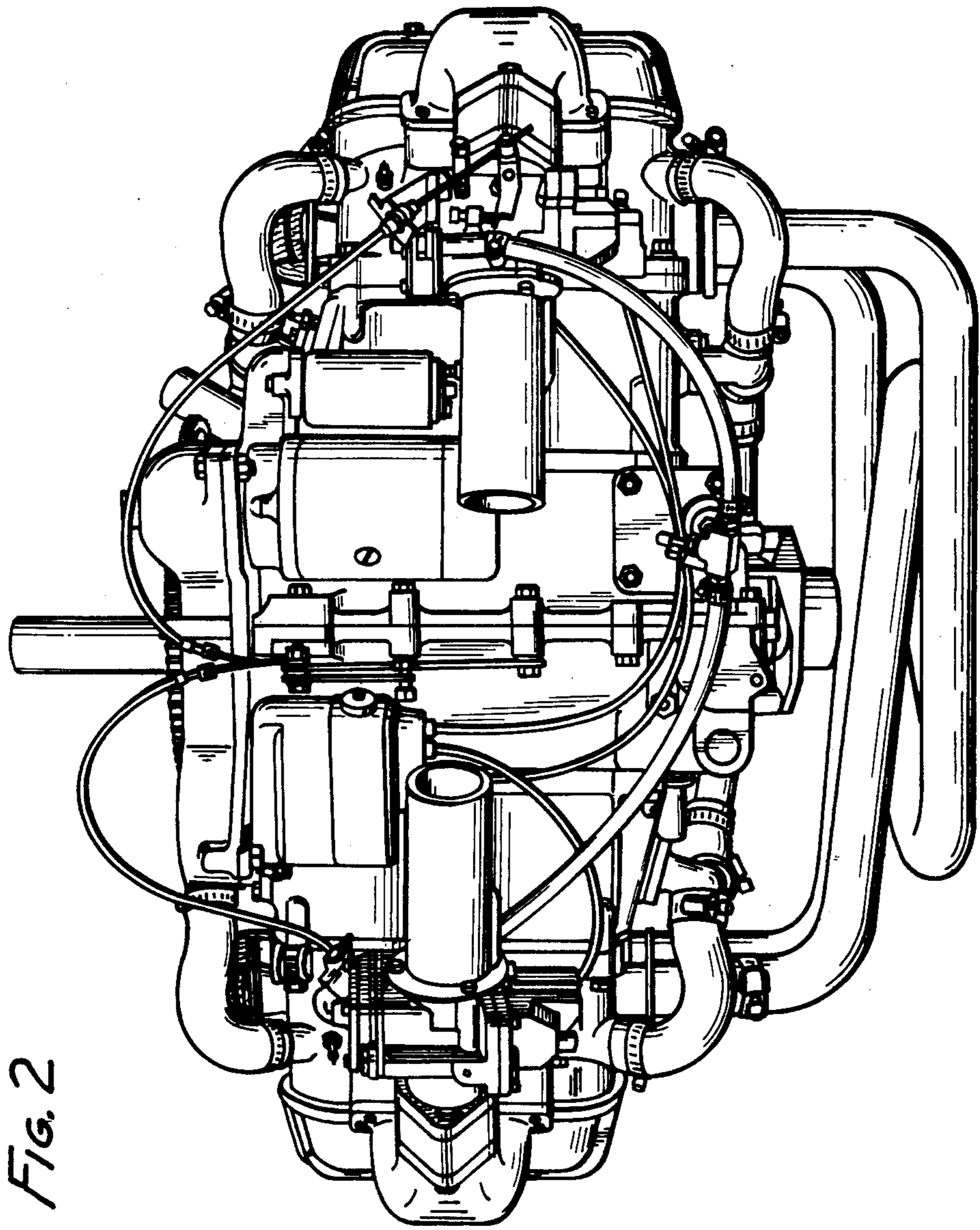

FIG. 2

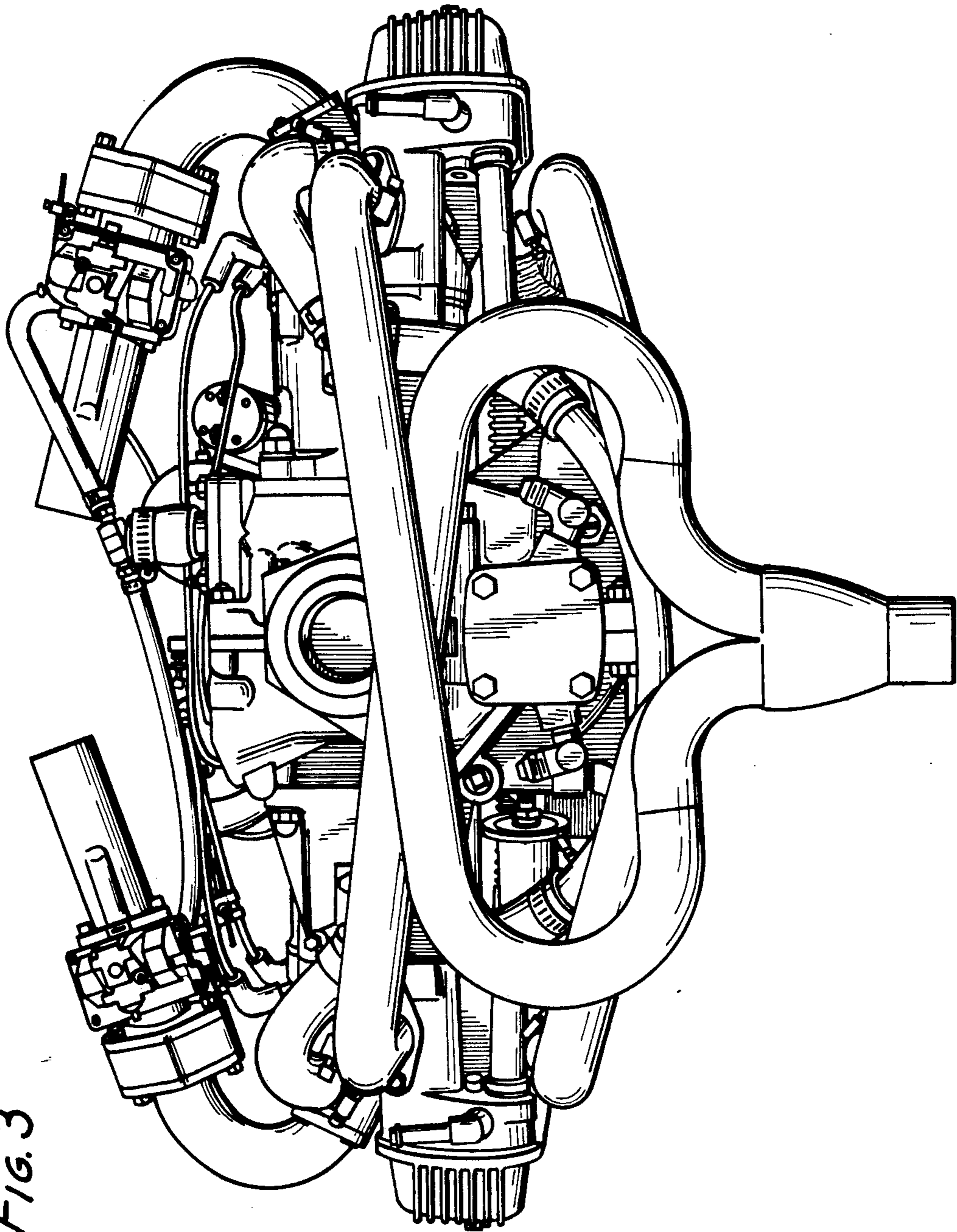
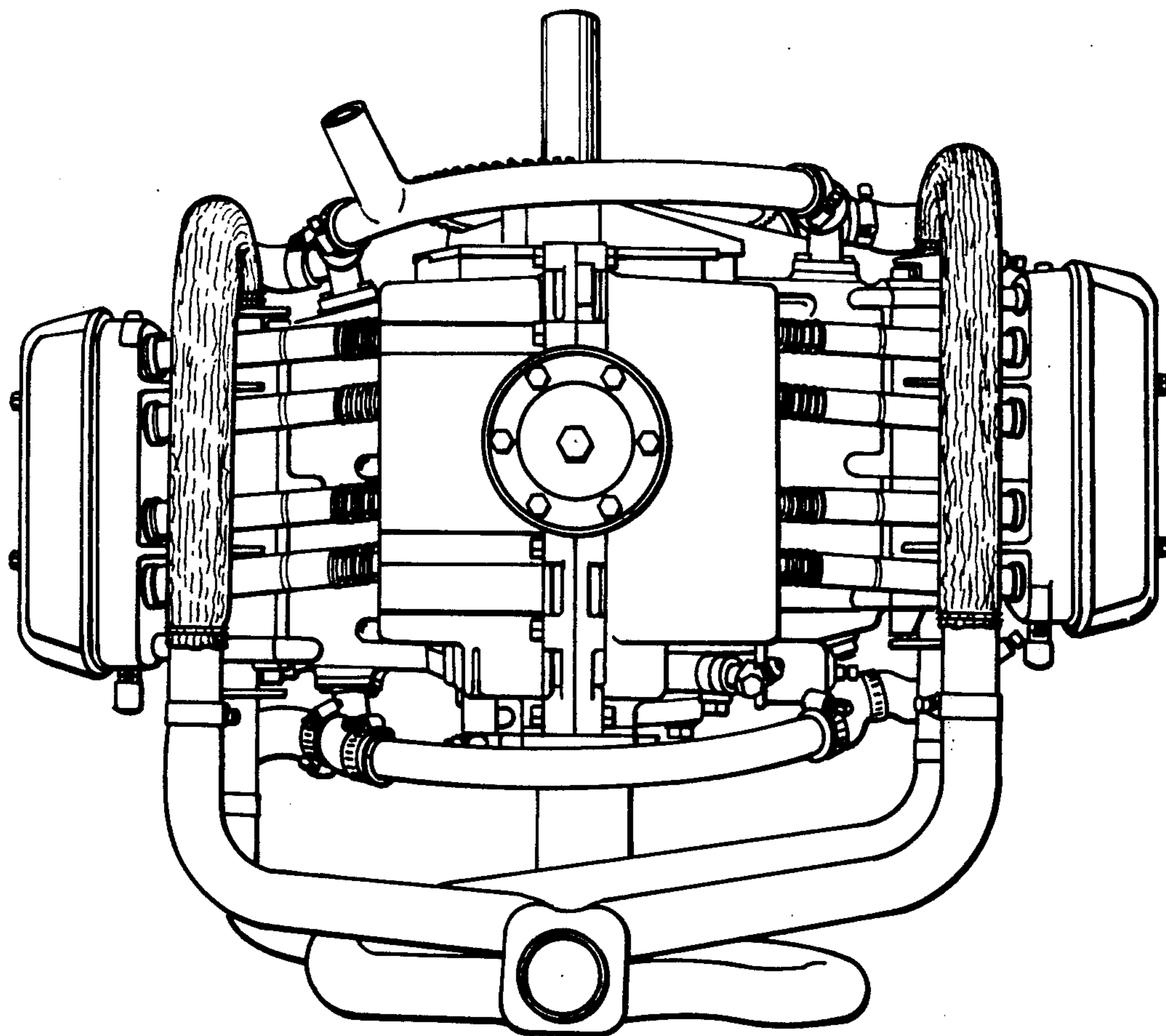
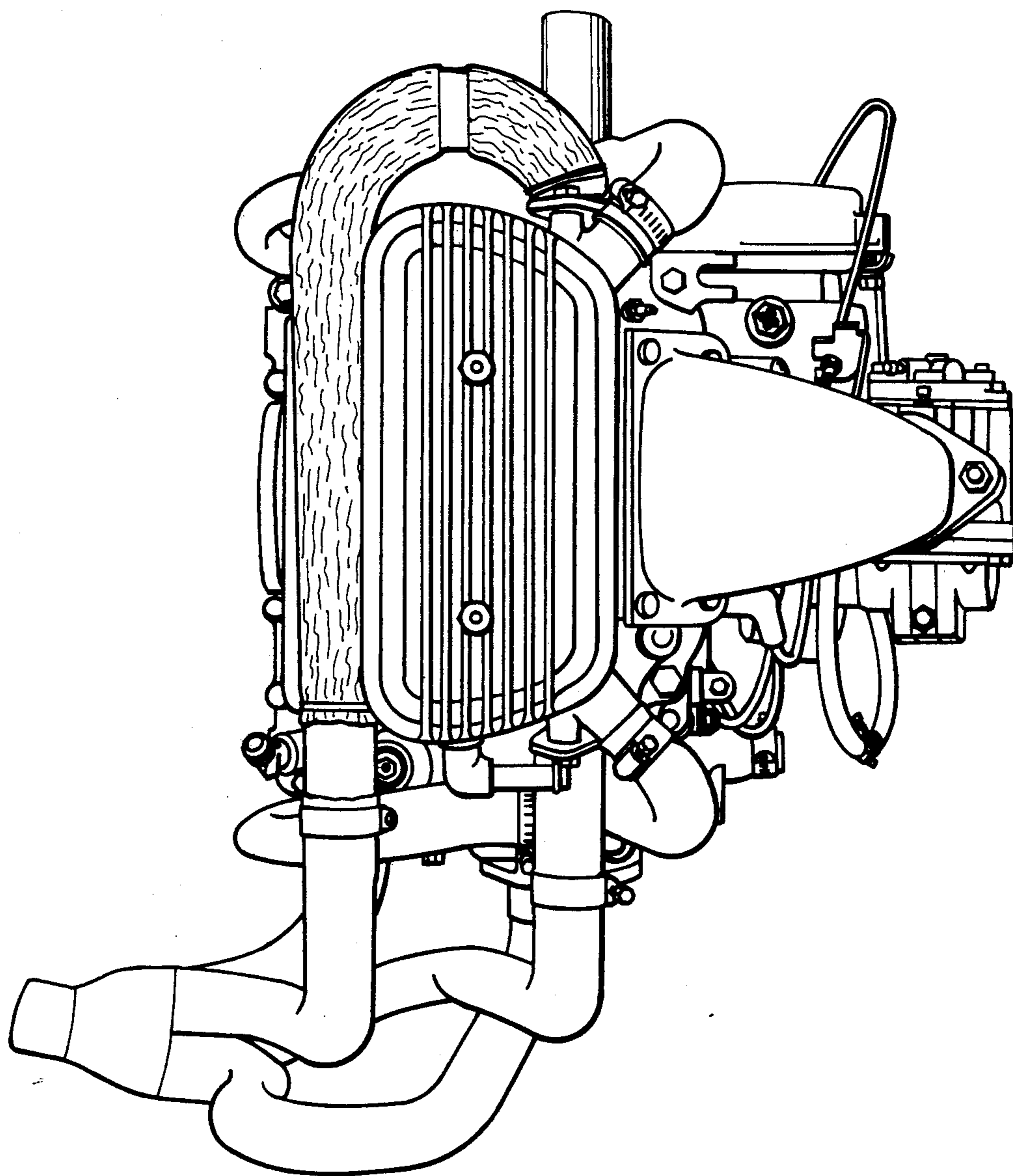

FIG. 3

*FIG. 4*



*FIG. 5*





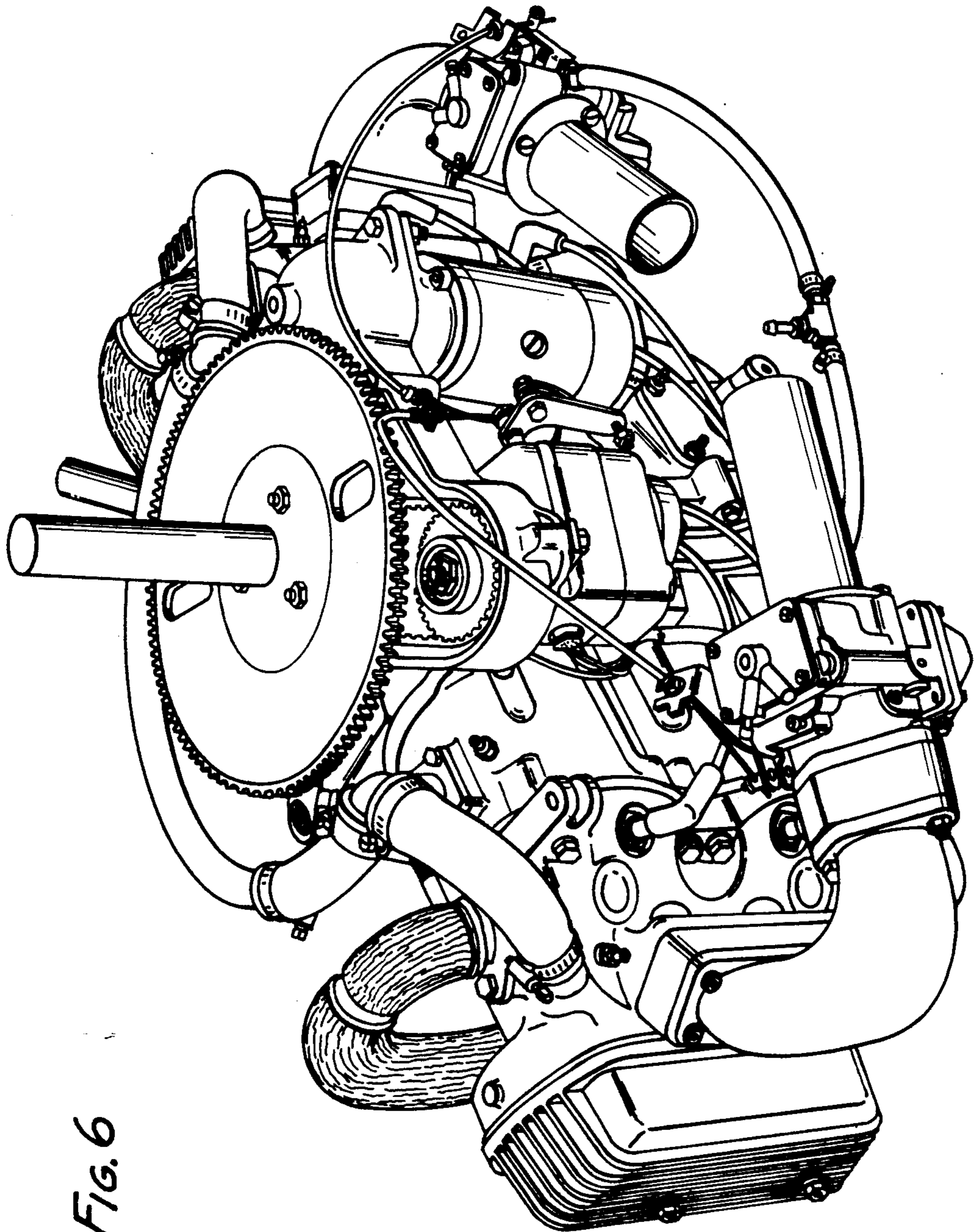

FIG. 6