

[54] AUTOMOTIVE TURN SIGNAL SWITCH

[75] Inventors: Edward J. Nitsch, Camillus; Alan W. Brownlie, Skaneateles; Kent S. Jones, Syracuse, all of N.Y.

[73] Assignee: R. E. Dietz Company, Syracuse, N.Y.

[\*\*] Term: 14 Years

[21] Appl. No.: 818,972

[22] Filed: Jul. 25, 1977

[51] Int. Cl. .... D13-03

[52] U.S. Cl. .... D13/37

[58] Field of Search ..... D13/12, 32, 35, 37, D13/38; 200/5 R, 5 A, 6 R, 4 R, 56 R, 61.27

[56] References Cited

U.S. PATENT DOCUMENTS

1,653,517 12/1927 Smith ..... 200/61.27 X

2,230,891 2/1941 Meyerhoefer ..... 200/6 R  
2,812,396 11/1957 Hollins ..... 200/61.27 X

FOREIGN PATENT DOCUMENTS

2309685 9/1973 Fed. Rep. of Germany ..... 200/61.27

Primary Examiner—Susan J. Lucas  
Attorney, Agent, or Firm—Richard Von K. Bruns

[57] CLAIM

The ornamental design for an automotive turn signal switch, as shown and described.

DESCRIPTION

FIG. 1 is a front elevation of an automotive turn signal switch embodying our new design, the rear elevation being a mirror image thereof;  
FIG. 2 is a top plan view thereof;  
FIG. 3 is a bottom plan view thereof;  
FIG. 4 is a left side elevation thereof; and  
FIG. 5 is a right side elevation thereof.

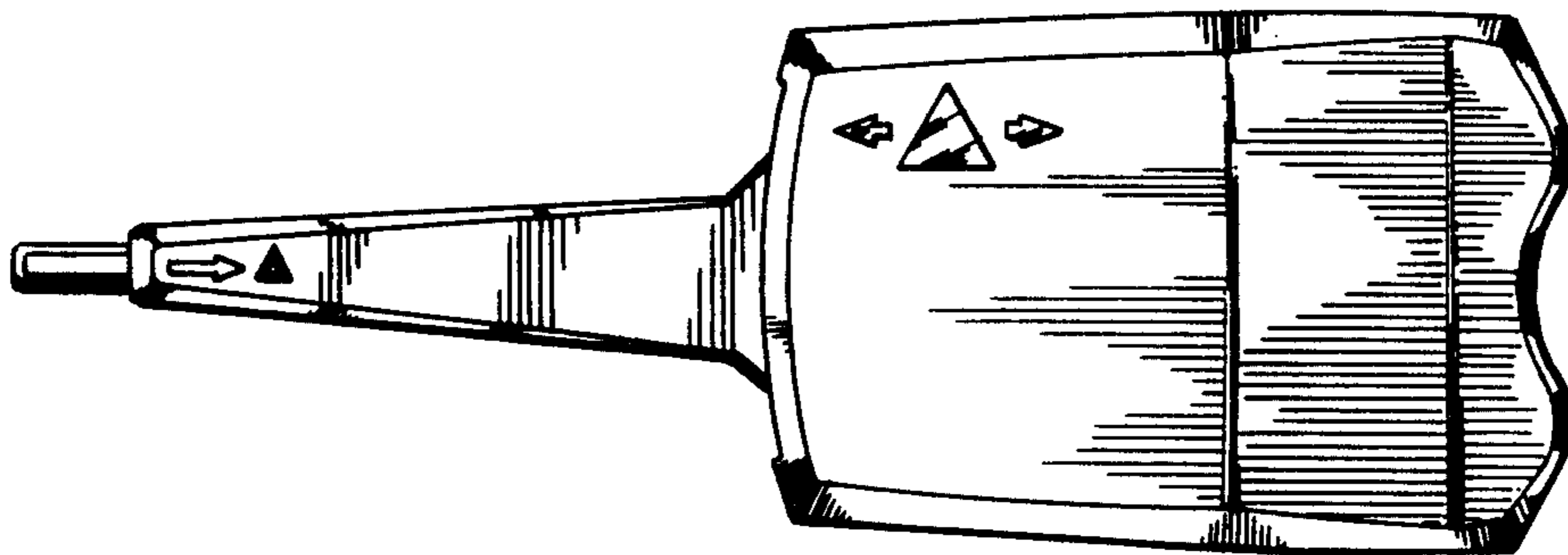

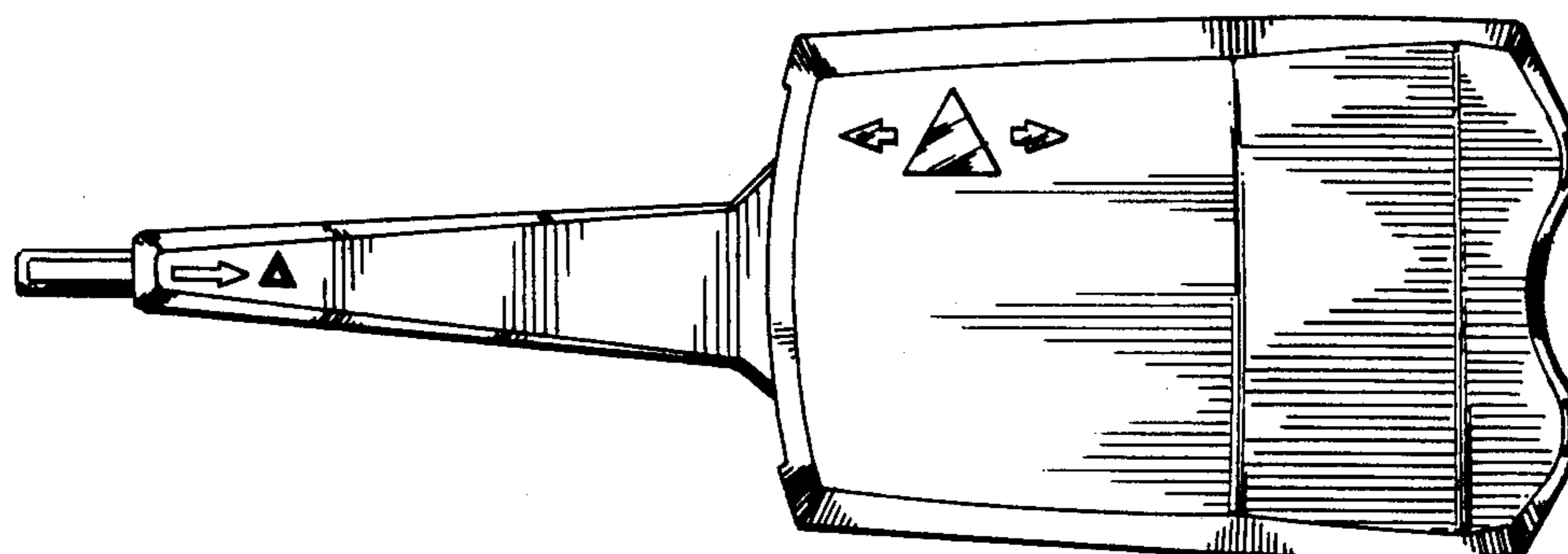

FIG. 2

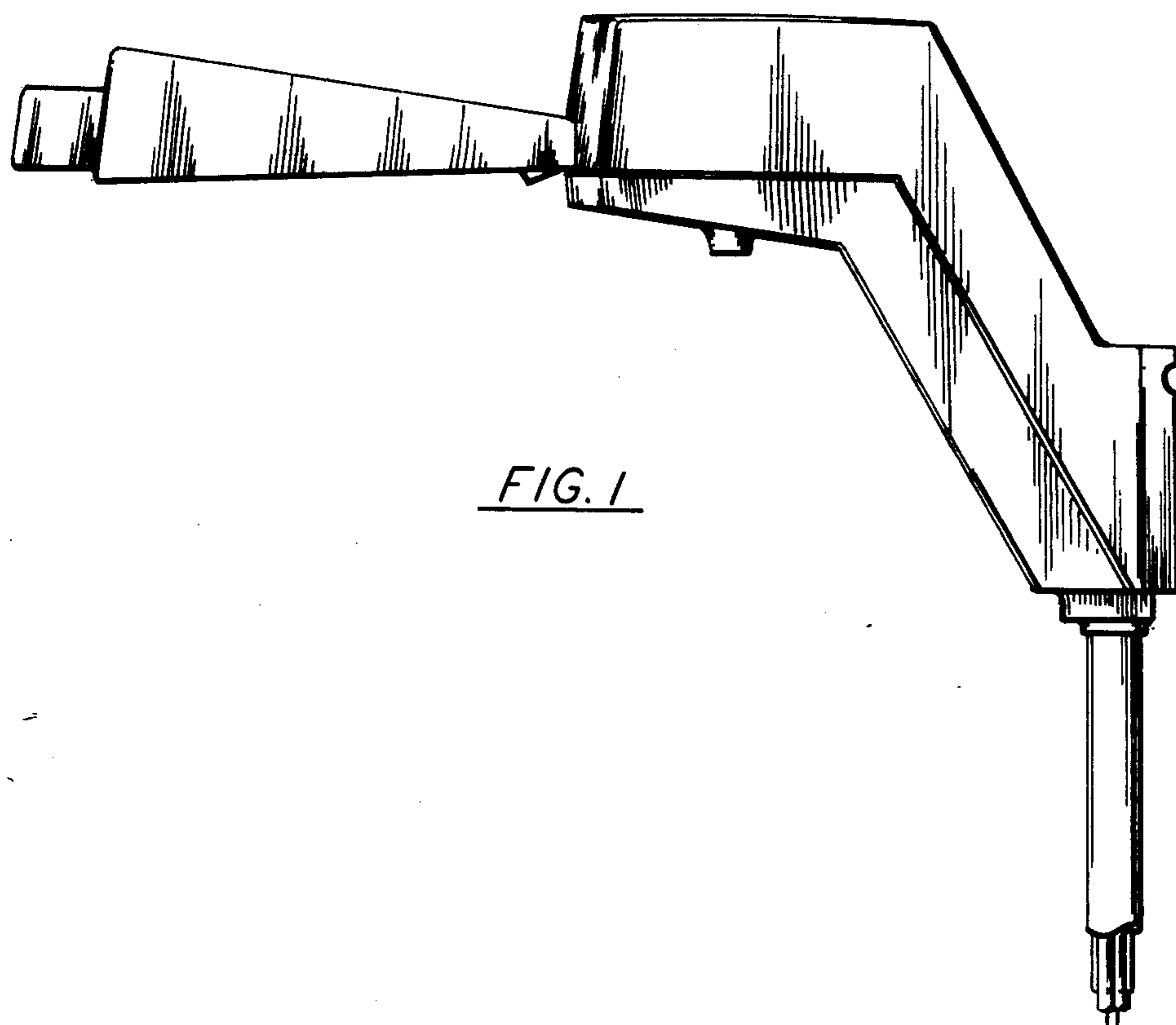

FIG. 1

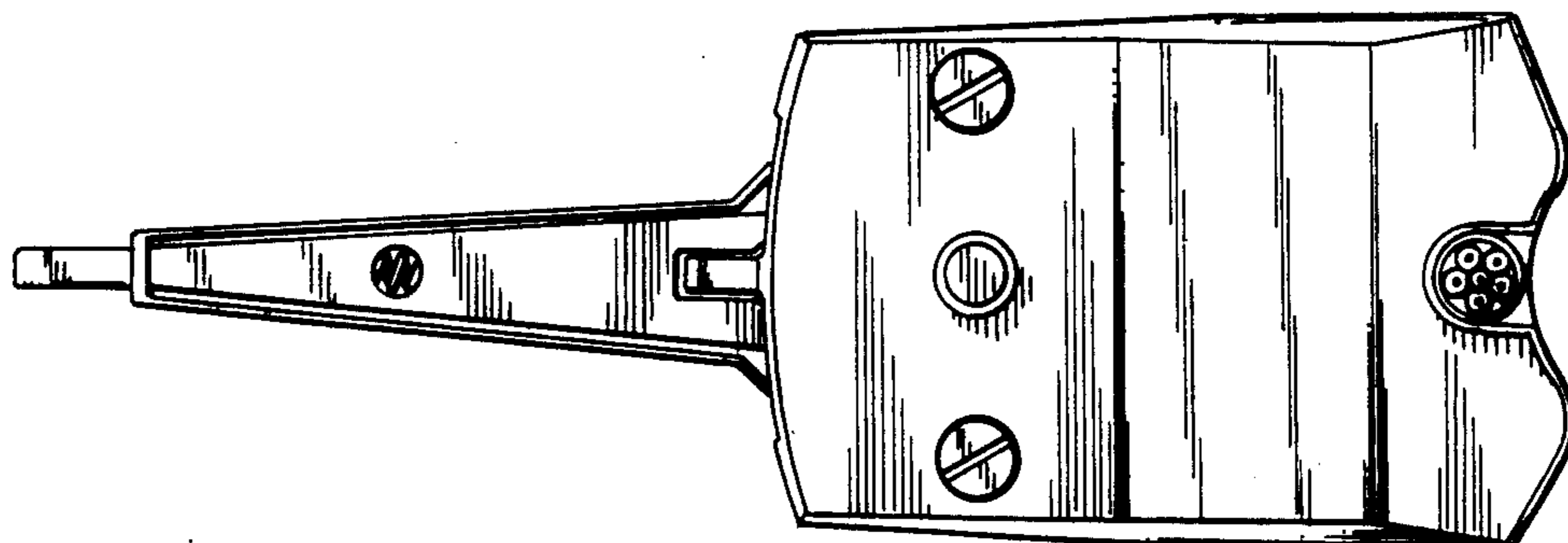

FIG. 3

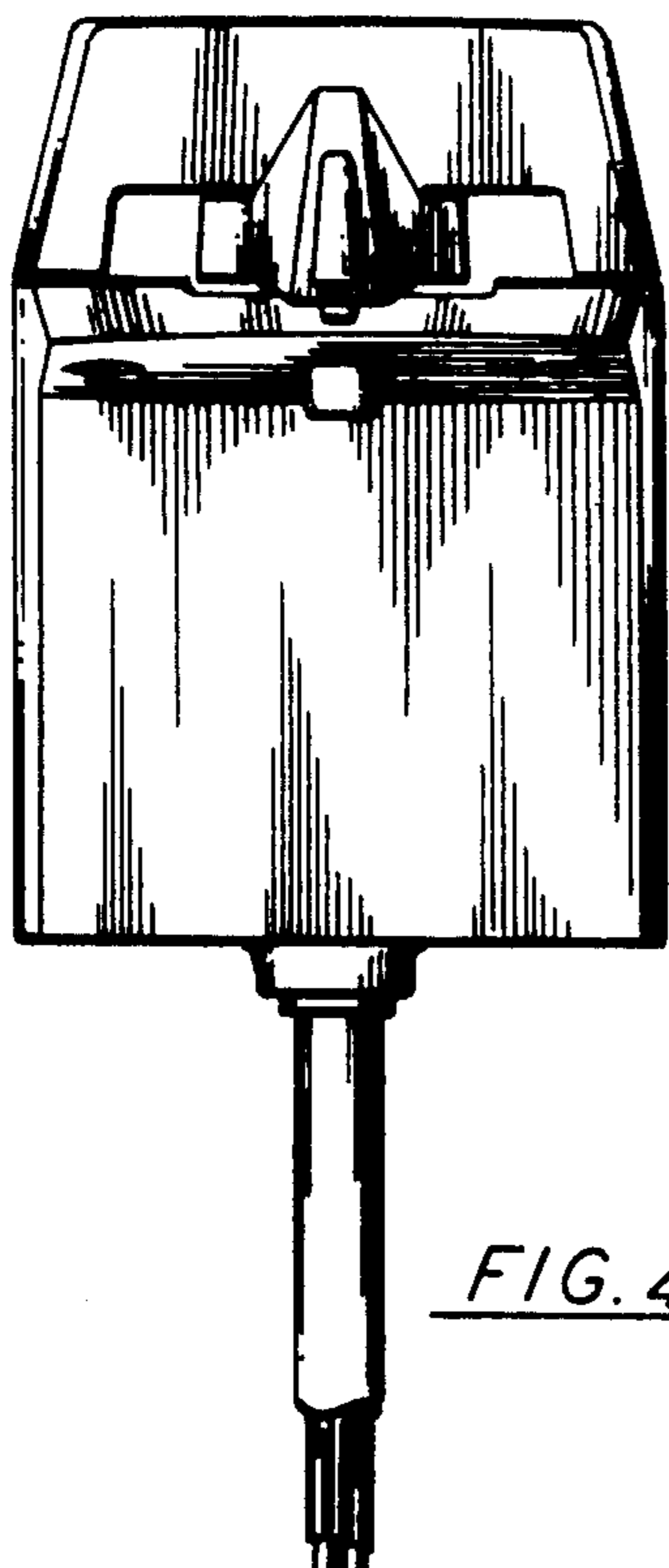

FIG. 4

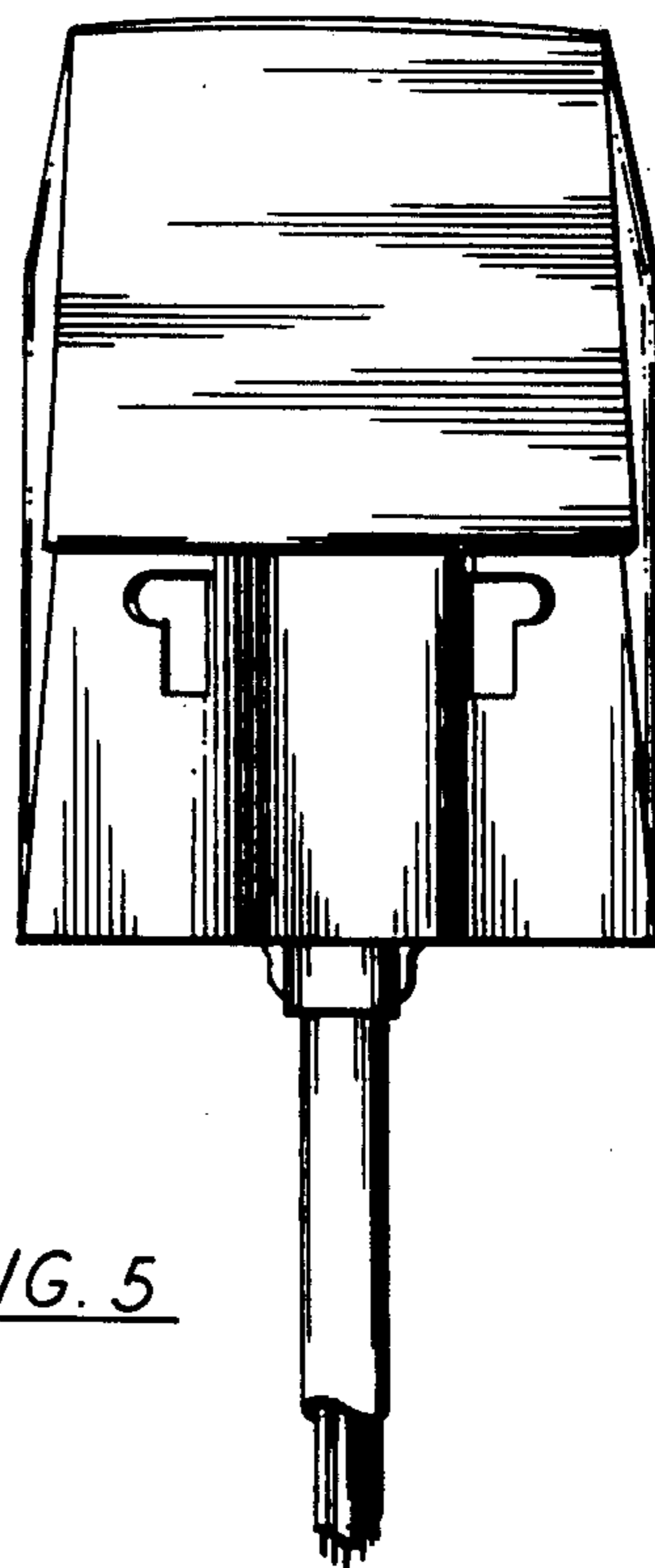

FIG. 5