

[54] MOUNTING BRACKET FOR A RAIL SYSTEM

[76] Inventor: Ernst F. Schindele, 505 W. Hill Rd., Stamford, Conn. 06905

[**] Term: 14 Years

[21] Appl. No.: 791,566

[22] Filed: Apr. 27, 1977

[51] Int. Cl. D8-08

[52] U.S. Cl. D8/363; D8/354; D25/38

[58] Field of Search 256/24, 59, 60, 61, 256/62, 63, 64, 65, 66, 67, 68; D25/38, 39, 42, 43, 44, 74, 75, 76, 73, 77, 78, 79; 248/223.4, 316, 309, 315, 224; D8/354, 361, 362, 363, 366, 373, 376, 380, 381

[56] References Cited

U.S. PATENT DOCUMENTS

3,540,687 11/1970 Cuva 248/223.4 X

OTHER PUBLICATIONS

Julius Blum & Co. Catalog 12, 1974, p. 144, joint cover, item 6805.

Primary Examiner—A. Hugo Word
Attorney, Agent, or Firm—Joseph Levinson

[57] CLAIM

The ornamental design for a mounting bracket for a rail system, as shown and described.

DESCRIPTION

FIG. 1 is a top view of the mounting bracket of my new design;

FIG. 2 is a left side elevational view.

FIG. 3 is a front elevation.

FIG. 4 is a right side elevation.

FIG. 5 is a bottom view of my mounting bracket.

FIG. 6 is a rear view.

FIG. 7 is an isometric view of the bracket from the rear.

FIG. 8 is a perspective view of the bracket.

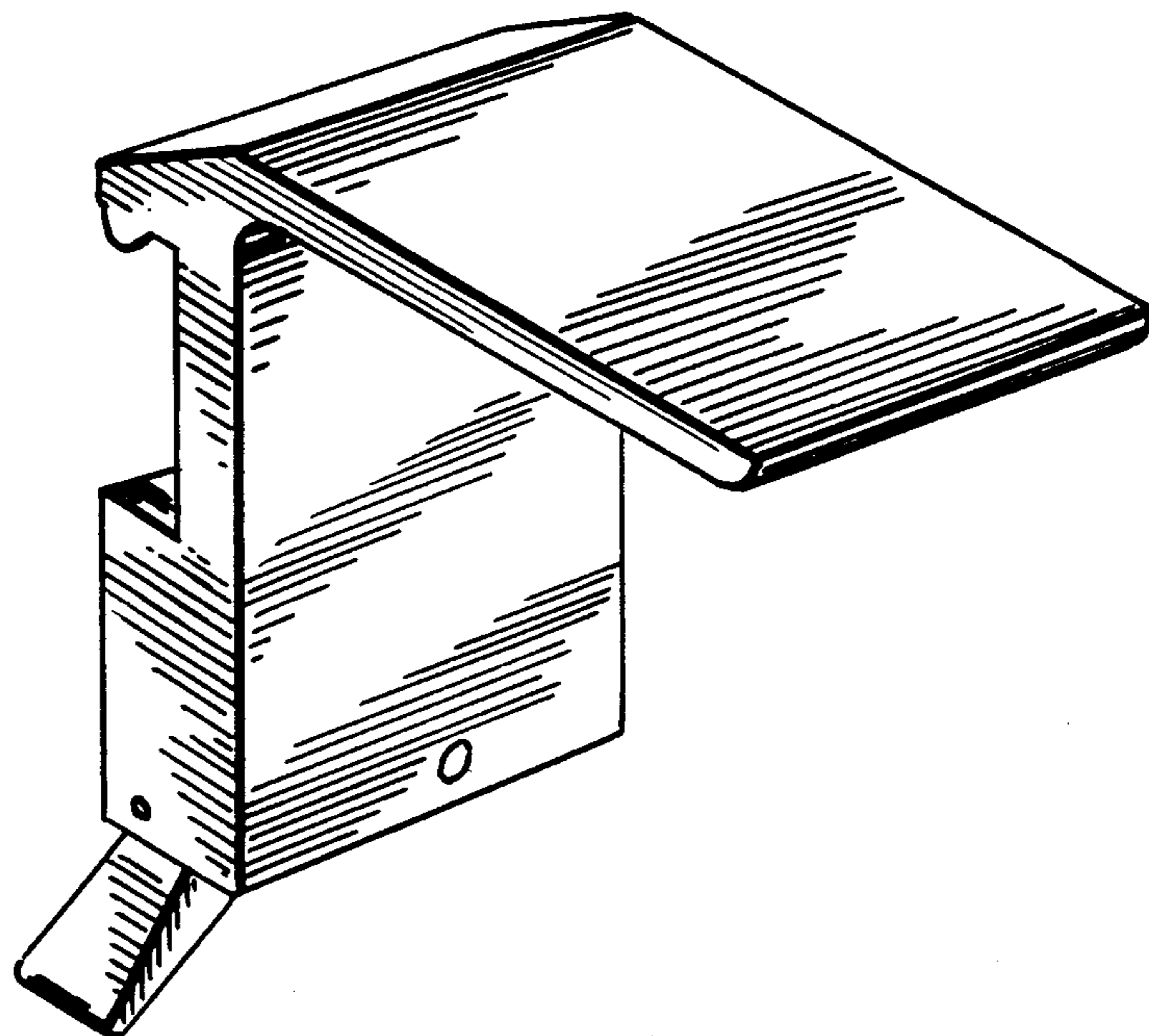

Fig. 1.

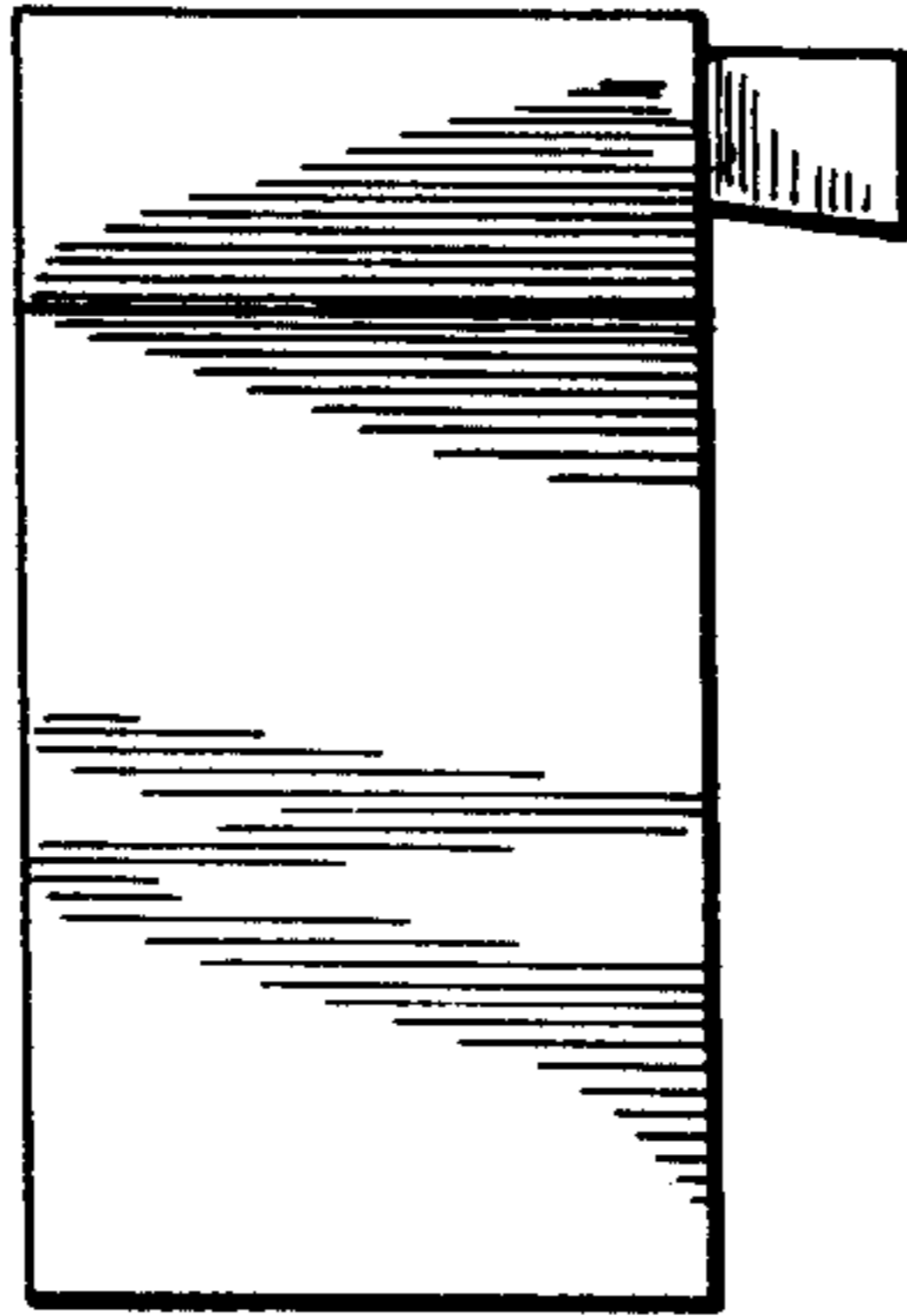

Fig. 2.

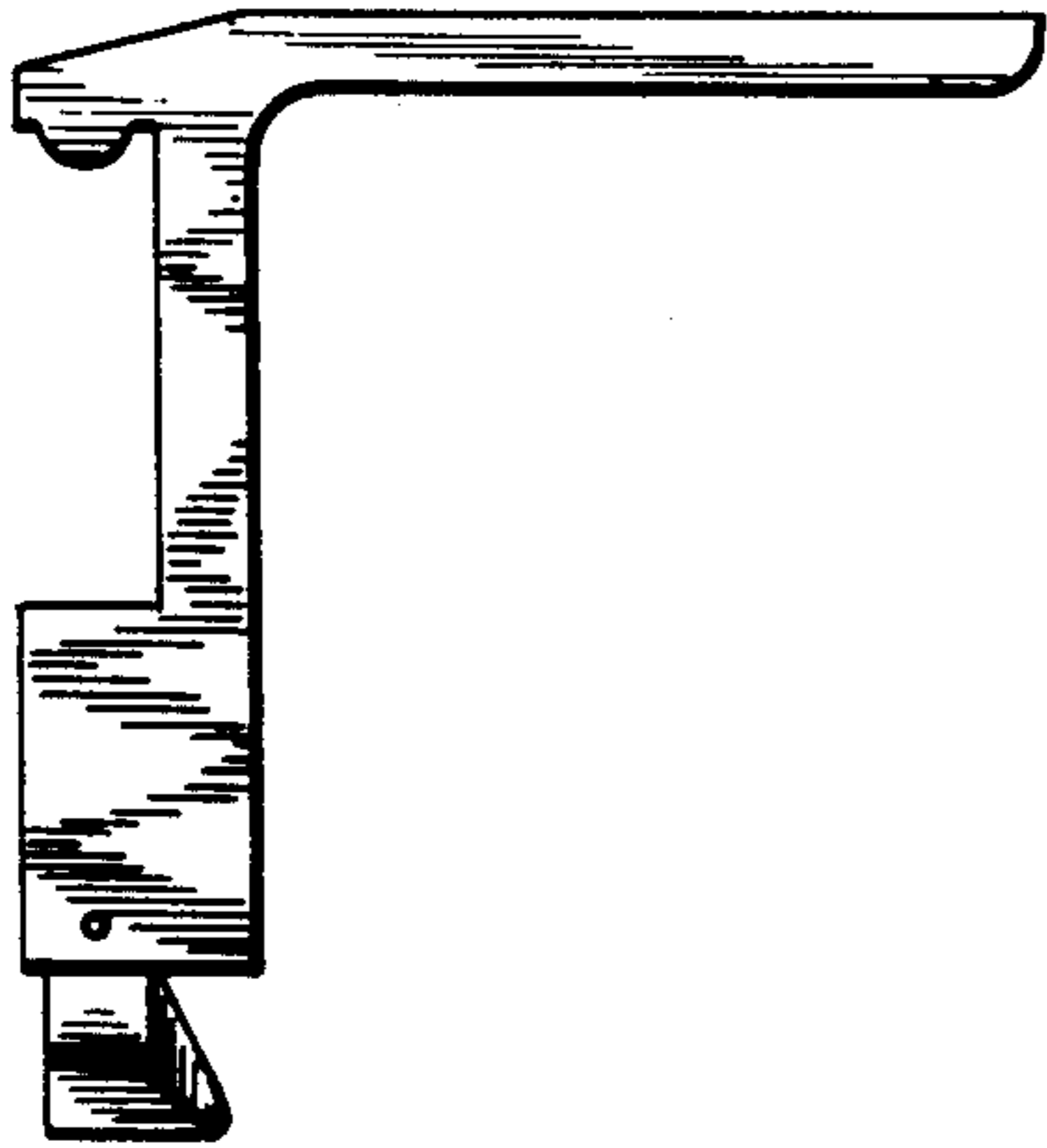

Fig. 4.

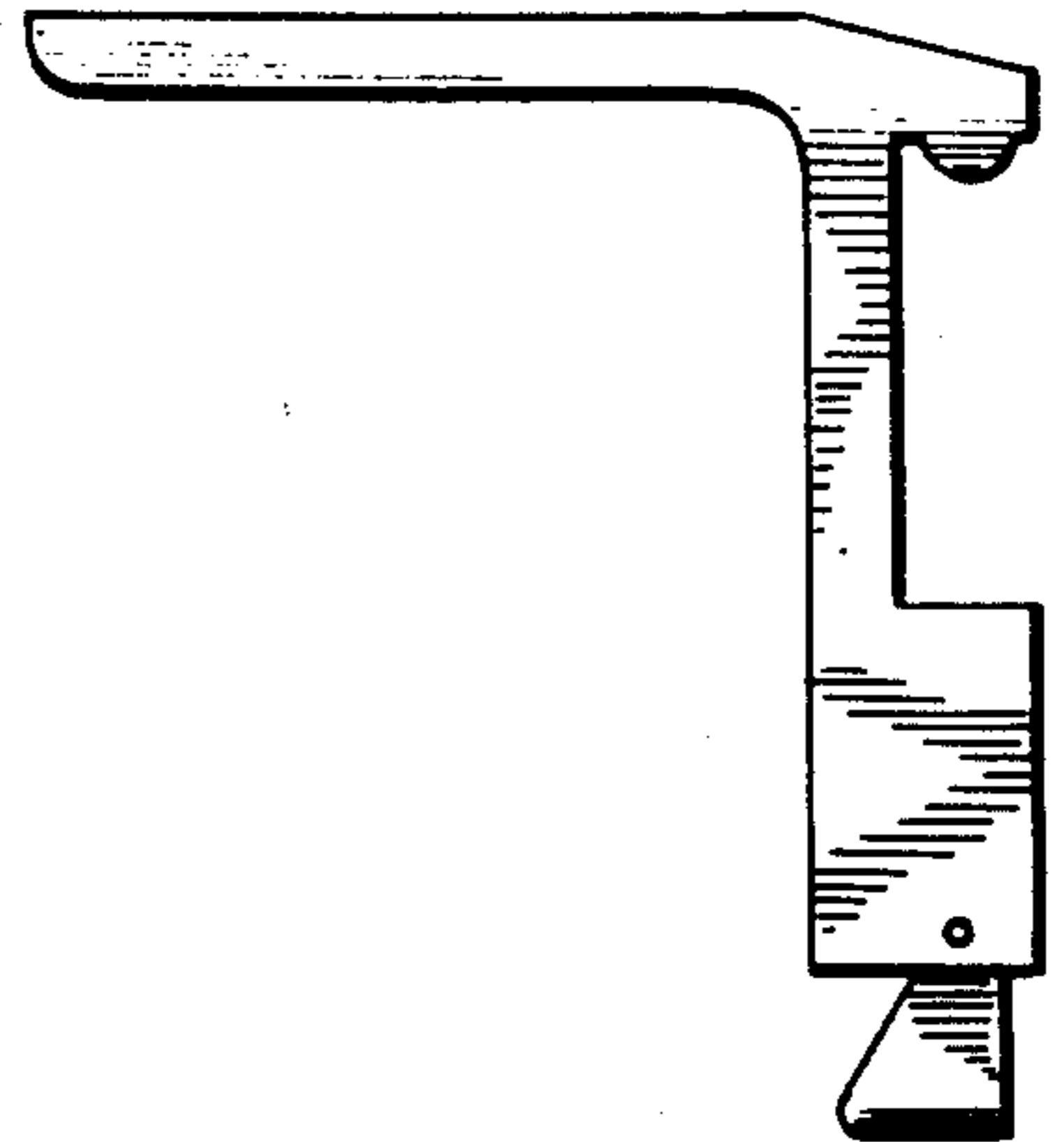

Fig. 3.

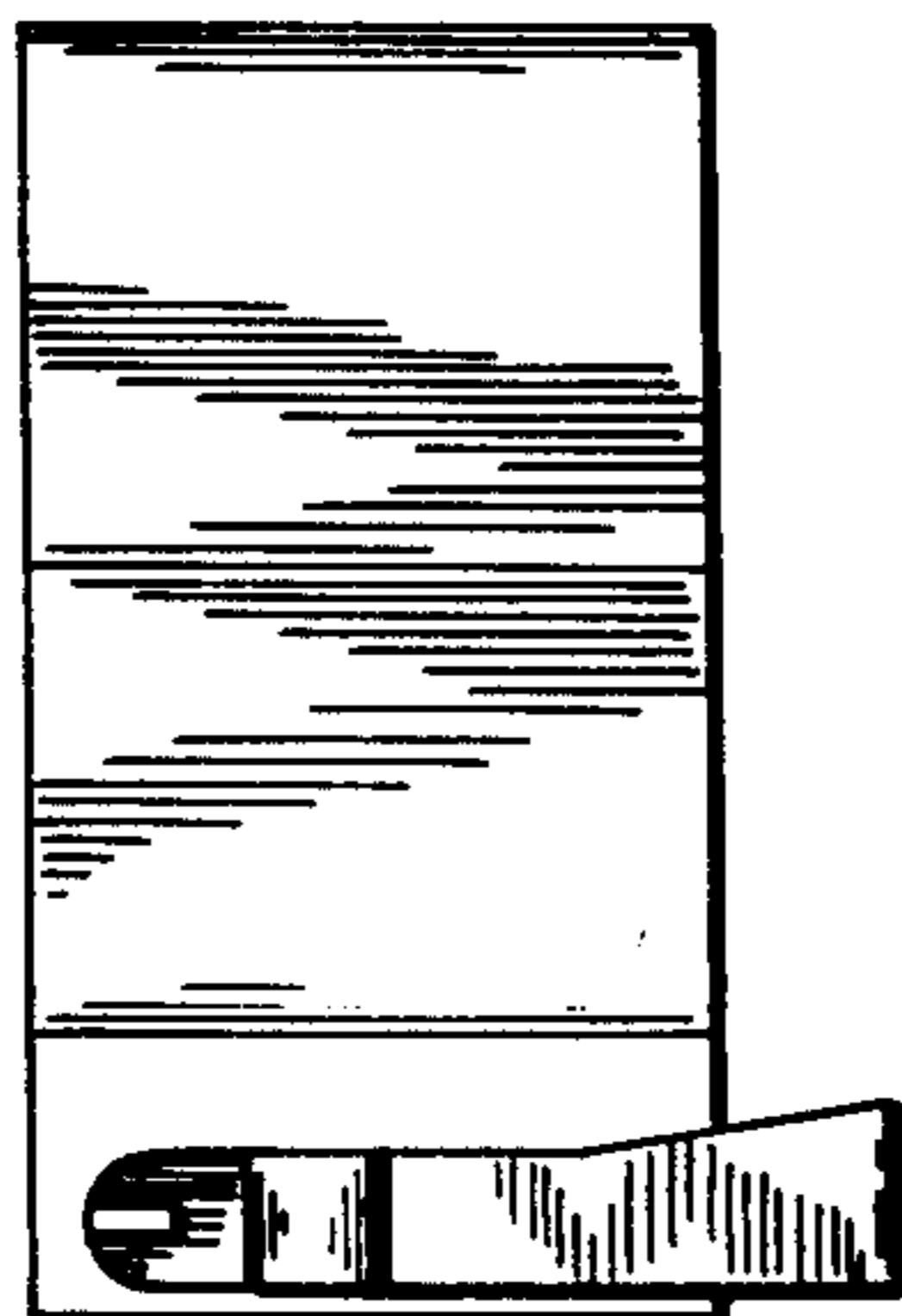

Fig. 5.

Fig. 6.

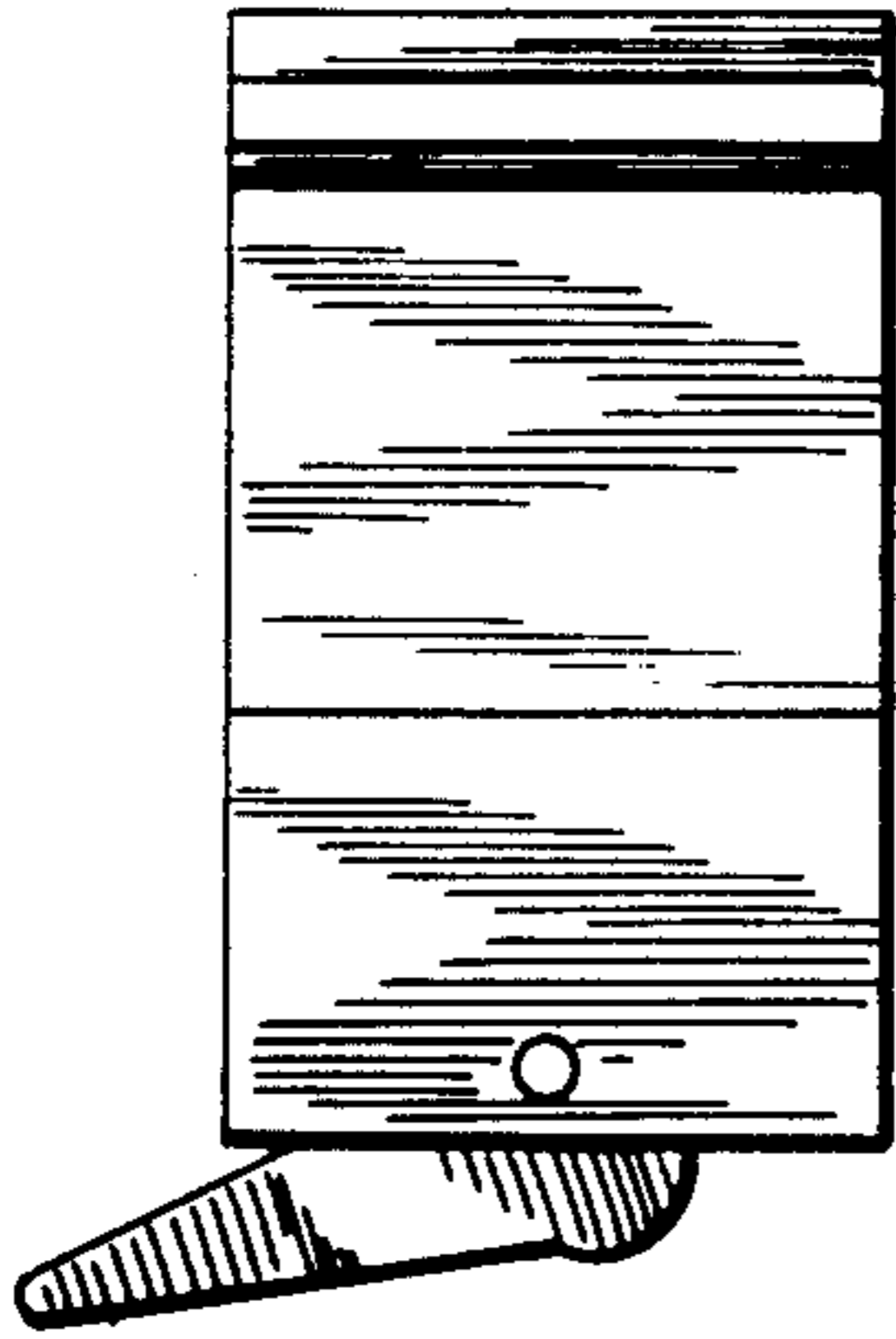

Fig. 7.

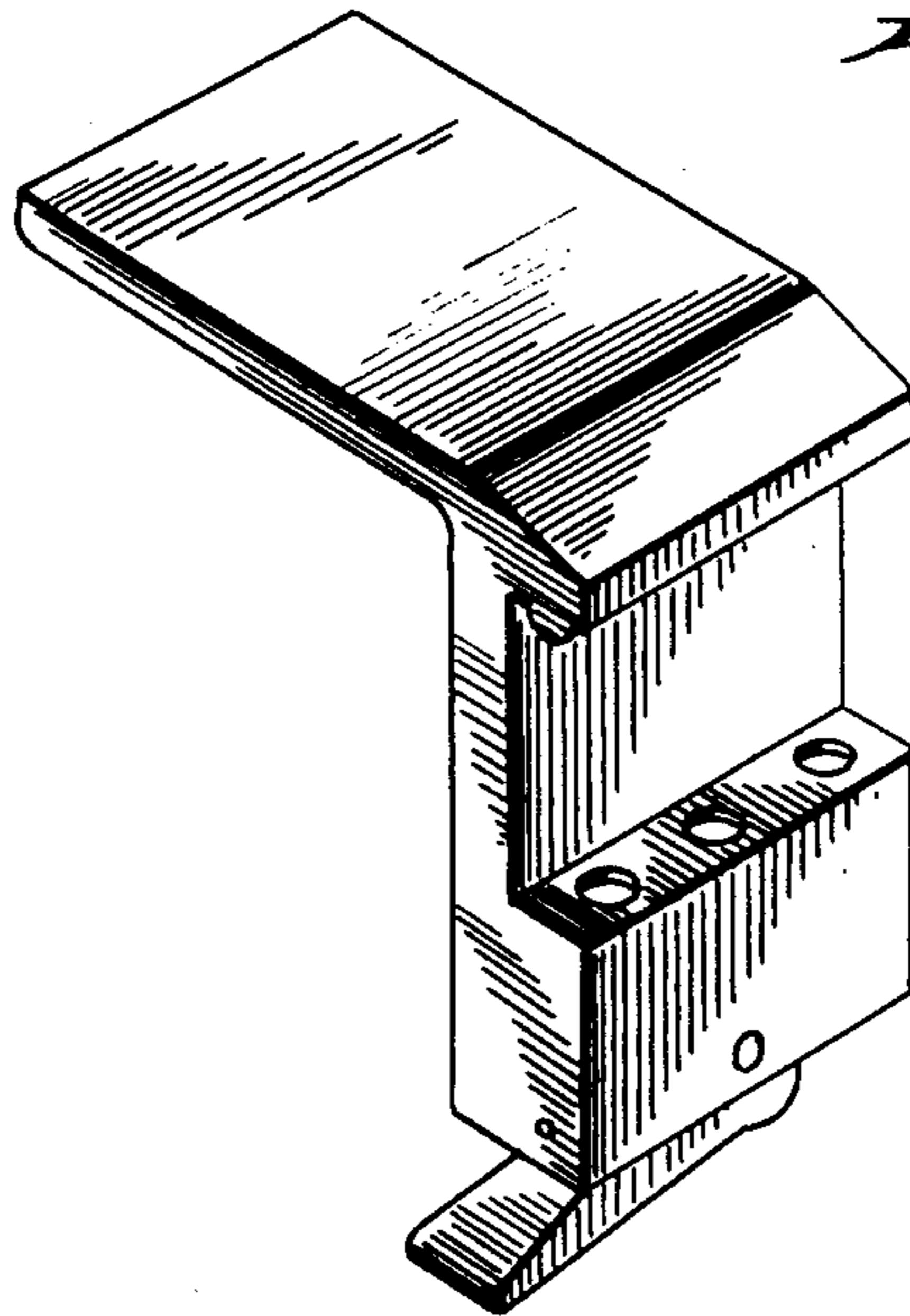

Fig. 8.

