

[54] **STARTING FLUID VALVE ASSEMBLY FOR DIESEL STARTING SYSTEMS**

[75] **Inventors:** John W. Krueger; John D. Krueger, both of Glenview, Ill.

[73] **Assignee:** Phillips, Division of James B. Carter, Inc., Minneapolis, Minn.

[**] **Term:** 14 Years

[21] **Appl. No.:** 880,218

[22] **Filed:** Feb. 22, 1978

[51] **Int. Cl.** D15-01

[52] **U.S. Cl.** D12/5; D23/19; D24/99

[58] **Field of Search** D24/8; D23/19, 20, 21; 128/214 E, 214 F, DIG. 12, DIG. 13; 137/197, 377; D15/5; 251/294, 129

[56] **References Cited**

U.S. PATENT DOCUMENTS

D. 228,814	10/1973	Peraire	D15/5
D. 246,908	1/1978	Fetty	D23/19
3,954,250	5/1976	Grace	251/294
4,091,348	5/1978	Kawamoto et al.	251/129

Primary Examiner—Bernard Ansher
Attorney, Agent, or Firm—Everett J. Schroeder

[57] **CLAIM**

The ornamental design for a starting fluid valve assembly for diesel starting systems, as shown and described.

DESCRIPTION

FIG. 1 is a top plan view of our new starting fluid valve assembly for diesel starting systems; FIG. 2 is a front elevational view thereof; FIG. 3 is a side elevational view thereof; FIG. 4 is a rear elevational view thereof; and FIG. 5 is a bottom plan view thereof. A side elevational view taken from the side opposite that shown in FIG. 3 is essentially a mirror image thereof.

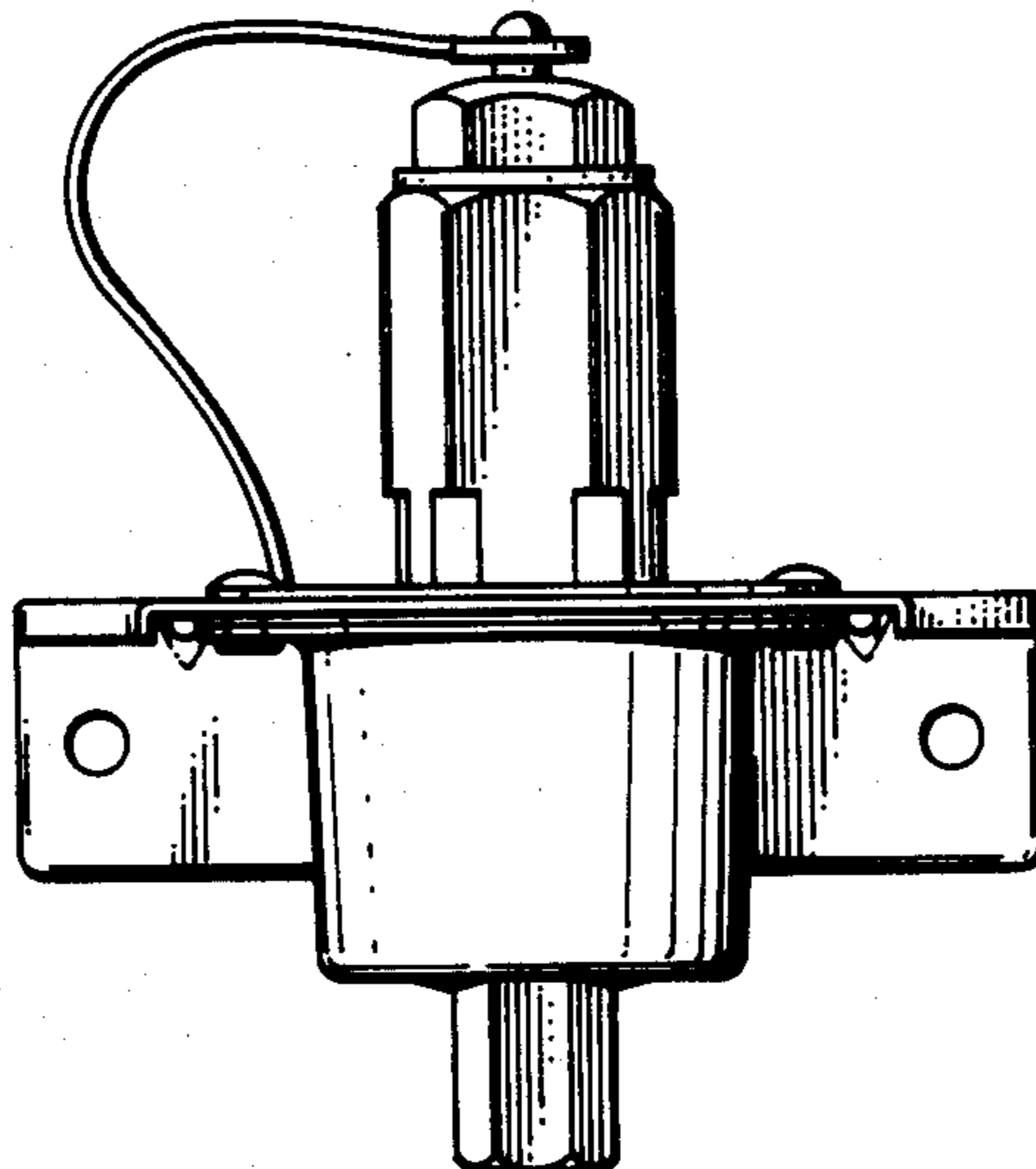
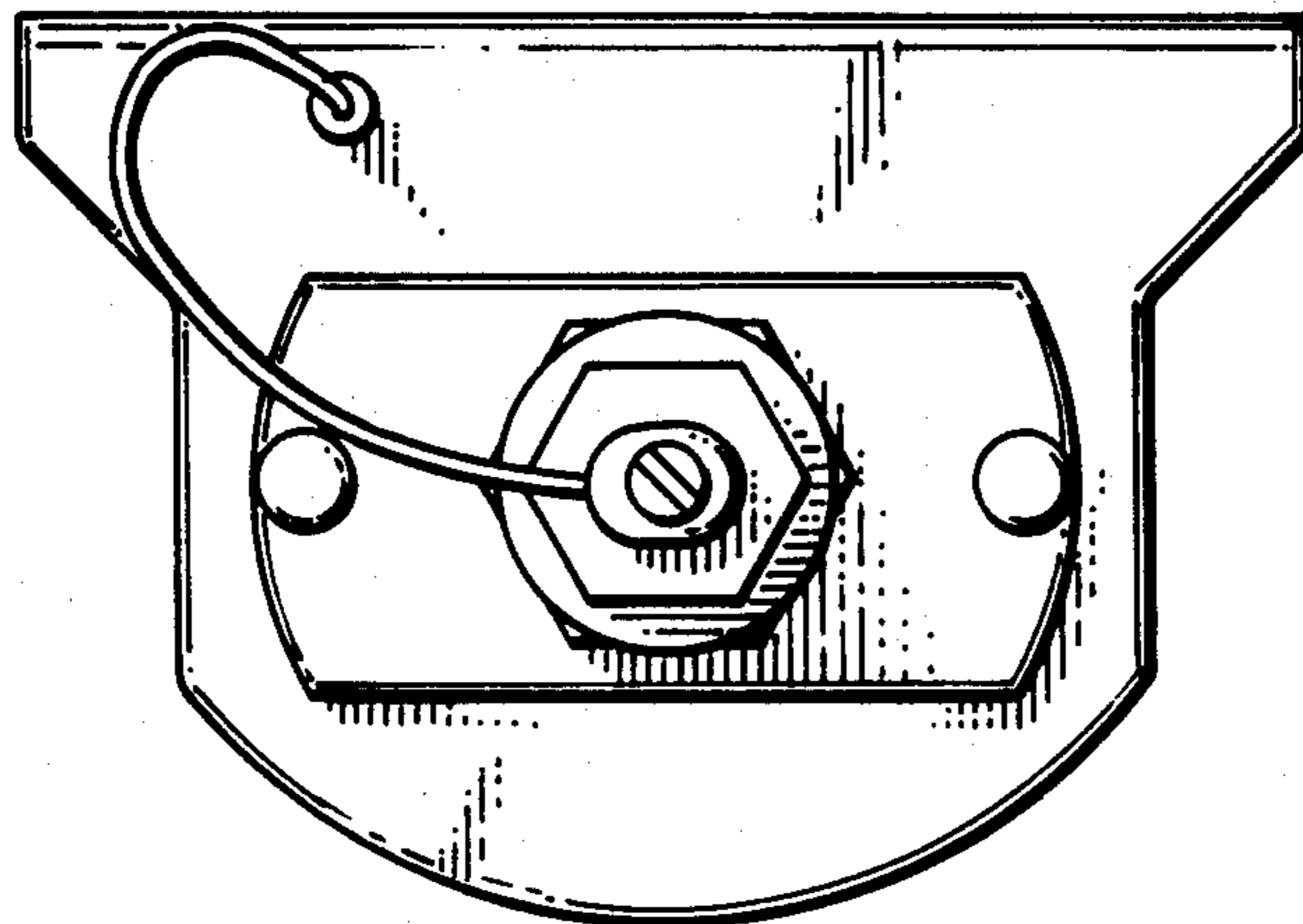

Fig. 1

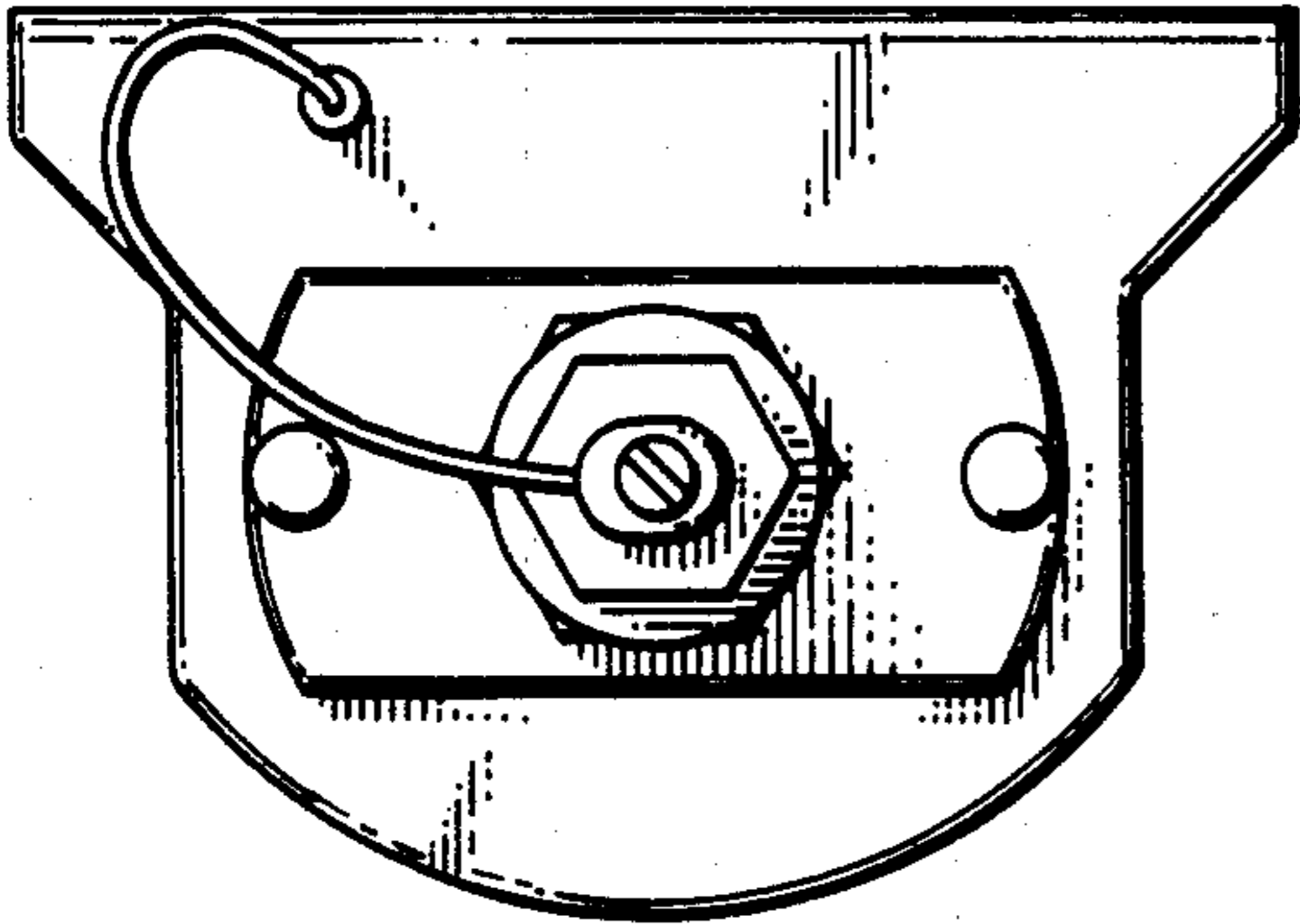

Fig. 2

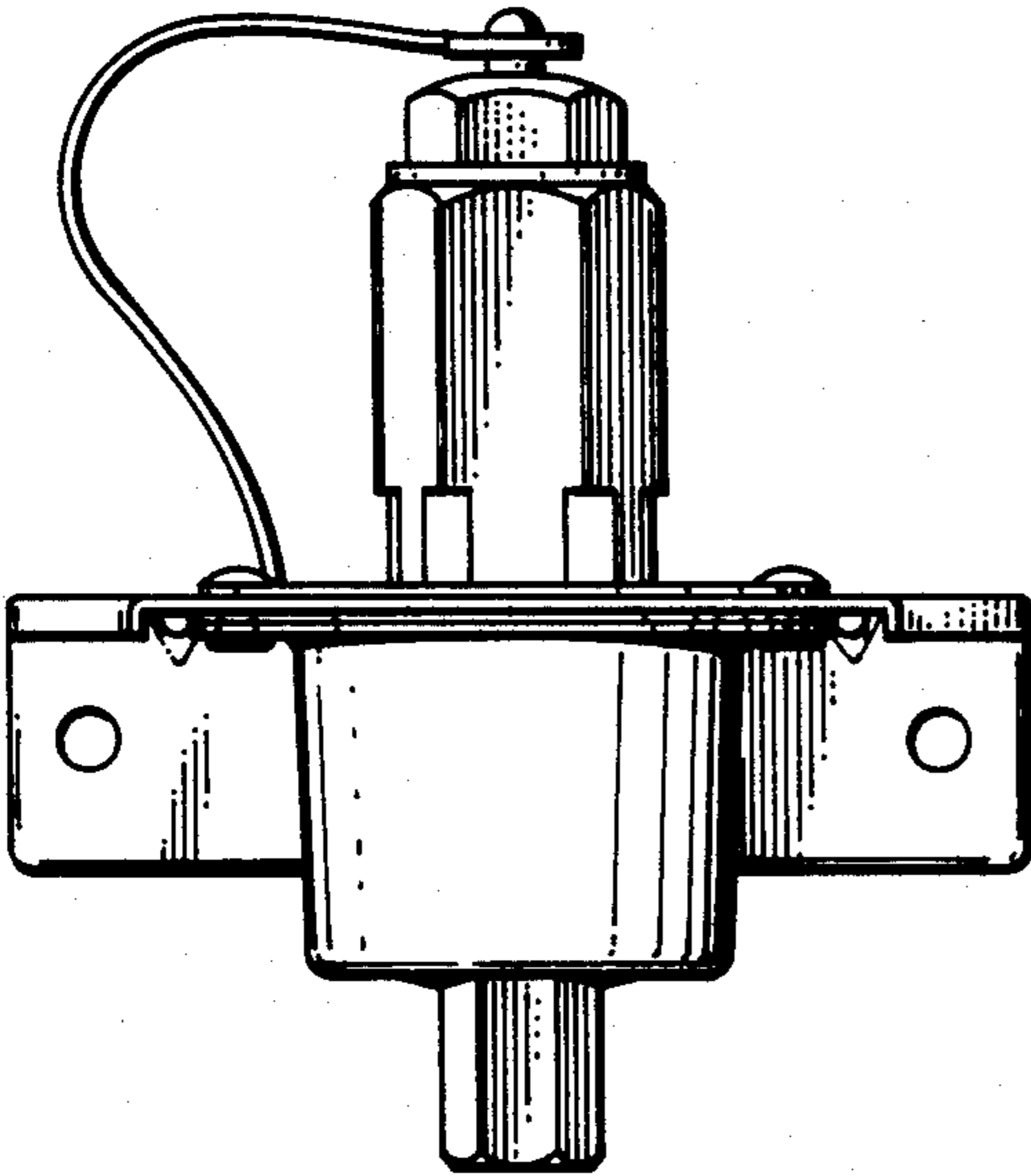

Fig. 3

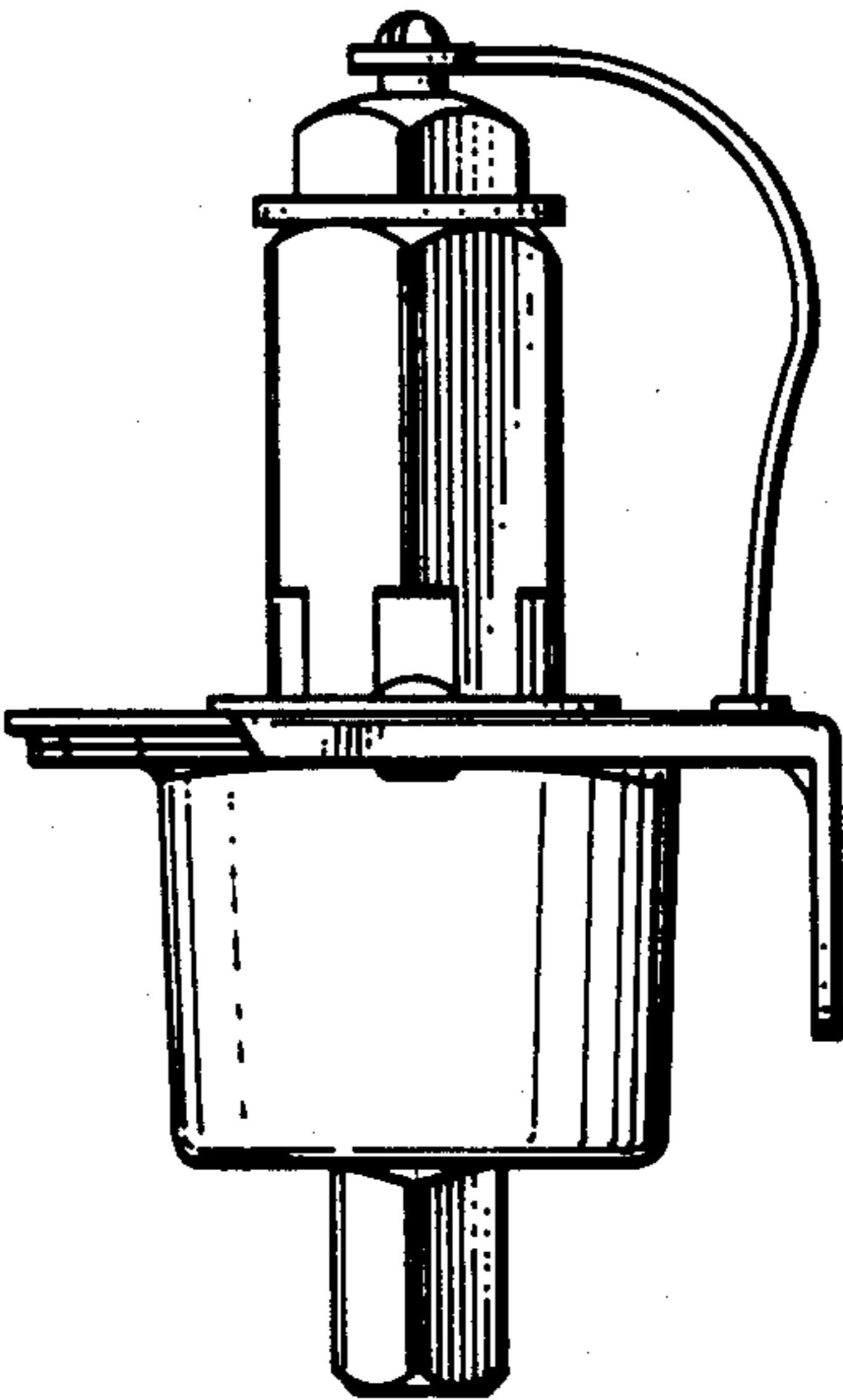

Fig. 5

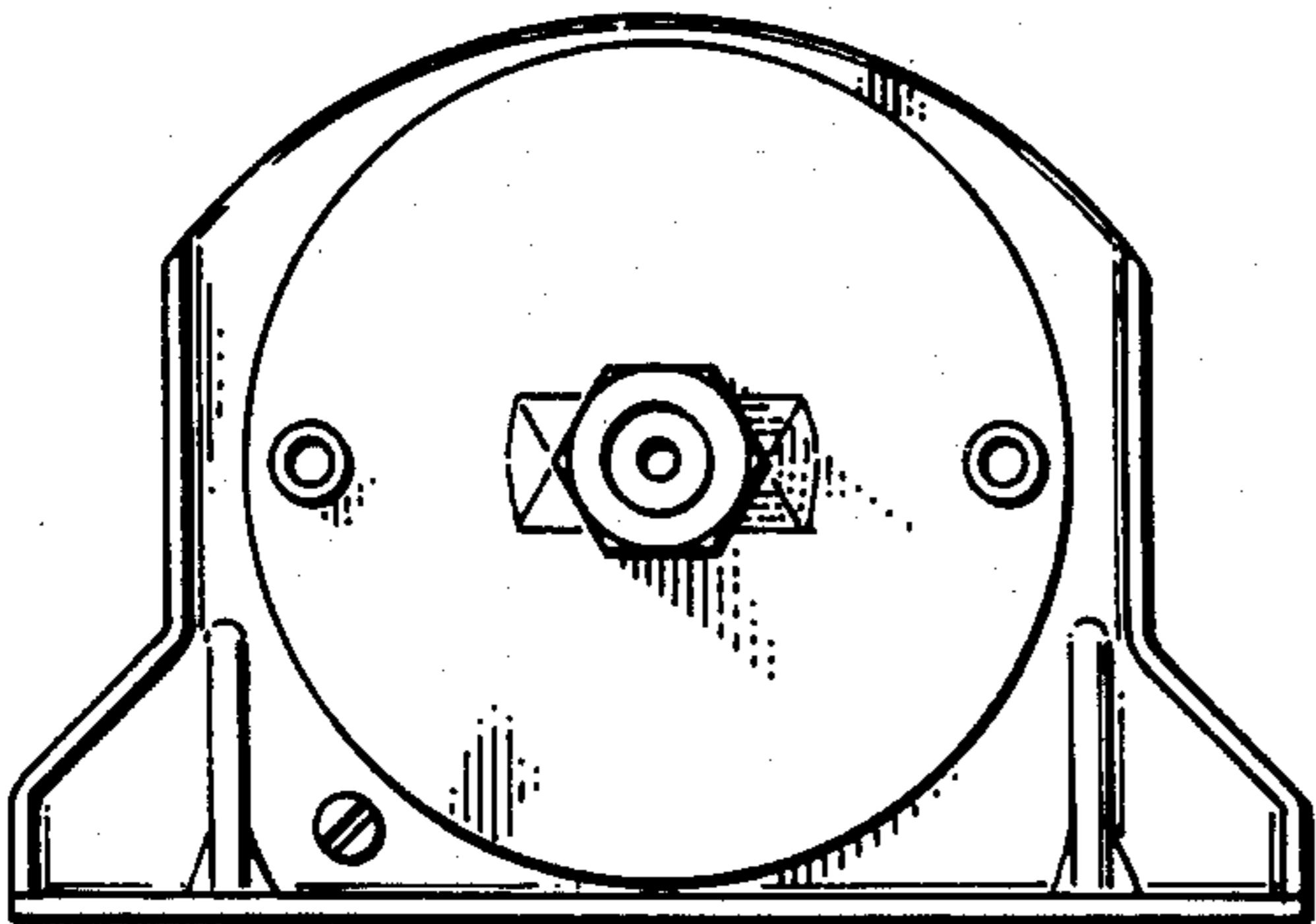

Fig. 4

