

[54] JEWELER'S METAL MOLD ASSEMBLY

[76] Inventor: Andrew S. Waters, 6219 Del Norte, Dallas, Tex. 75225

[**] Term: 14 Years

[21] Appl. No.: 728,983

[22] Filed: Oct. 4, 1976

[51] Int. Cl.² D15-09

[52] U.S. Cl. D15/136

[58] Field of Search D15/136; 249/174

[56] References Cited

U.S. PATENT DOCUMENTS

D. 233,254 10/1974 Abuza et al. D15/136

Primary Examiner—Alan P. Douglas

Attorney, Agent, or Firm—E. Mickey Hubbard

[57] CLAIM

The ornamental design for a jeweler's metal mold assembly, as shown and described.

DESCRIPTION

FIG. 1 is a perspective view from the front of the jeweler's metal mold assembly of this invention with the mold sections open for completeness of disclosure; FIG. 2 is a perspective view from the back of the jeweler's metal mold assembly of FIG. 1 with the mold sections open for completeness of disclosure; FIG. 3 is a back elevational view of the jeweler's metal mold assembly of FIG. 1; FIG. 4 is a side elevational view of the left side of the jeweler's metal mold assembly of FIG. 1 with the mold sections closed; FIG. 5 is a top view of the jeweler's metal mold assembly of FIG. 1 with the mold sections closed; FIG. 6 is a bottom view of the jeweler's metal mold assembly of FIG. 1; FIG. 7 is a front elevational view of the jeweler's metal mold assembly of FIG. 1; and FIG. 8 is a side elevational view of the right side of the jeweler's metal mold assembly of FIG. 1 with the mold sections closed.

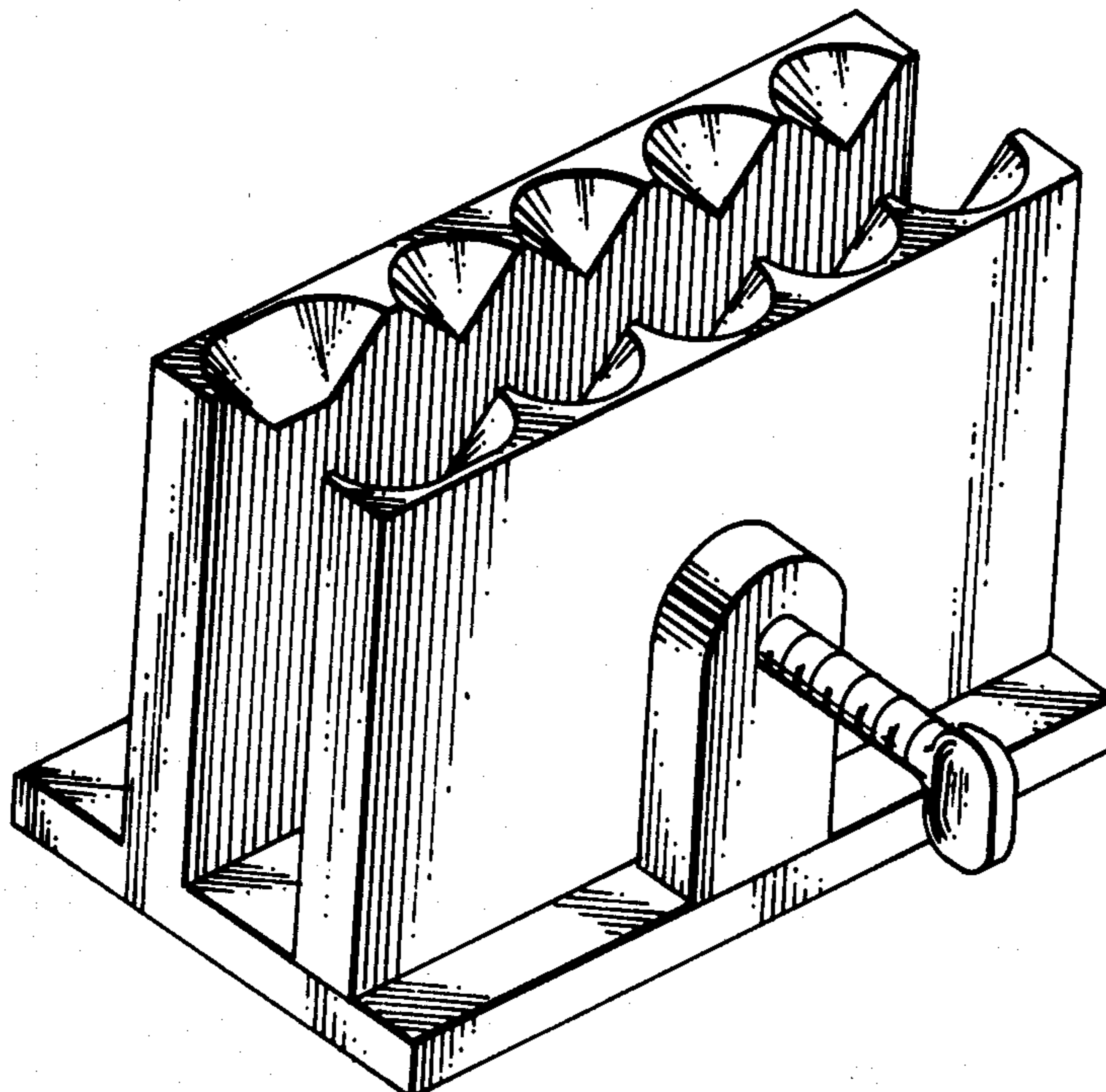

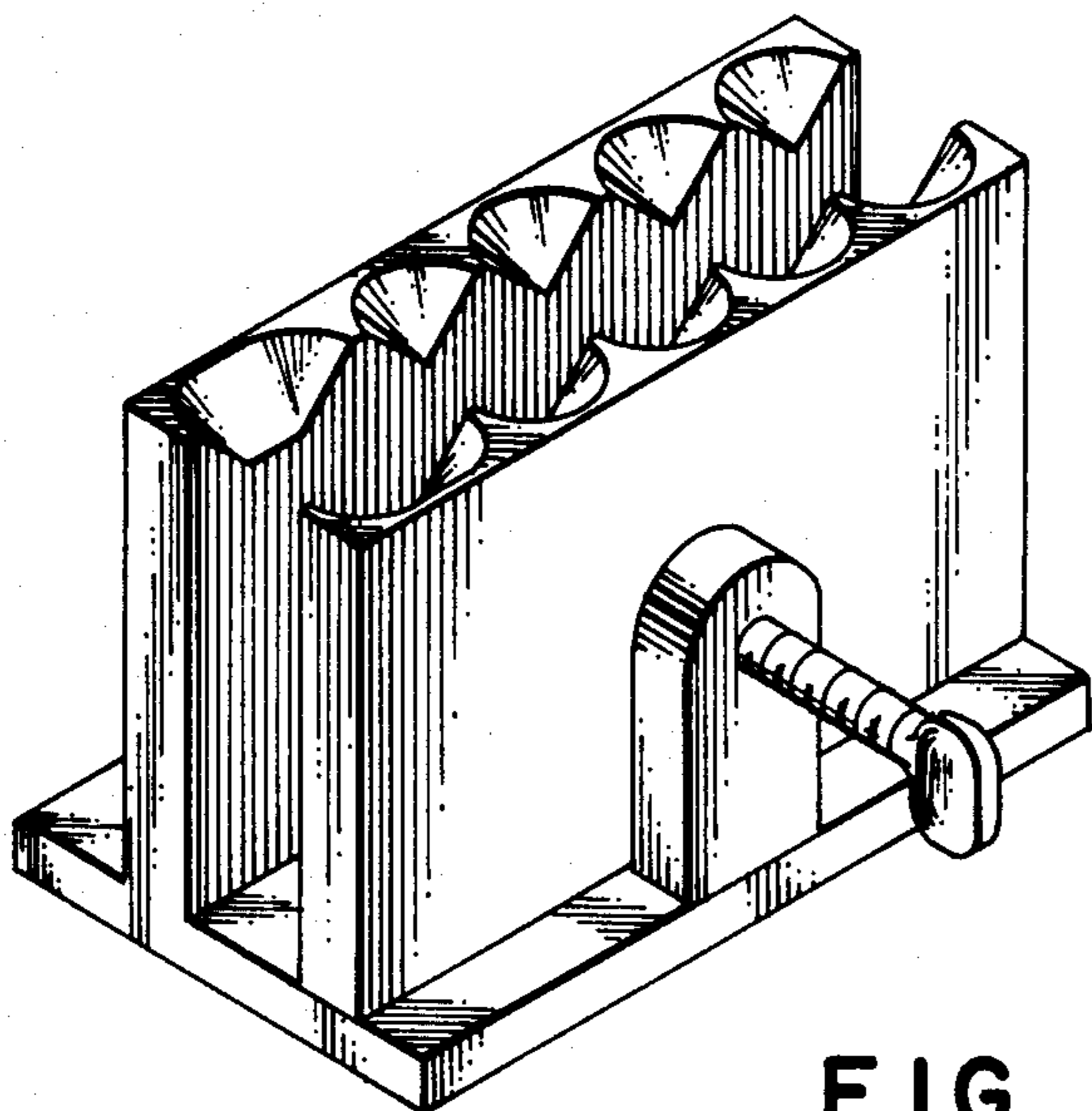

FIG. 1

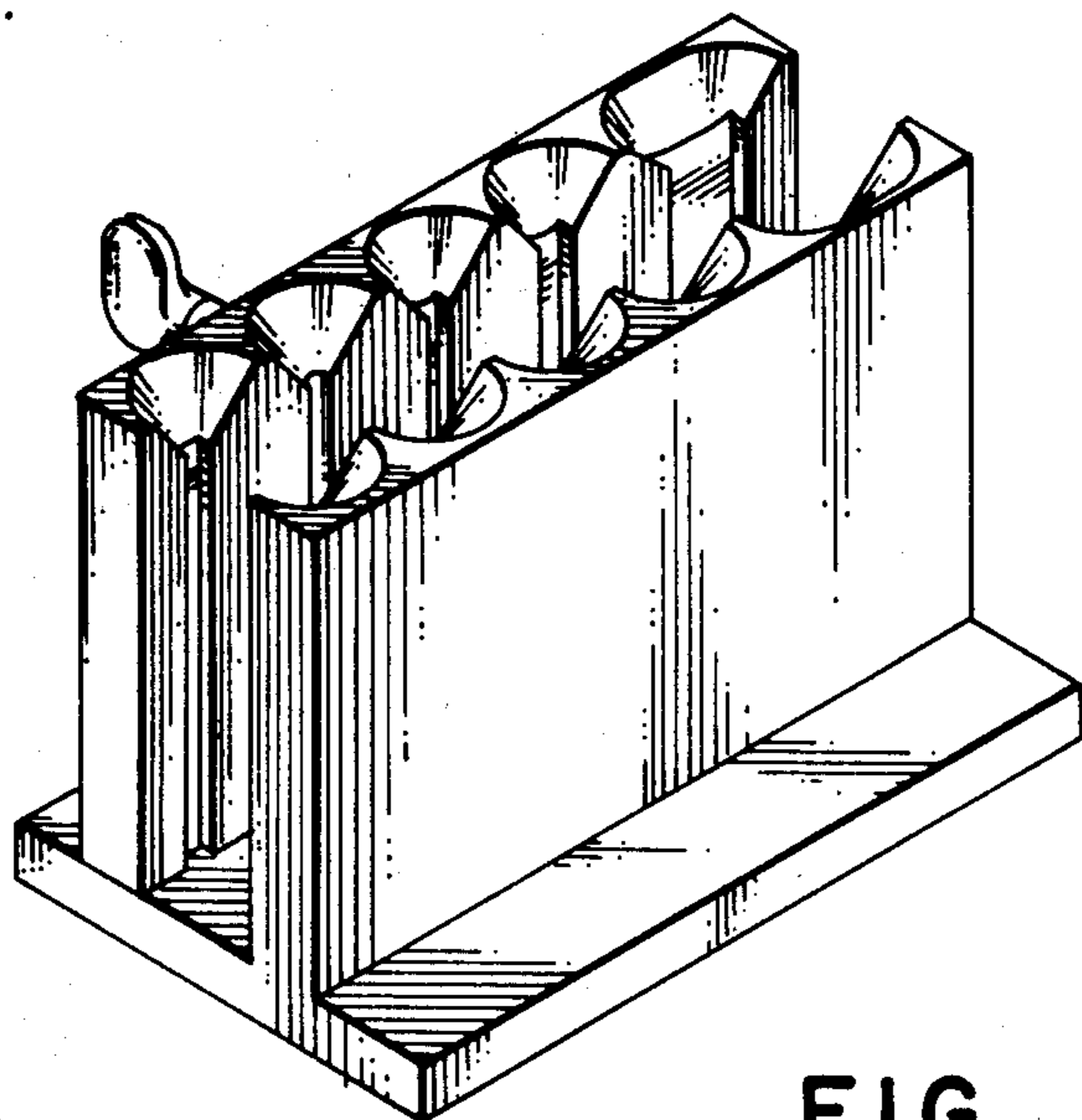

FIG. 2

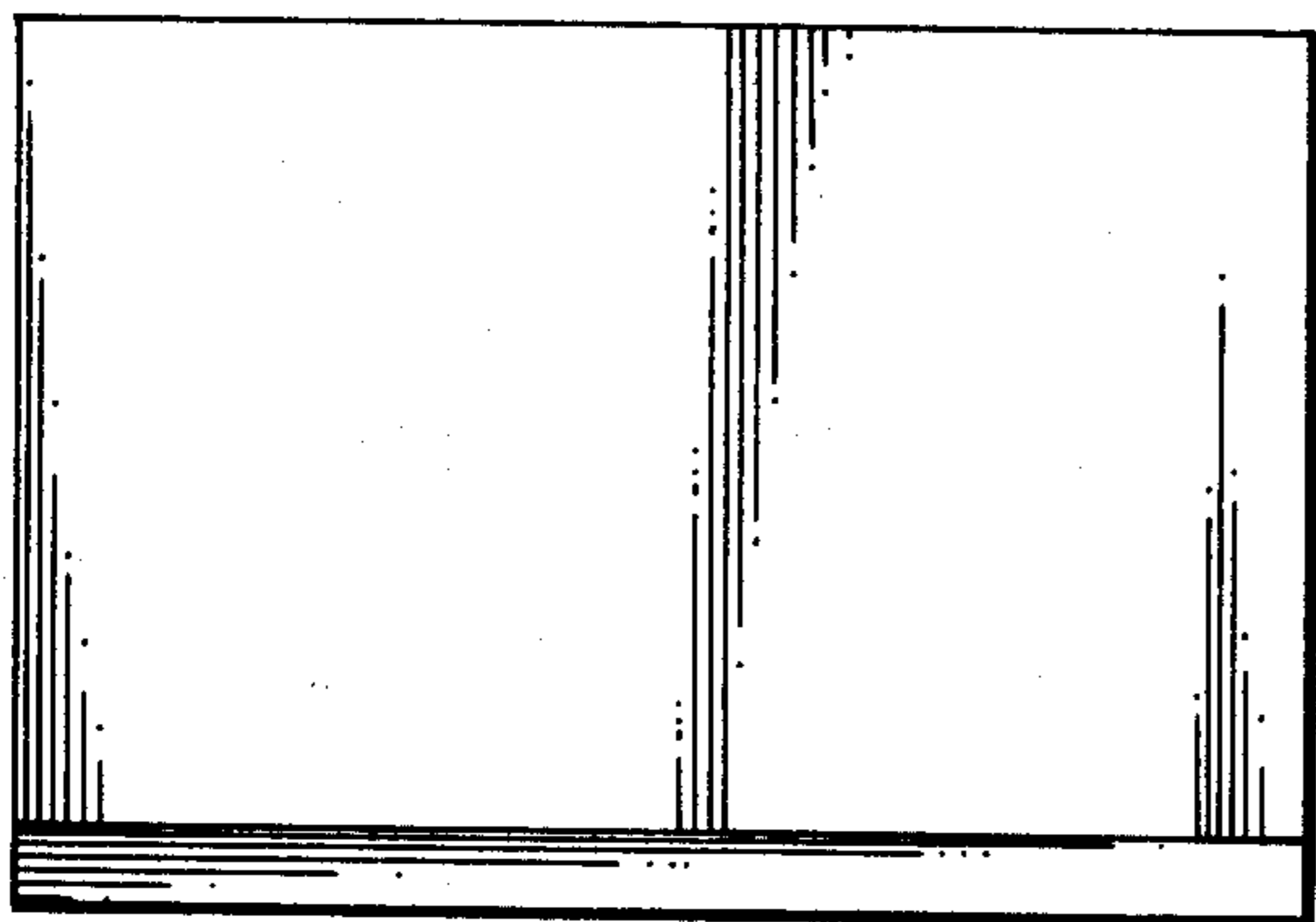

FIG. 3

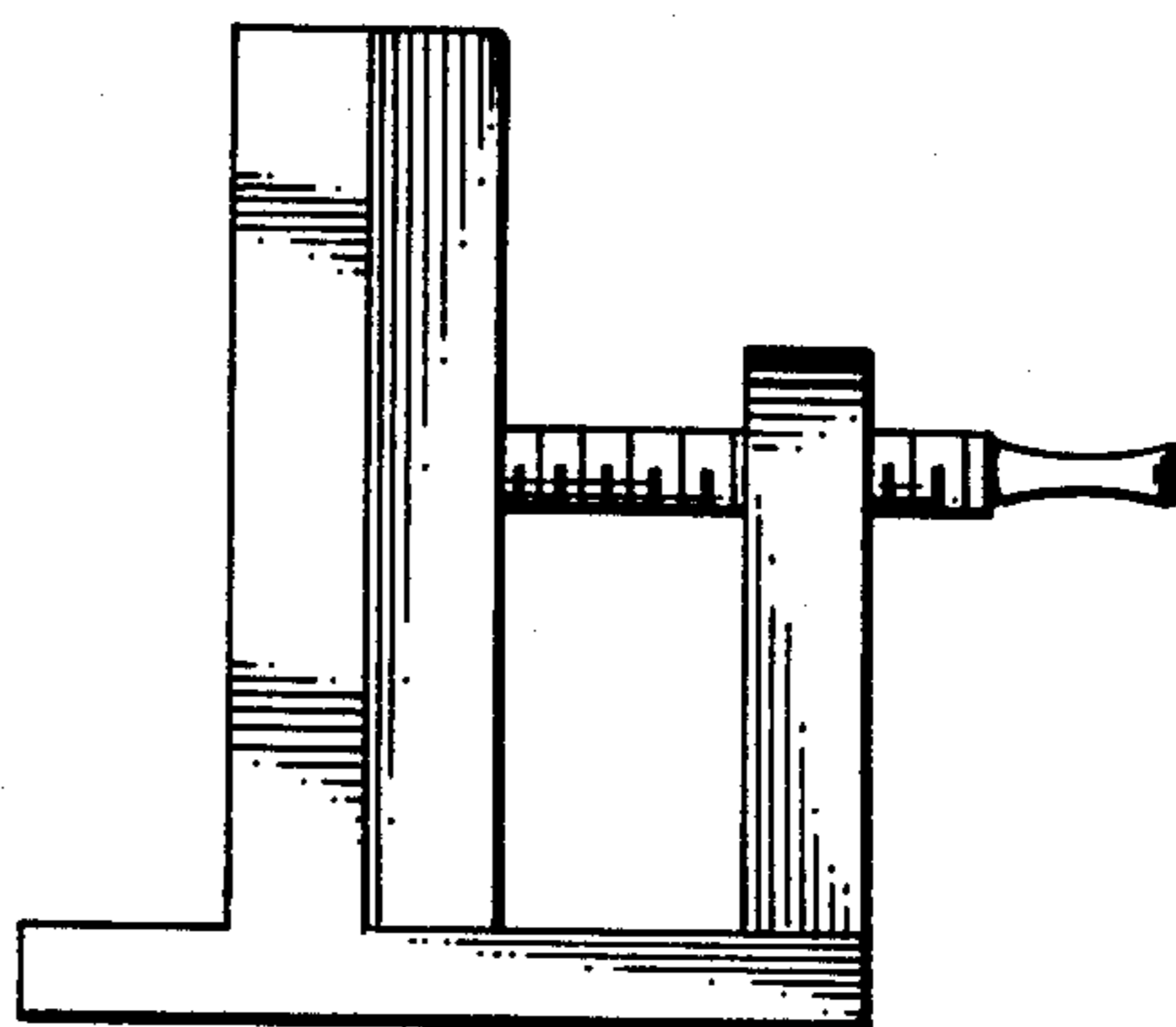

FIG. 4

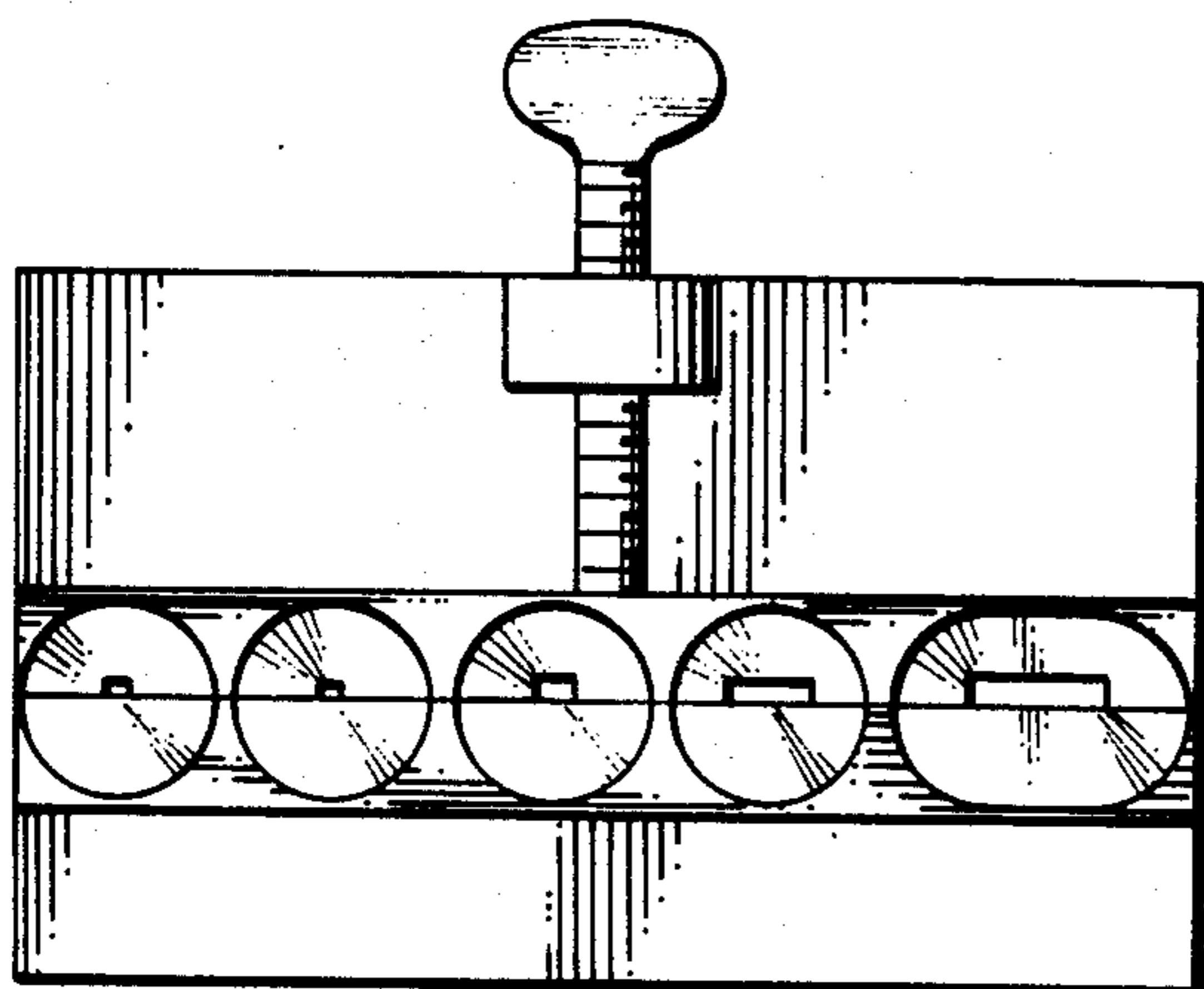

FIG. 5

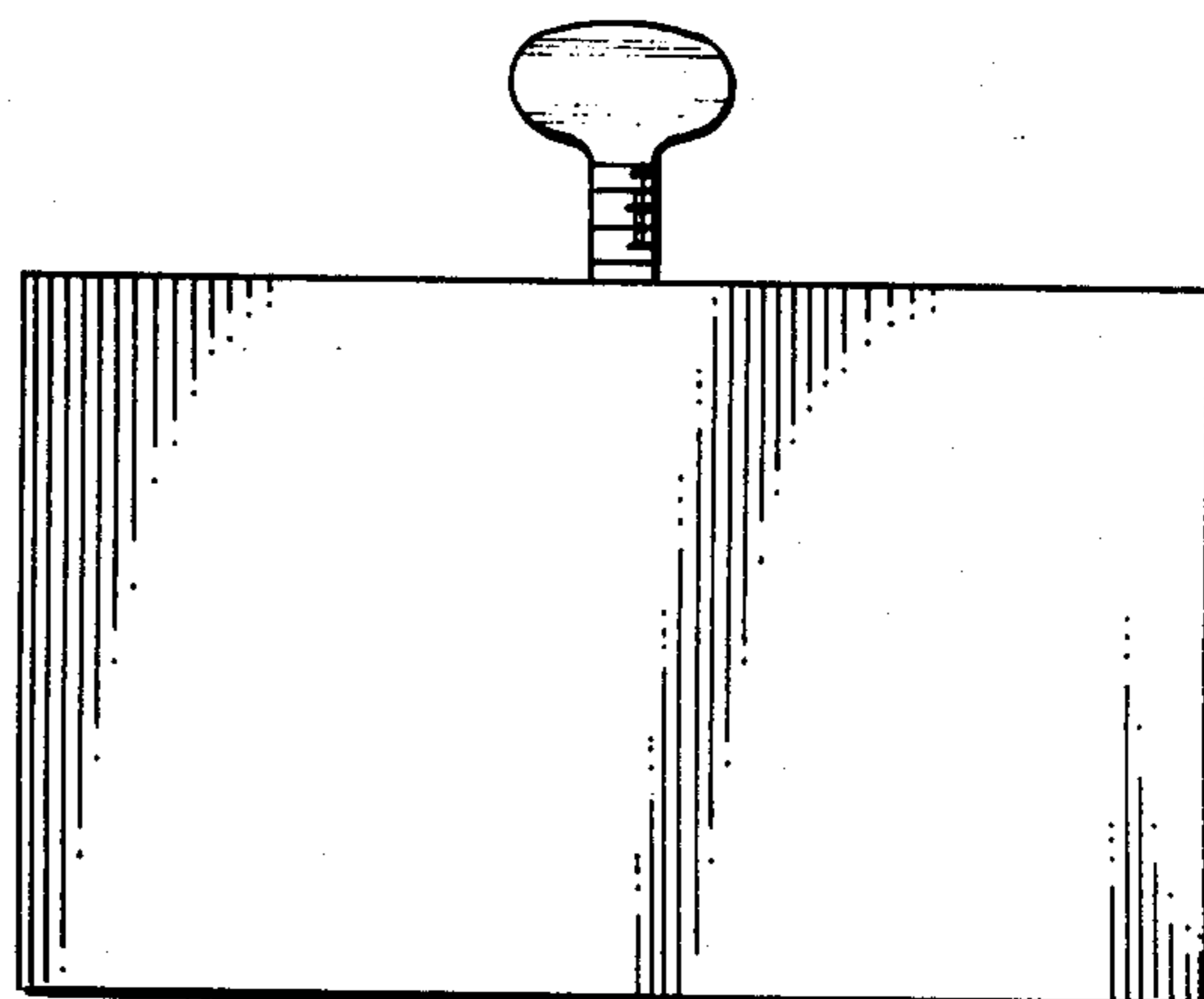

FIG. 6

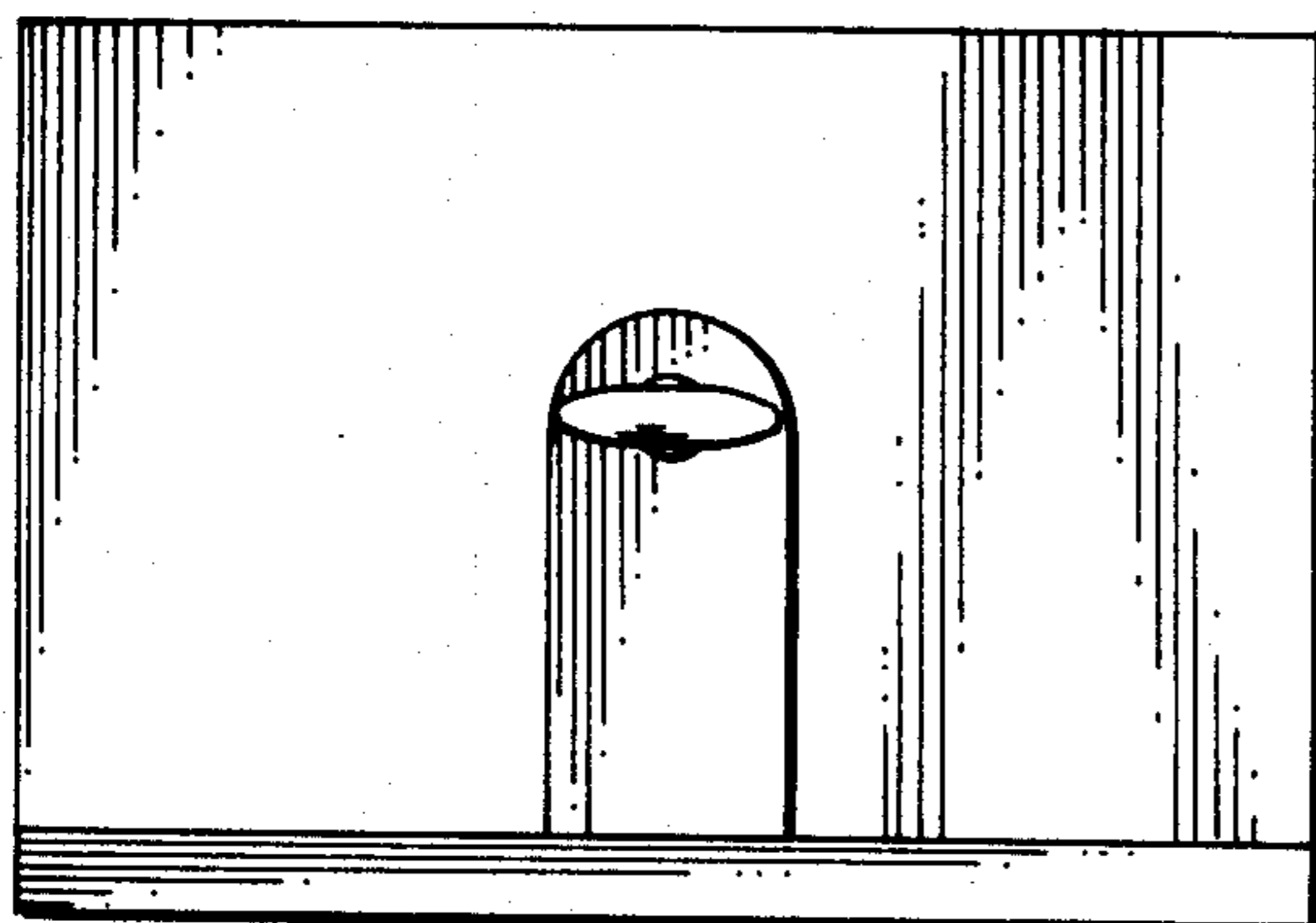

FIG. 7

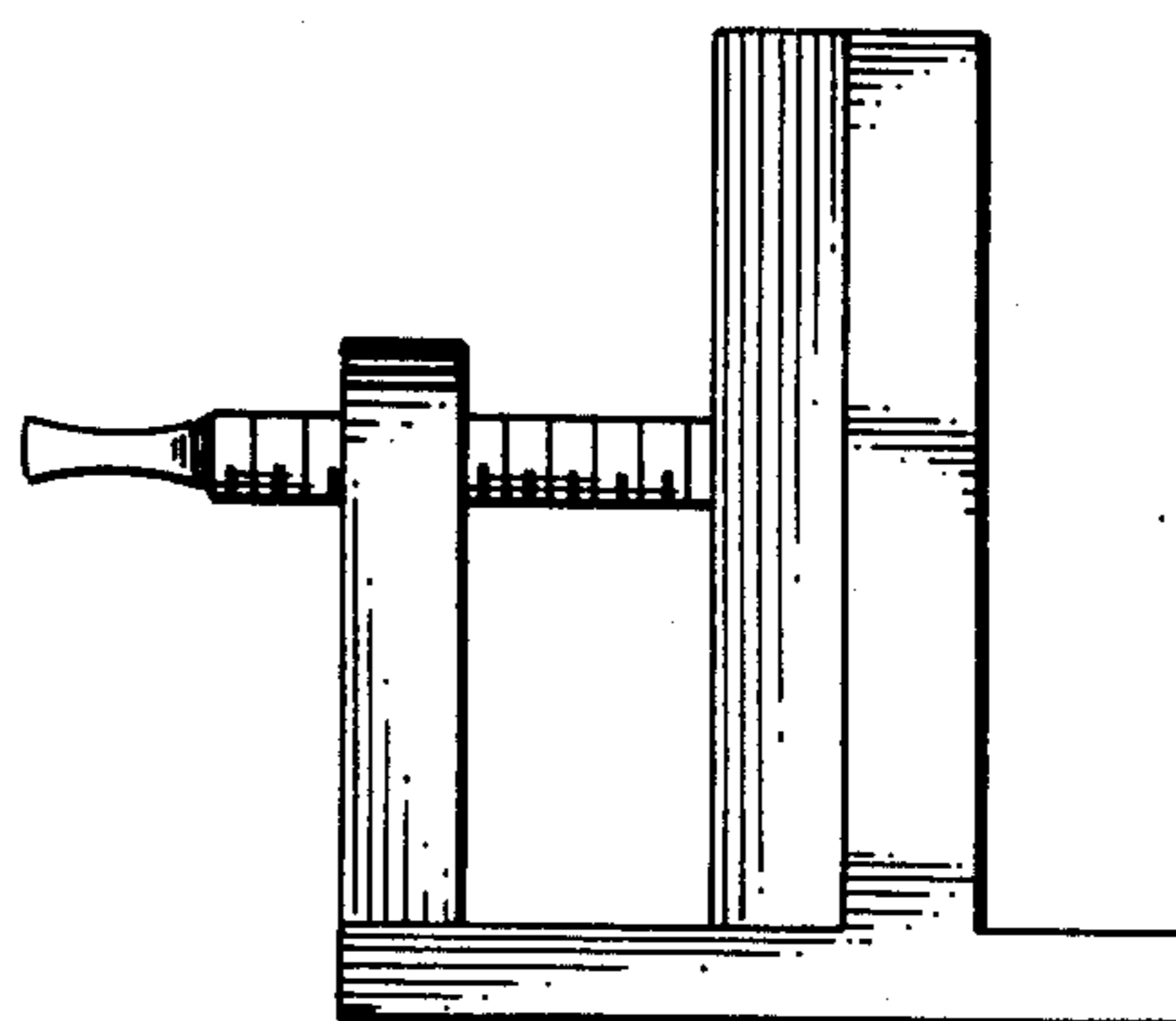

FIG. 8