

[54] **MUSIC CENTER STAND**

[76] **Inventor:** Harry Brodmann, Flat 4, Washington House, 81 Finchfield Rd. West, Finchfield/Wolverhampton, West Midlands, England

[**] **Term:** 14 Years

[21] **Appl. No.:** 783,419

[22] **Filed:** Mar. 31, 1977

[30] **Foreign Application Priority Data**
Jan. 13, 1977 [GB] United Kingdom 978534/77

[51] **Int. Cl.** D14-99
[52] **U.S. Cl.** D14/38; D6/85

[58] **Field of Search** D14/38; D6/85, 29; 248/129, 176, 371, 13; D12/25, 29; 108/59; 280/47.34, 47.35, 79.3, 79.2; 211/71, 126, 133, 134

[56] **References Cited**
U.S. PATENT DOCUMENTS

D. 227,324	6/1973	Rauch	D6/85
D. 239,629	4/1976	Wiener	D14/38
D. 247,034	1/1978	Brodmann	D14/38
D. 247,035	1/1978	Brodmann	D14/38
2,419,422	4/1947	Schulein	248/129

Primary Examiner—Bernard Ansher
Attorney, Agent, or Firm—Melvin R. Jenney

[57] **CLAIM**

The ornamental design for a music center stand, as shown.

DESCRIPTION

FIG. 1 is a perspective view of a music center stand, showing my new design; and FIG. 2 is a rear elevation thereof.

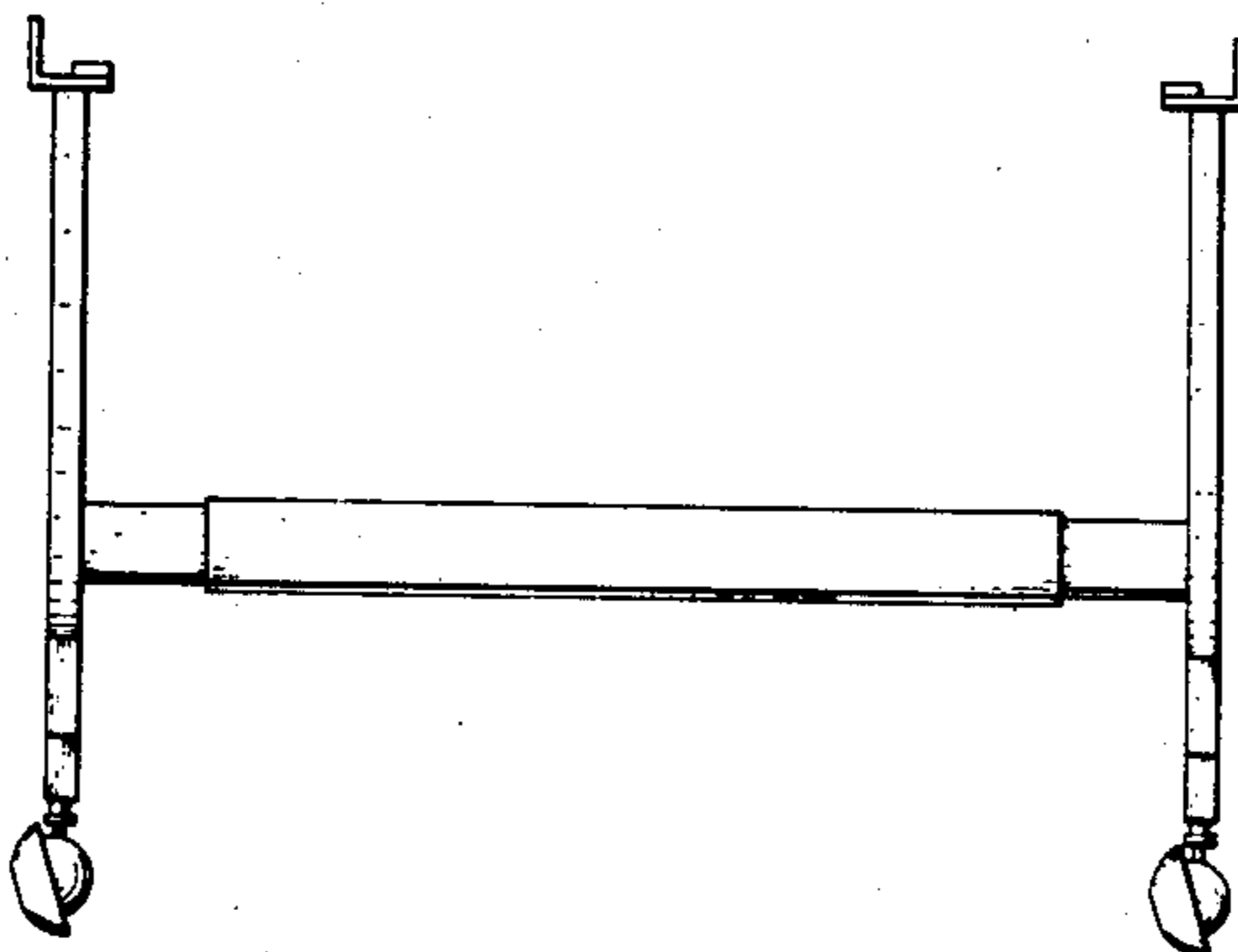
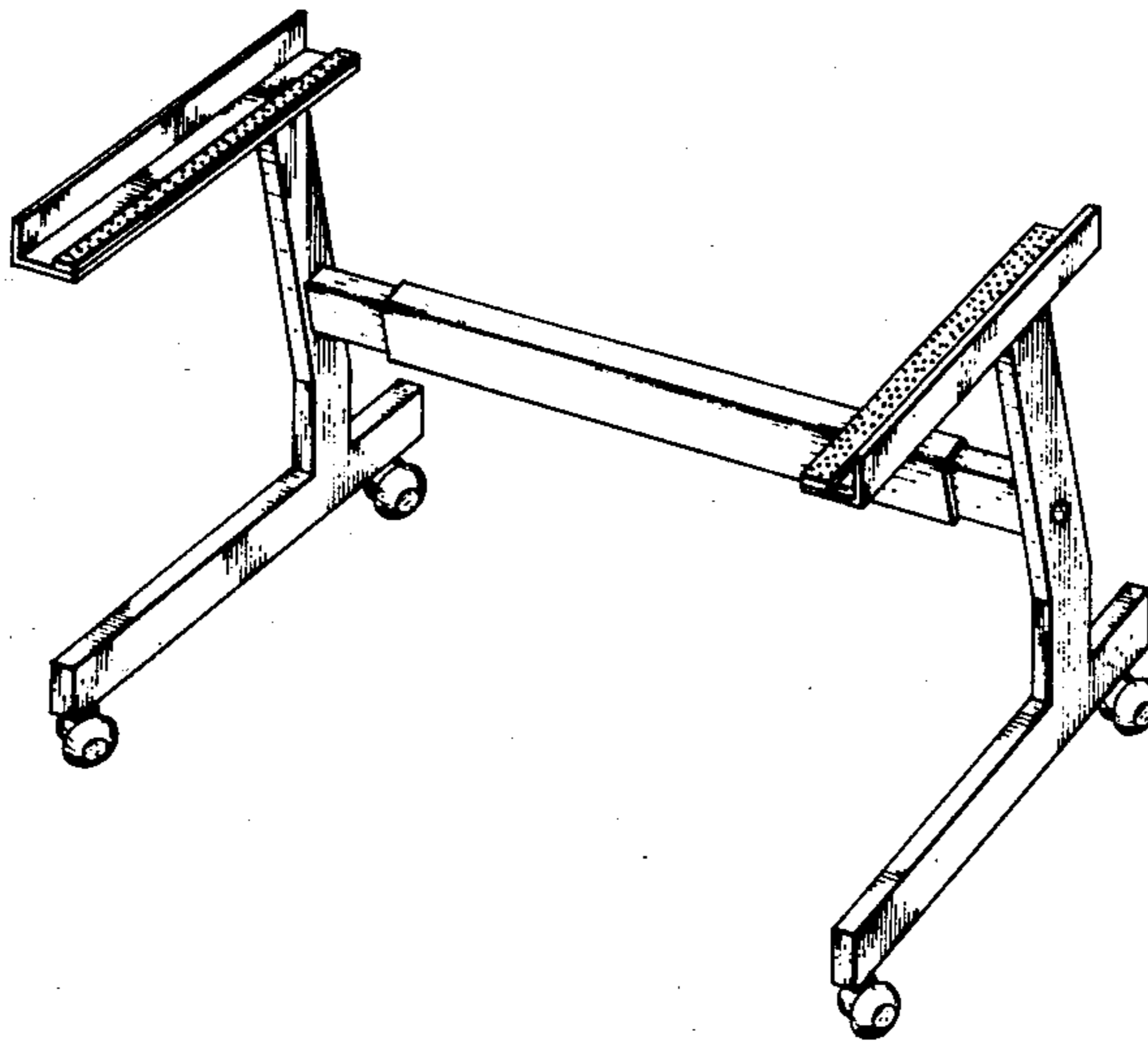

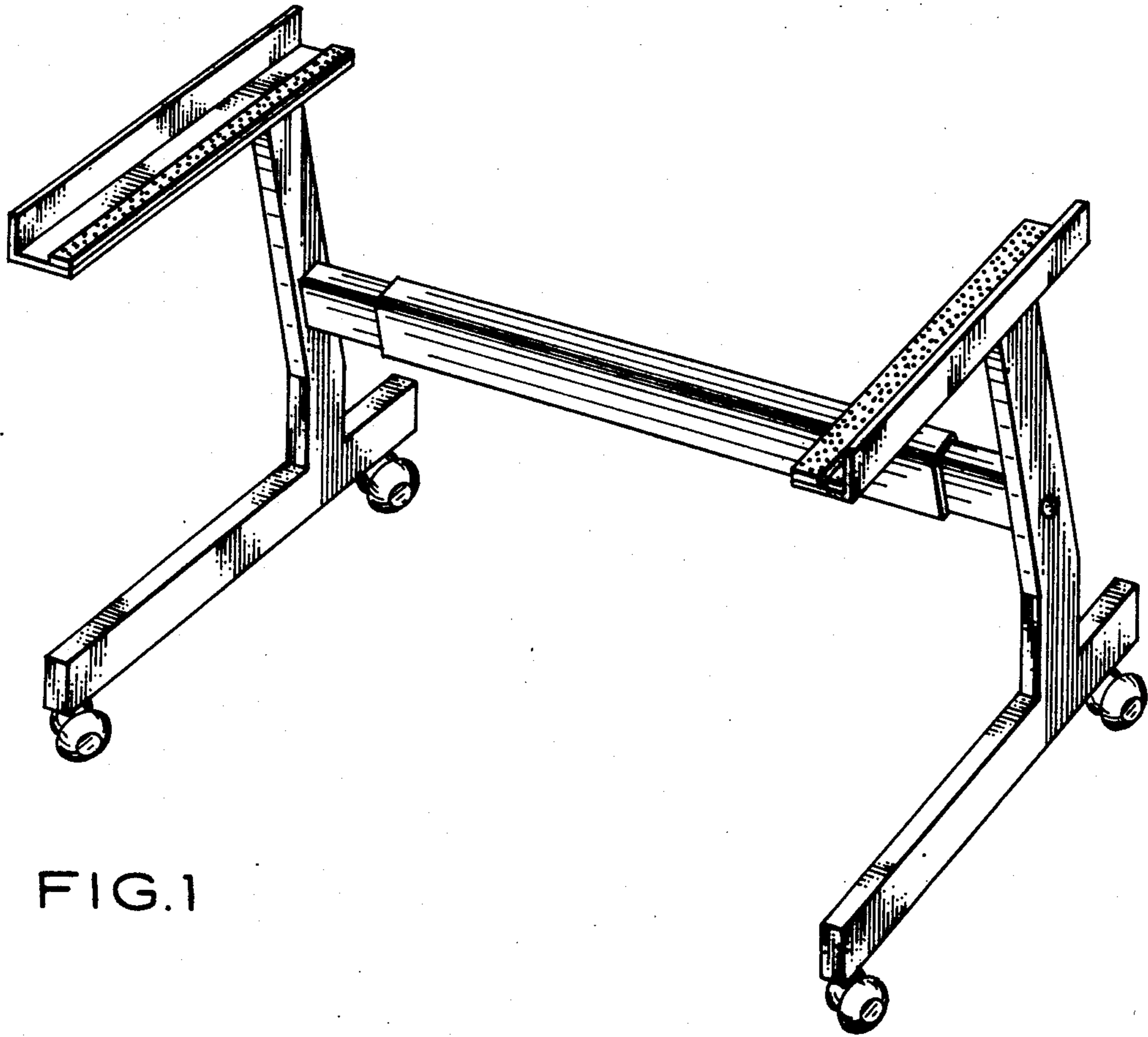

FIG. 1

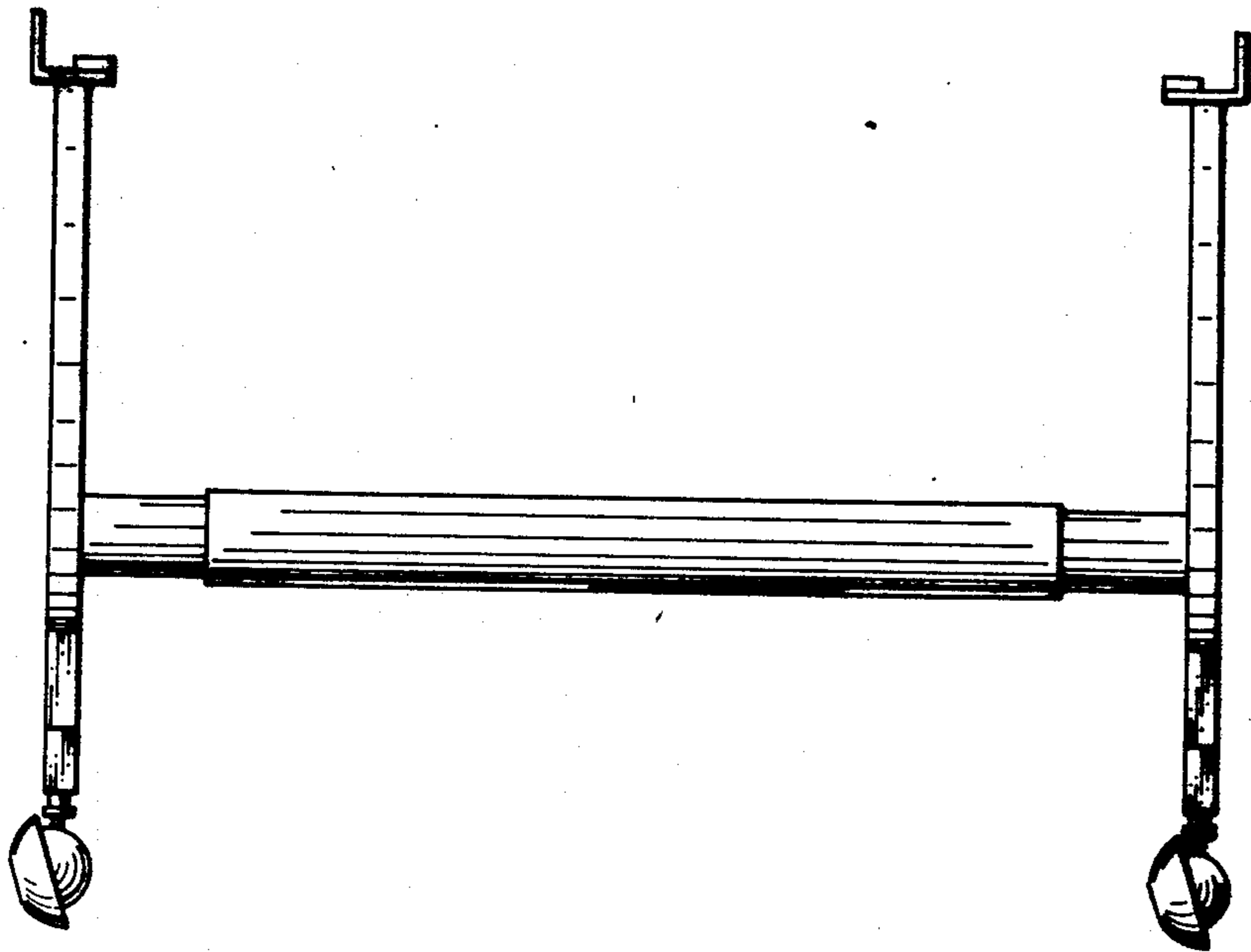

FIG. 2