

[54] MICROTOME BOAT

[76] Inventor: William K. Converse, Jr., P.O. Box 15089, Atlanta, Ga. 30333

[\*\*] Term: 14 Years

[21] Appl. No.: 775,693

[22] Filed: Mar. 9, 1977

[51] Int. Cl. .... D14-02

[52] U.S. Cl. .... D24/7; D24/99; 83/167; 83/915.5

[58] Field of Search ..... D24/7, 99; 83/915.5, 83/176, 167

[56] References Cited

U.S. PATENT DOCUMENTS

D. 199,790	12/1964	Robertson	.....	D24/7
3,103,844	9/1963	Persson	.....	83/167
3,552,733	1/1971	Pickett	.....	83/915.5 X
3,723,226	3/1973	Pfohler	.....	83/915.5 X
3,924,500	12/1975	Kindel	.....	83/915.5 X
4,051,755	10/1977	Raveed	.....	83/915.5

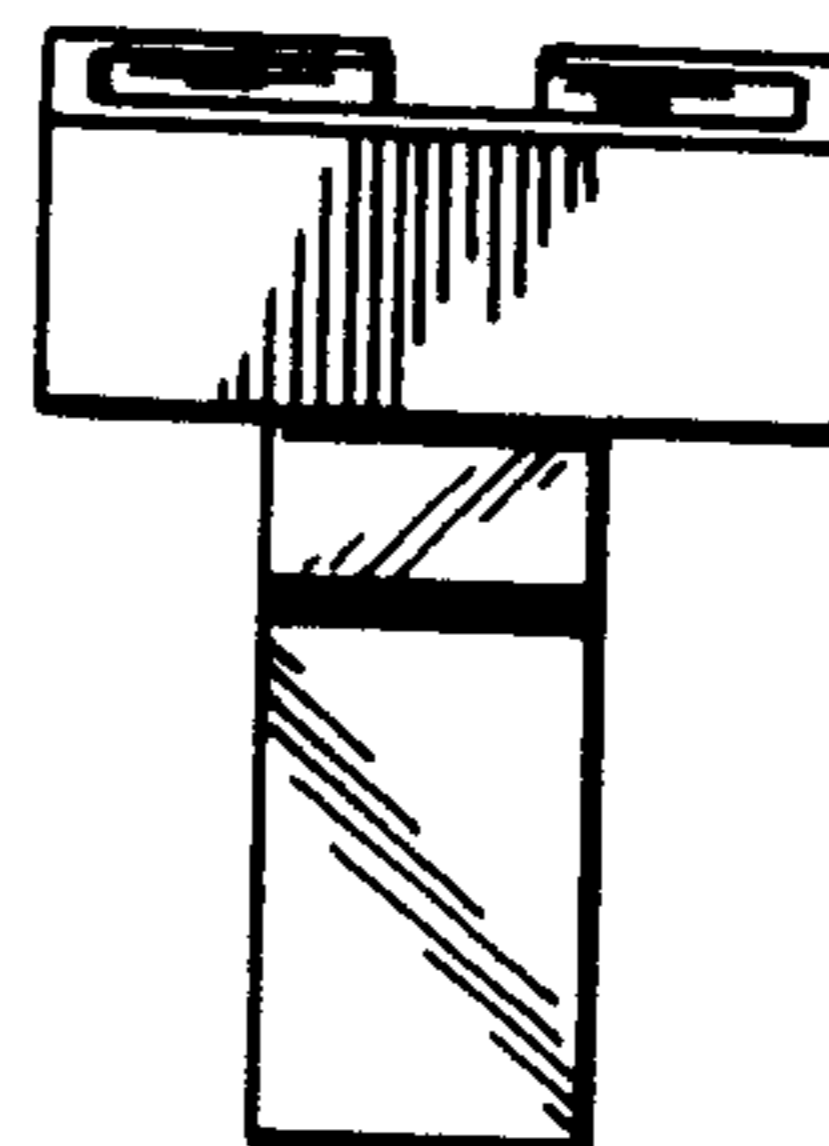
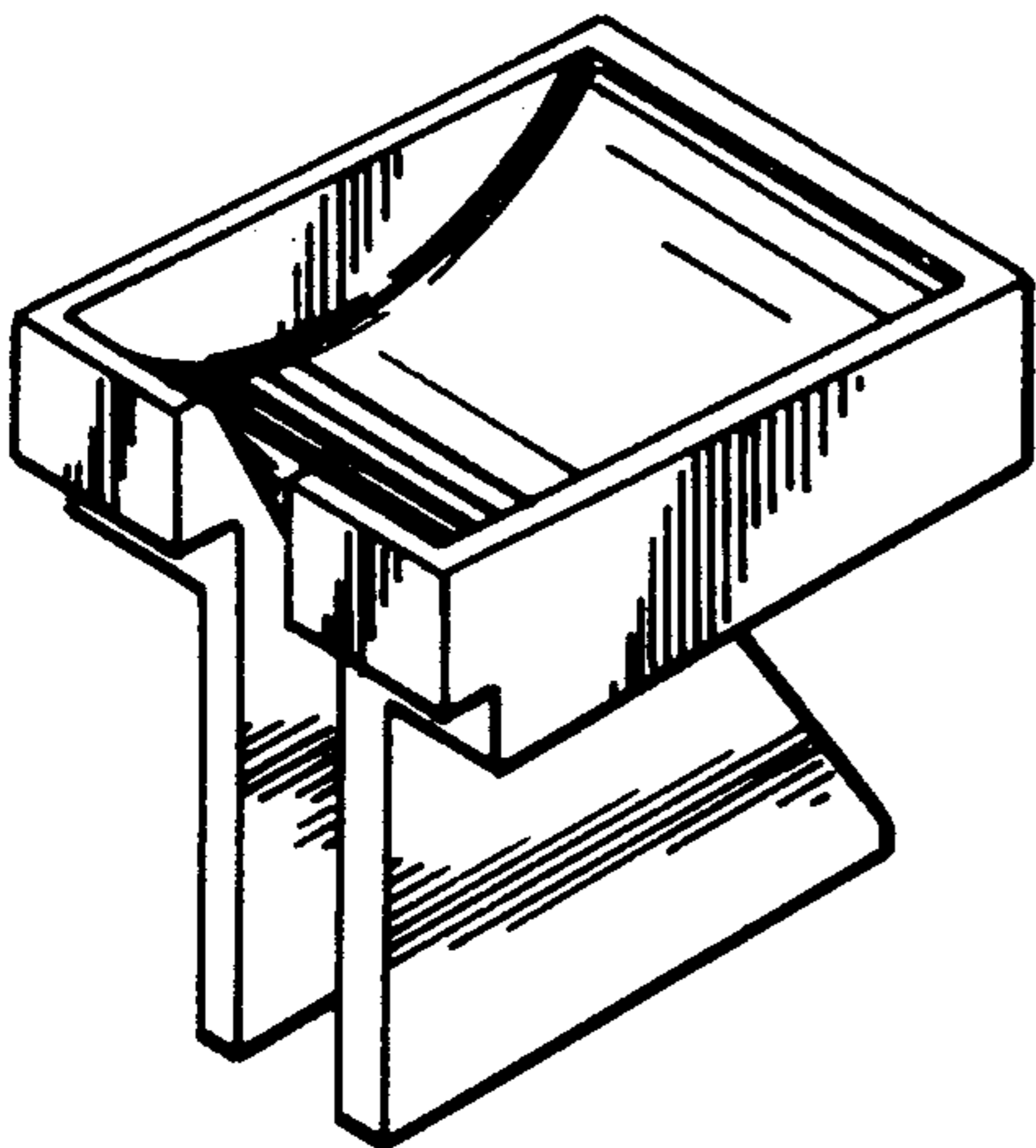
Primary Examiner—Bernard Ansher  
Attorney, Agent, or Firm—Harold D. Jones, Jr.

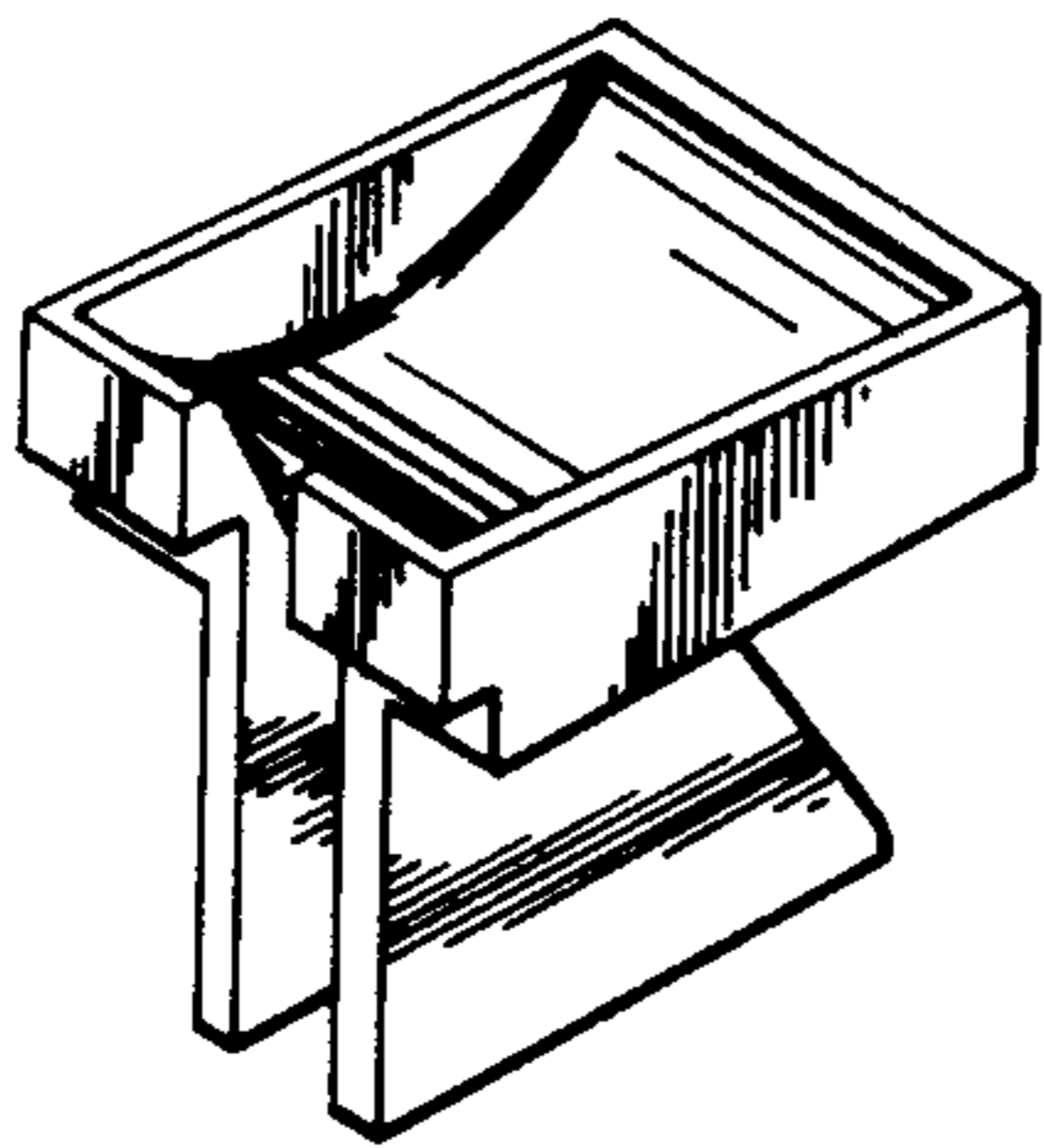
[57] CLAIM

The ornamental design for a microtome boat, substantially as shown and described.

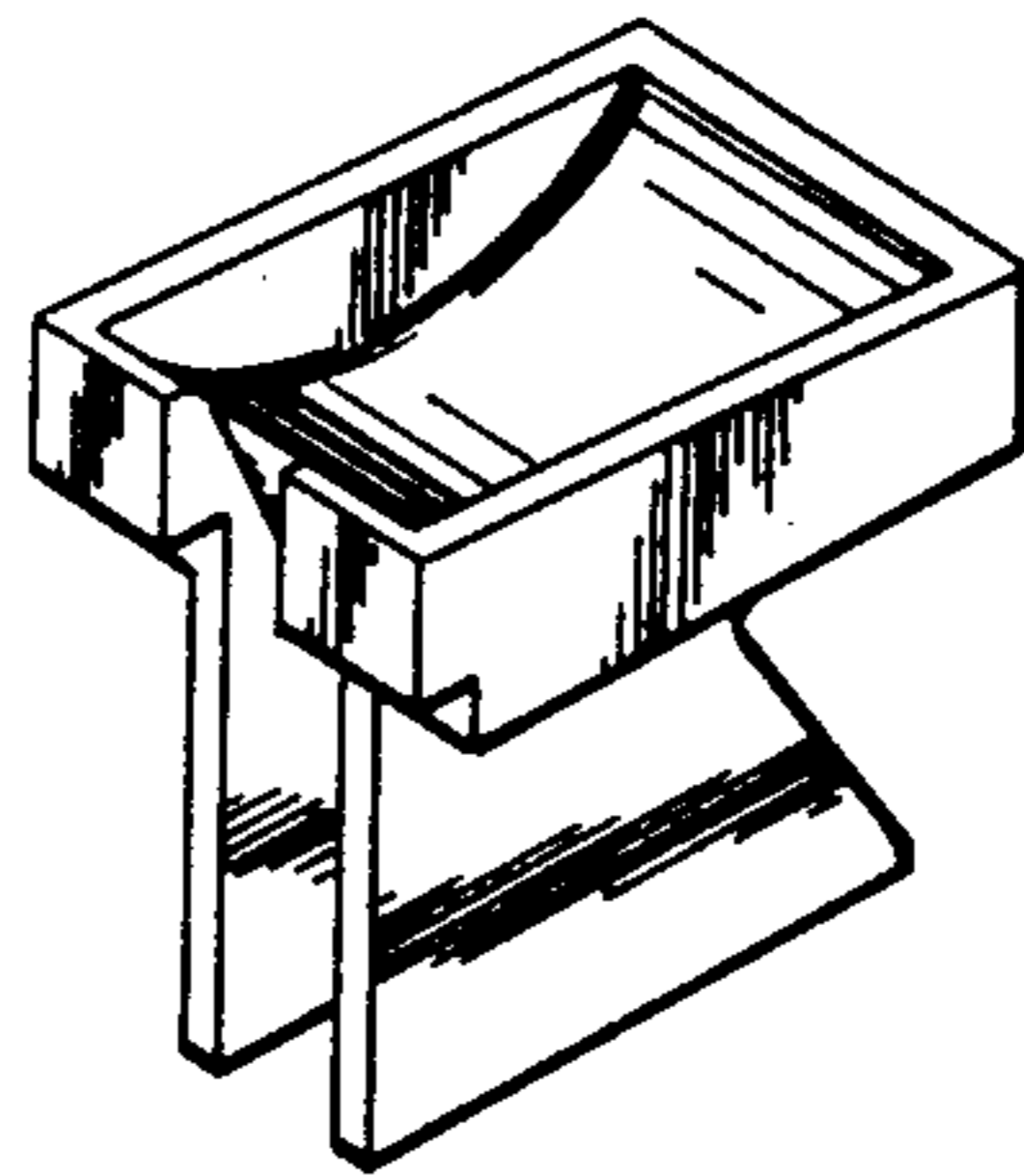
DESCRIPTION

FIG. 1 is a perspective view of the microtome boat, showing the top, left side and front thereof;  
 FIG. 2 is a left side elevation thereof;  
 FIG. 3 is a back view thereof;  
 FIG. 4 is a front elevation thereof;  
 FIG. 5 is a right side elevation thereof;  
 FIG. 6 is a top view thereof;  
 FIG. 7 is a bottom view thereof;  
 FIG. 8 is a perspective view of a first modification of the microtome boat, showing the top, left side and front thereof;  
 FIG. 9 is a left side elevation thereof;  
 FIG. 10 is a back view thereof;  
 FIG. 11 is a front elevation thereof;  
 FIG. 12 is a right side elevation thereof;  
 FIG. 13 is a top view thereof;  
 FIG. 14 is a bottom view thereof;  
 FIG. 15 is a perspective view of a second modification of the microtome boat, showing the top, left side and front thereof;  
 FIG. 16 is a left side elevation thereof;  
 FIG. 17 is a back view thereof;  
 FIG. 18 is a front elevation thereof;  
 FIG. 19 is a right side elevation thereof;  
 FIG. 20 is a top view thereof;  
 FIG. 21 is a bottom view thereof;  
 FIG. 22 is a perspective view of a third modified microtome boat, showing the top, left side and front thereof;  
 FIG. 23 is a left side elevation thereof;  
 FIG. 24 is a back view thereof;  
 FIG. 25 is a front elevation thereof;  
 FIG. 26 is a right side elevation thereof;  
 FIG. 27 is a top view thereof;  
 FIG. 28 is a bottom view thereof.

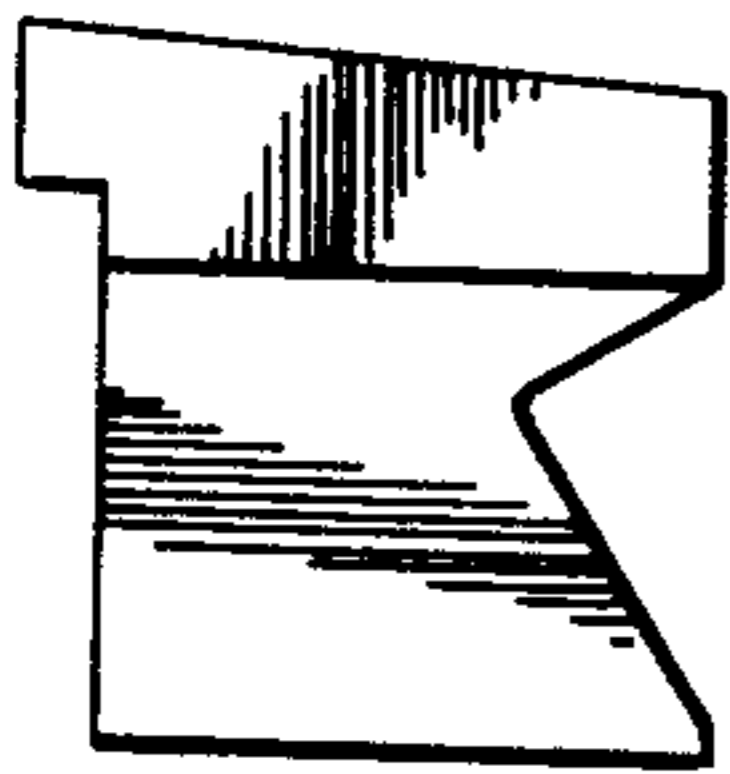




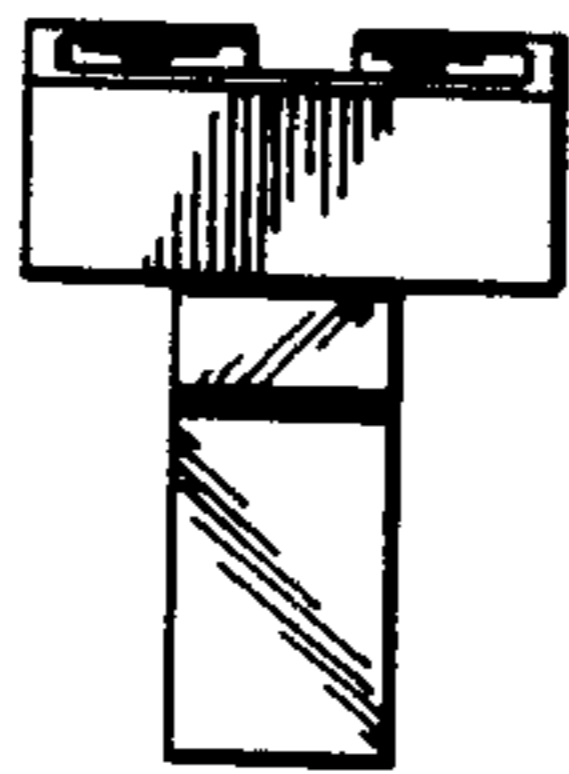
**FIG 1**



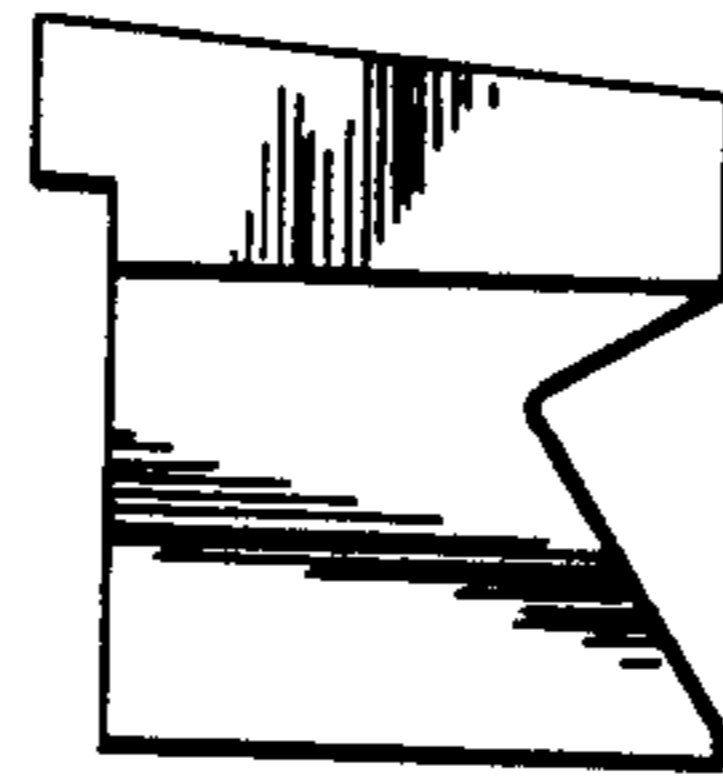
**FIG 8**



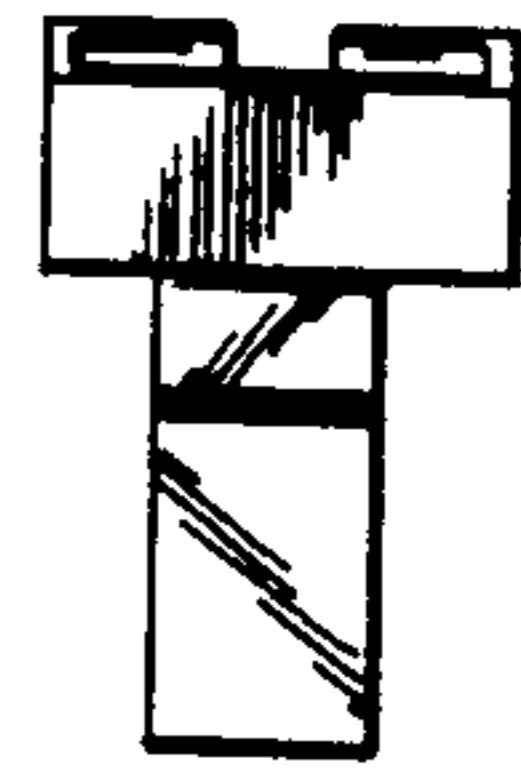
**FIG 2**



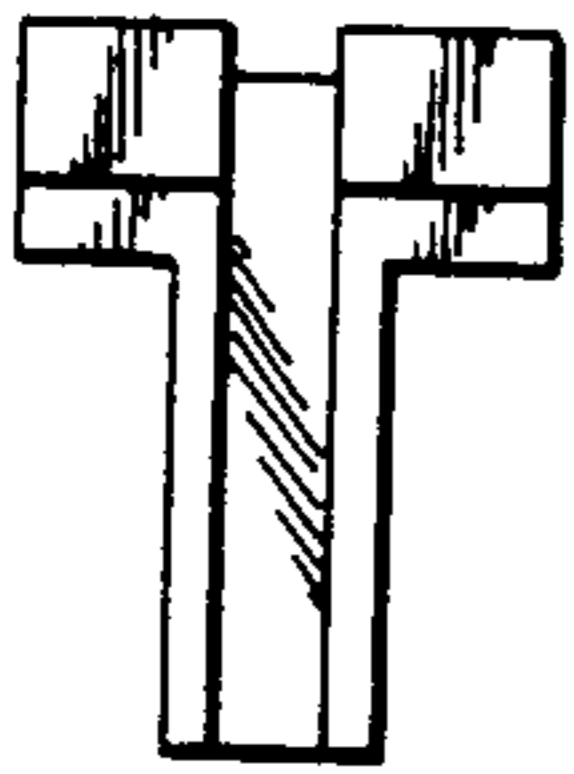
**FIG 3**



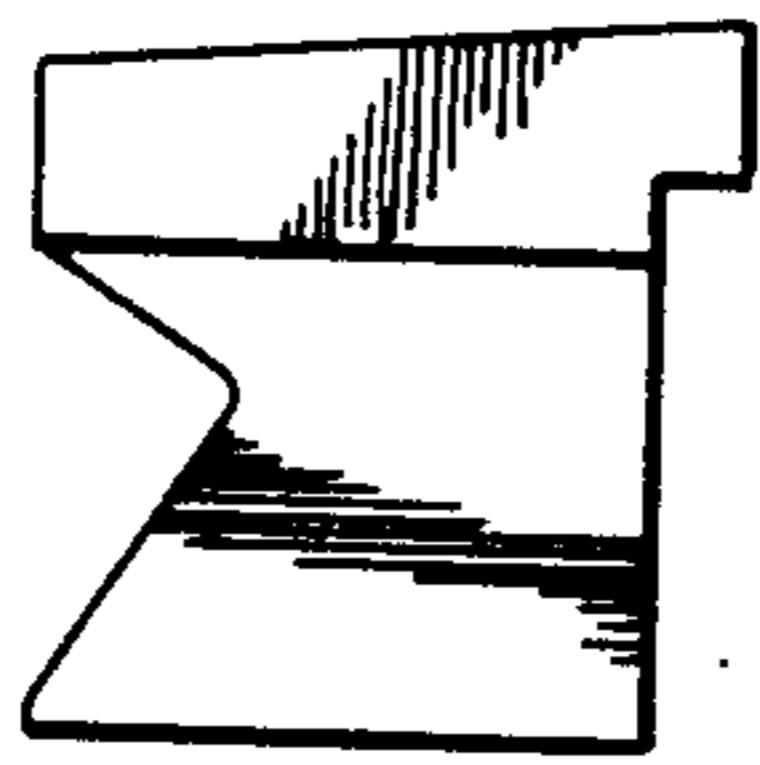
**FIG 9**



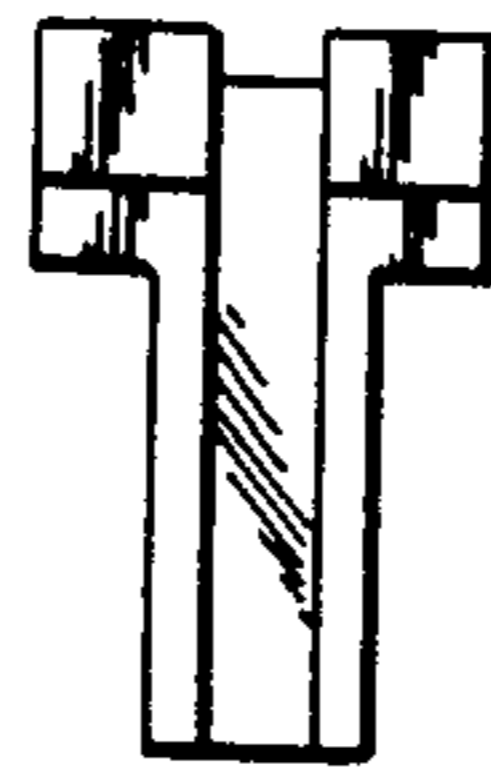
**FIG 10**



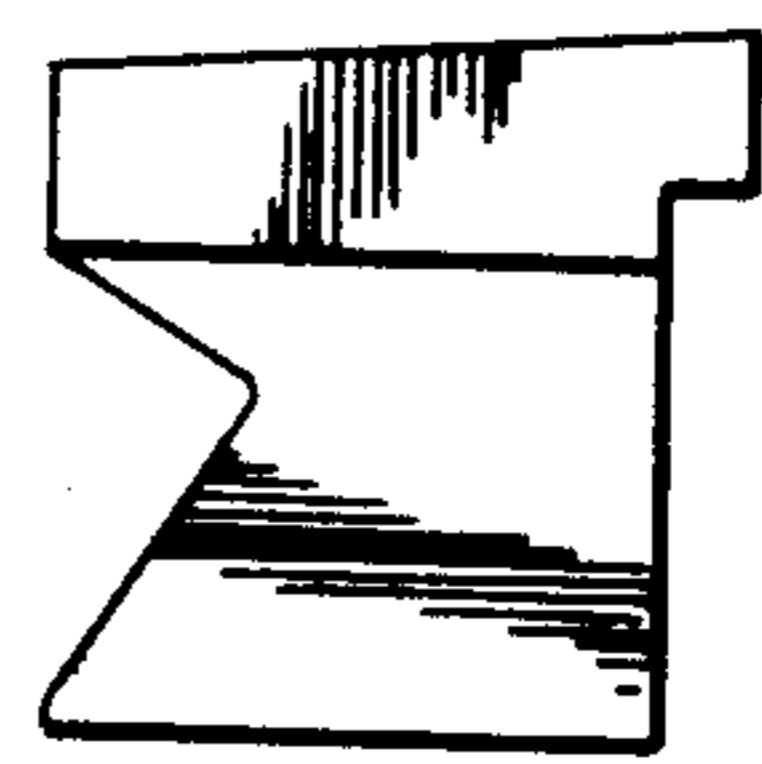
**FIG 4**



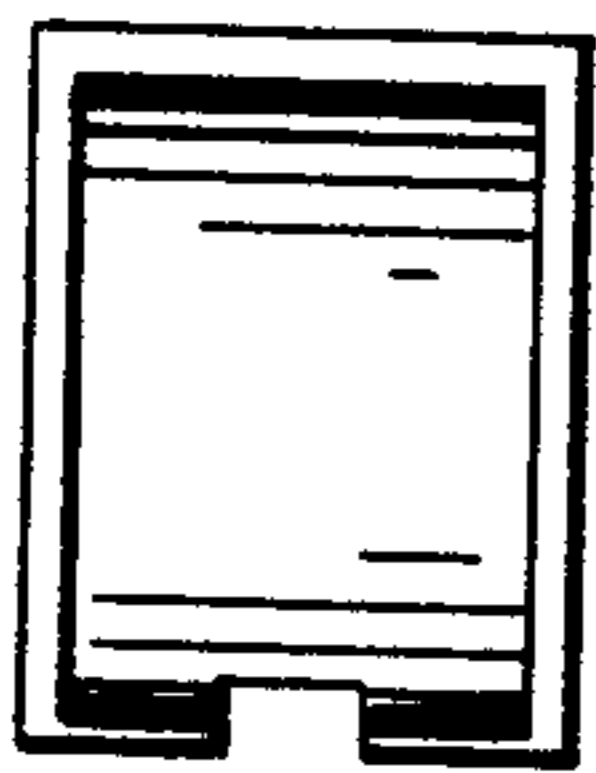
**FIG 5**



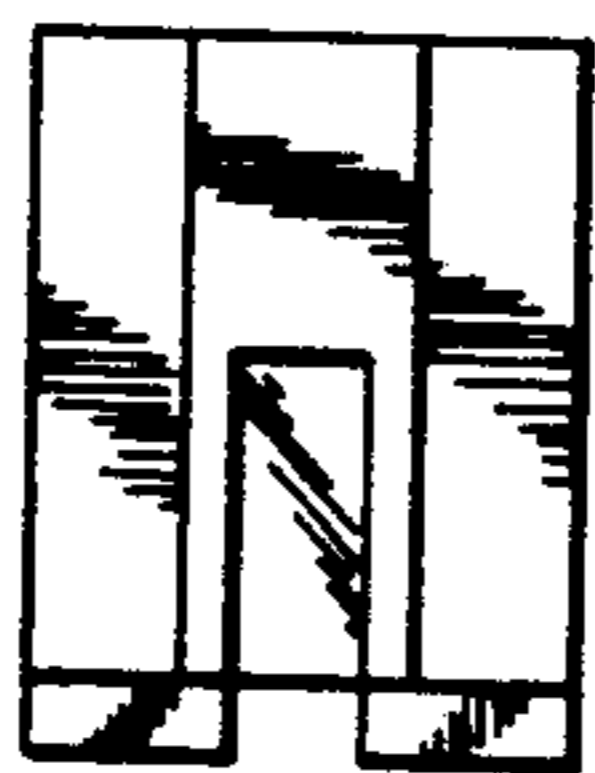
**FIG 11**



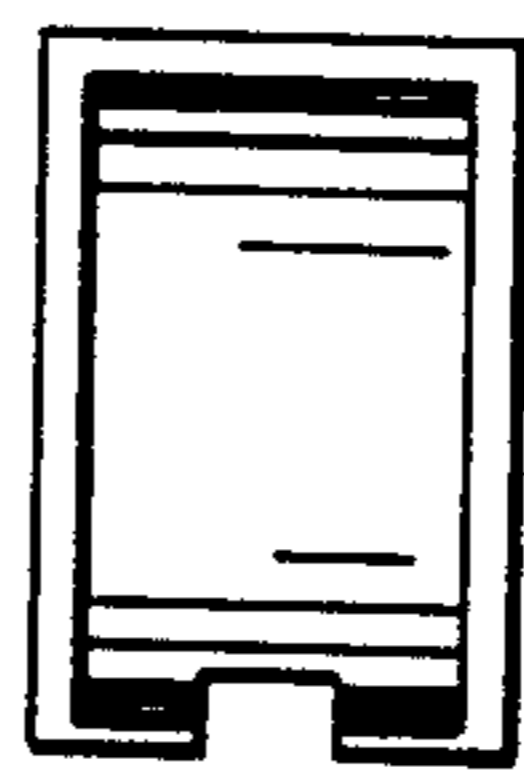
**FIG 12**



**FIG 6**



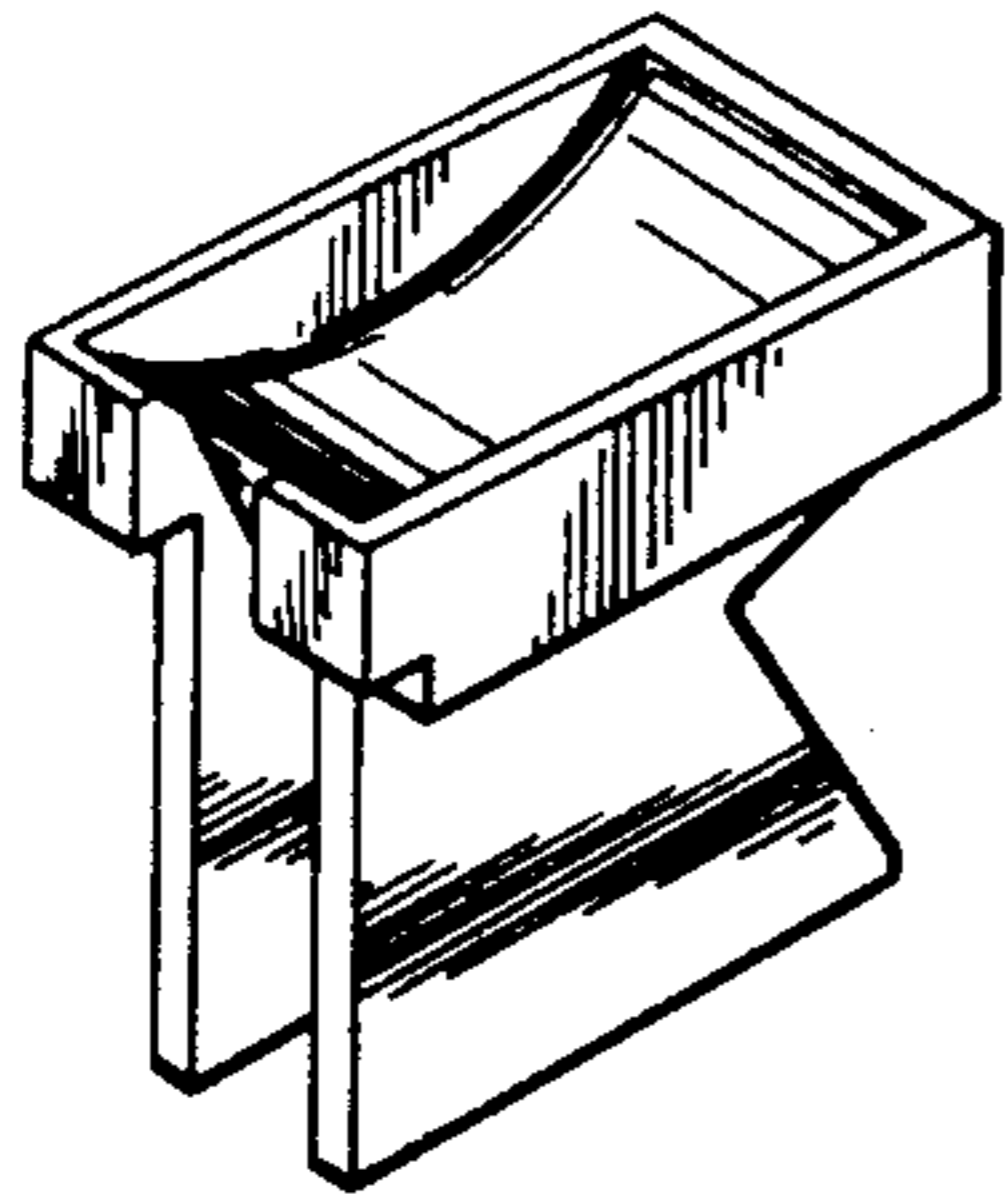
**FIG 7**



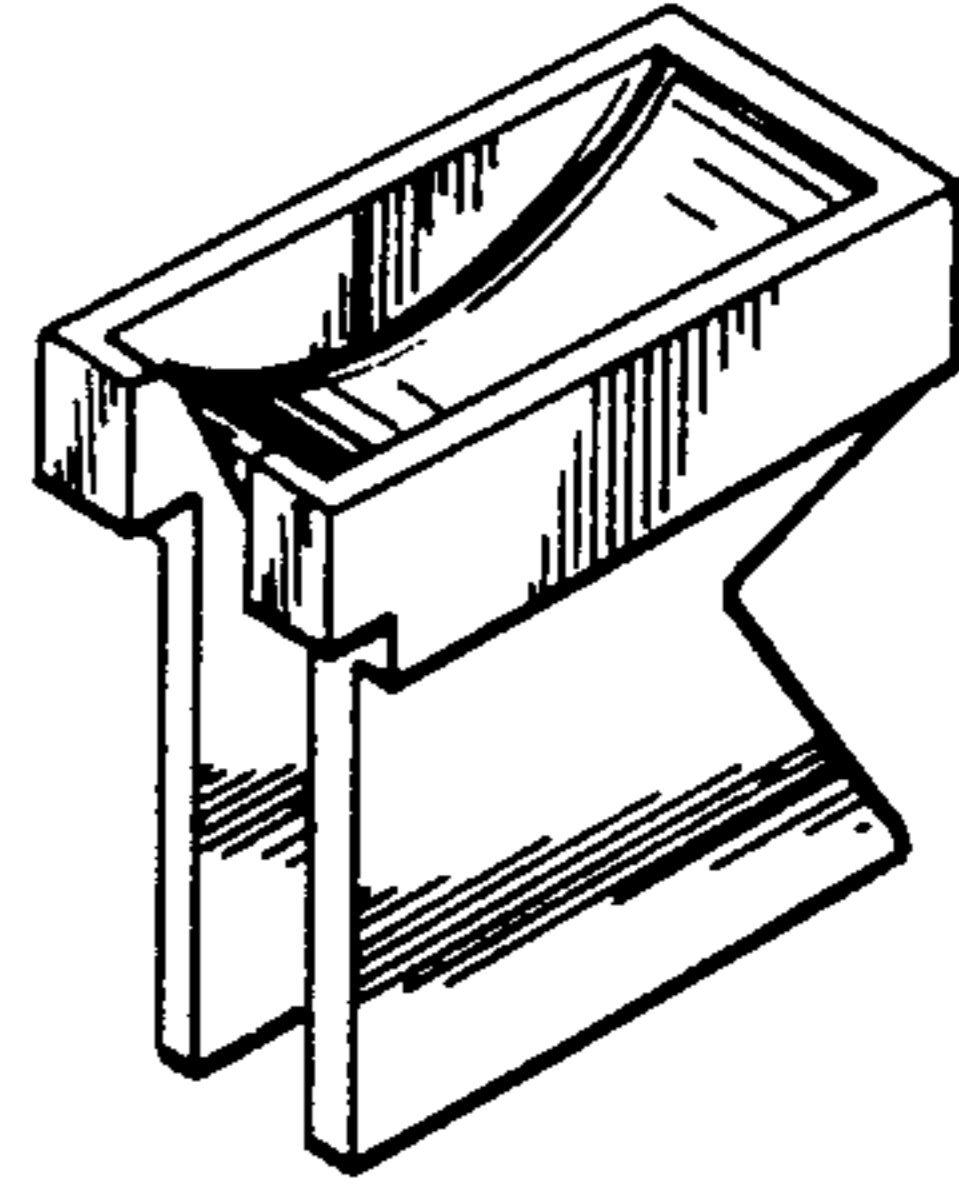
**FIG 13**



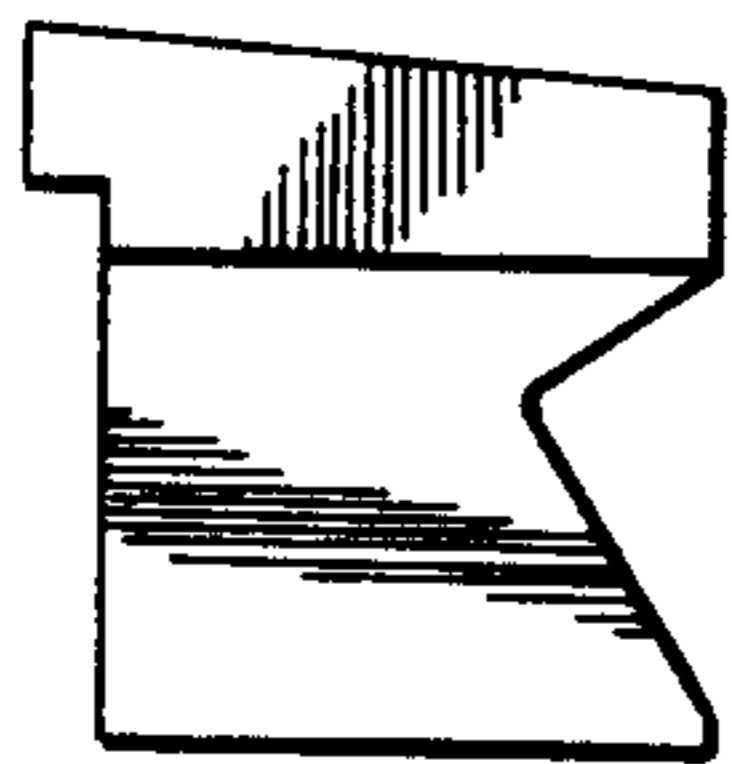
**FIG 14**



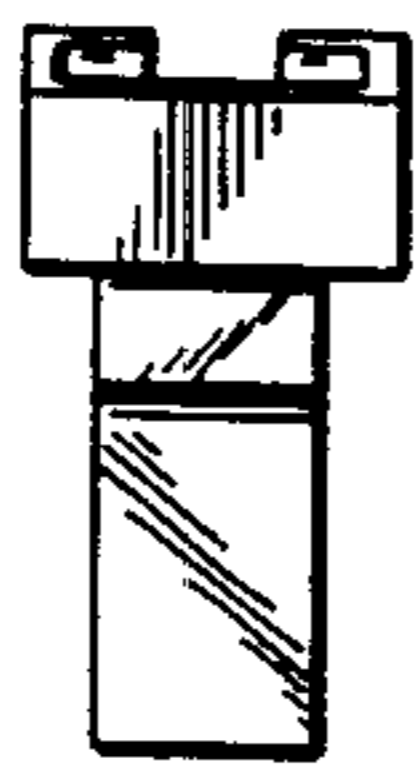
**FIG 15**



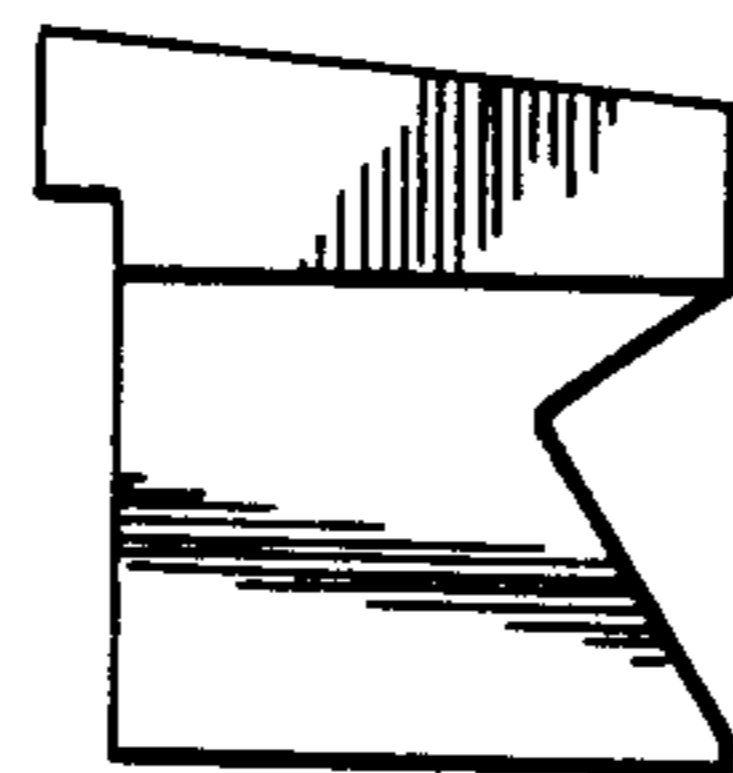
**FIG 22**



**FIG 16**



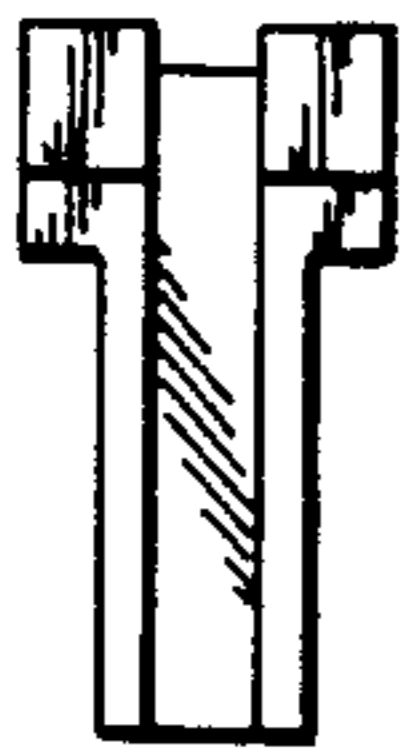
**FIG 17**



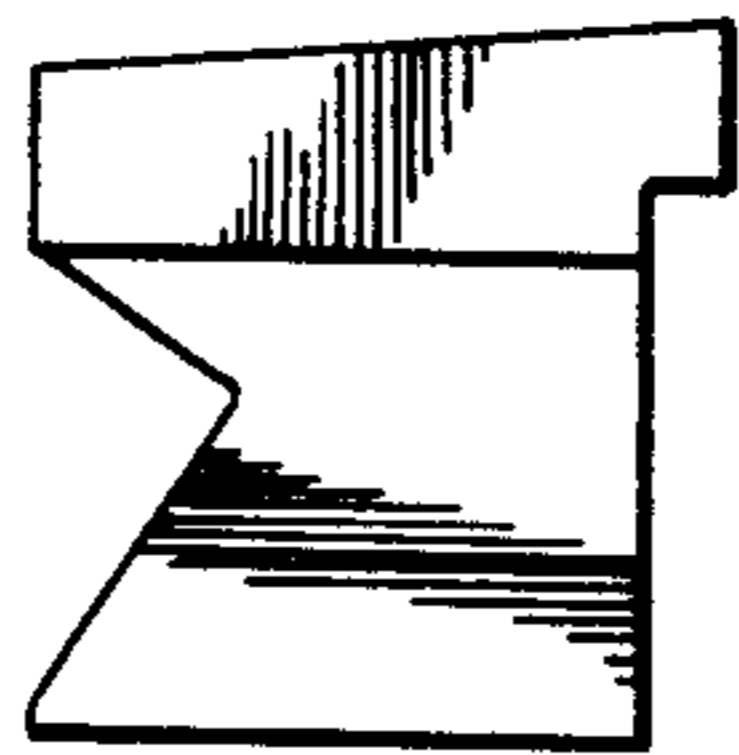
**FIG 23**



**FIG 24**



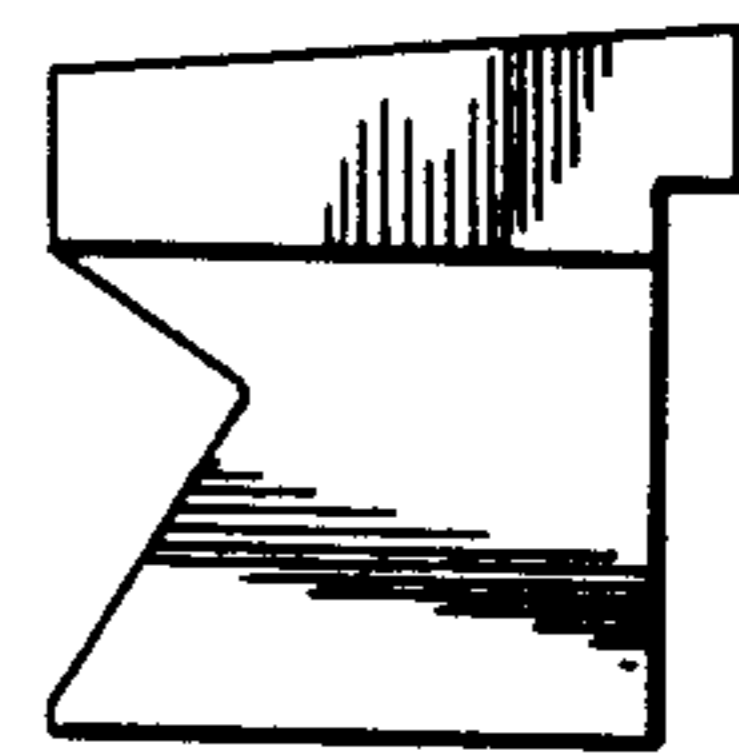
**FIG 18**



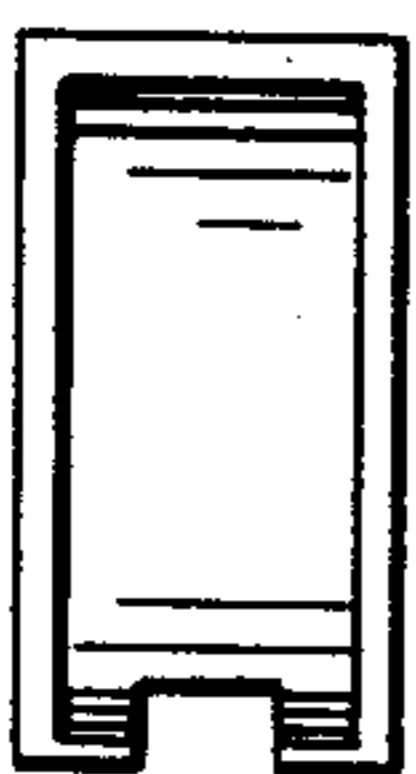
**FIG 19**



**FIG 25**



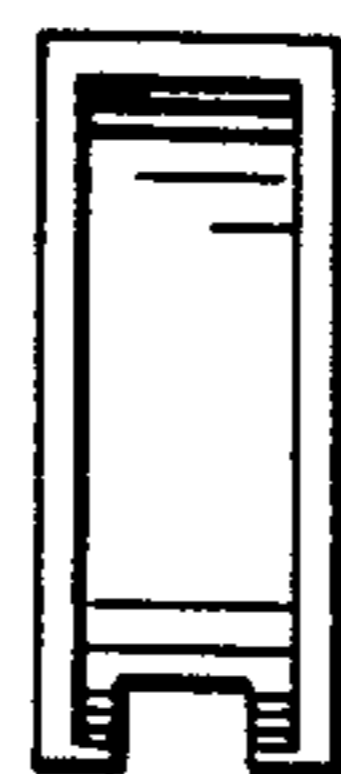
**FIG 26**



**FIG 20**



**FIG 21**



**FIG 27**



**FIG 28**