

[54] MULTIPLICITY PUMP VEHICLE

[76] Inventor: Howard I. Smith, 9989 East Ave., Hesperia, Calif. 92345

[\*\*] Term: 14 Years

[21] Appl. No.: 775,568

[22] Filed: Mar. 7, 1977

[51] Int. Cl. .... D15-02; D15-04

[52] U.S. Cl. .... D15/7; D15/27; D12/102

[58] Field of Search ..... D15/19, 27, 7-9; D12/102, 95; 239/146-147, 157, 172; 280/5 R, 5 B, 5 C, 5 E, 5 F; 222/626, 627

[56] References Cited

U.S. PATENT DOCUMENTS

D. 208,538 9/1967 Aiello ..... D15/27

Primary Examiner—James M. Gandy  
Attorney, Agent, or Firm—Francis X. Lojacono, Sr.

[57] CLAIM

The ornamental design for a multiplicity pump vehicle, as shown.

DESCRIPTION

FIG. 1 is a top plan view of a multiplicity pump vehicle showing my new design; FIG. 2 is a right side elevational view thereof; FIG. 3 is a left side elevational view thereof; FIG. 4 is a rear elevational view thereof; and FIG. 5 is a front elevational view thereof.

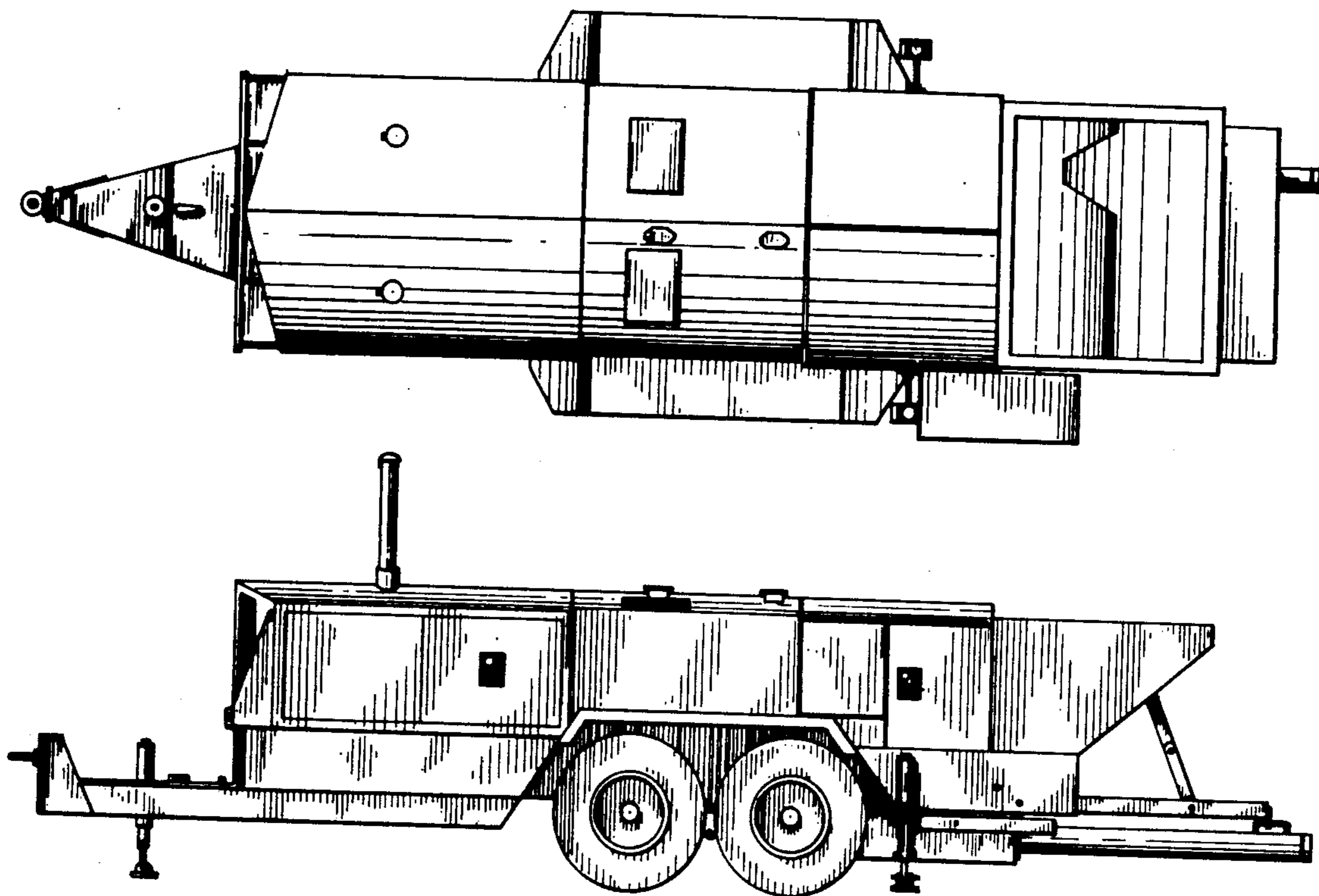

FIG. 1

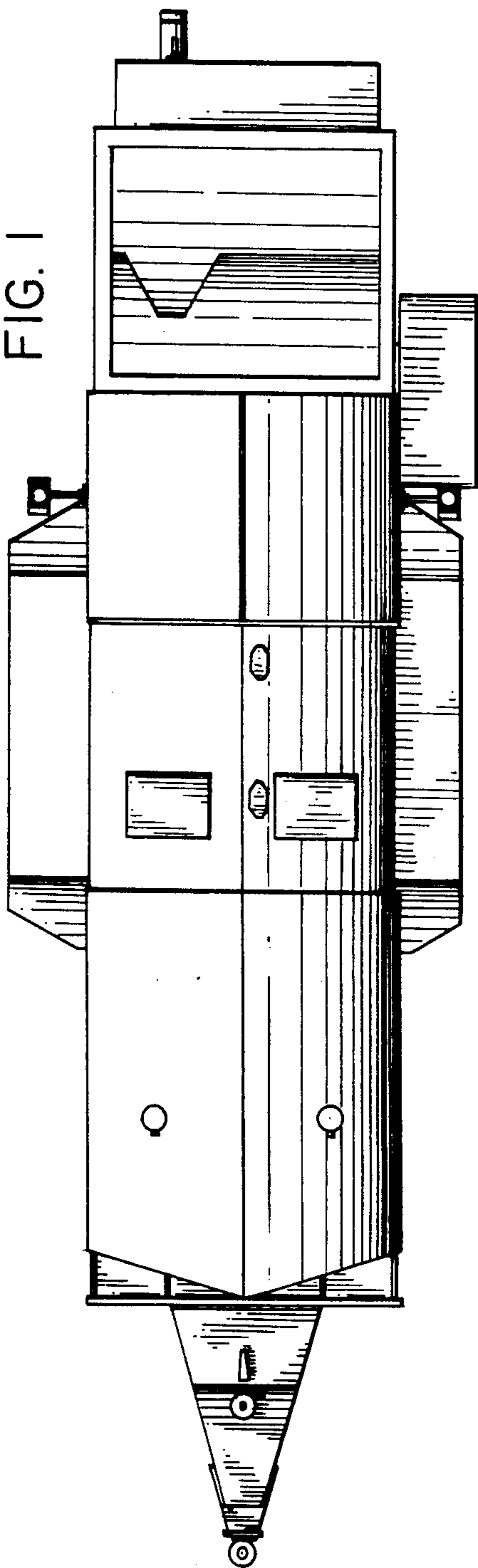
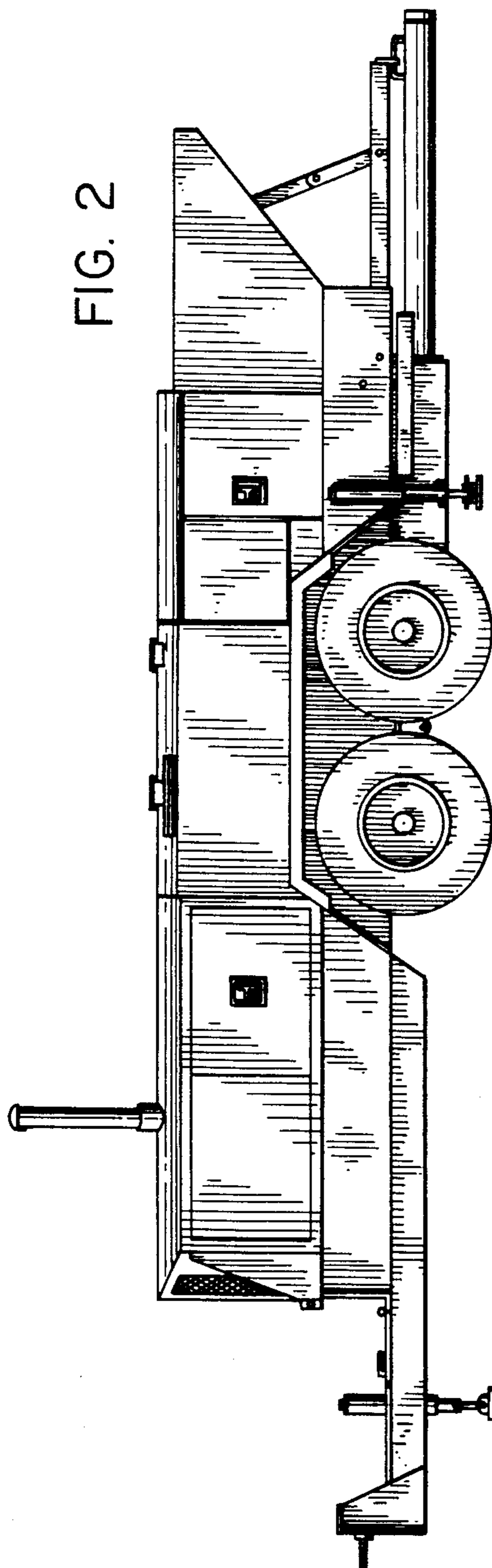

FIG. 2



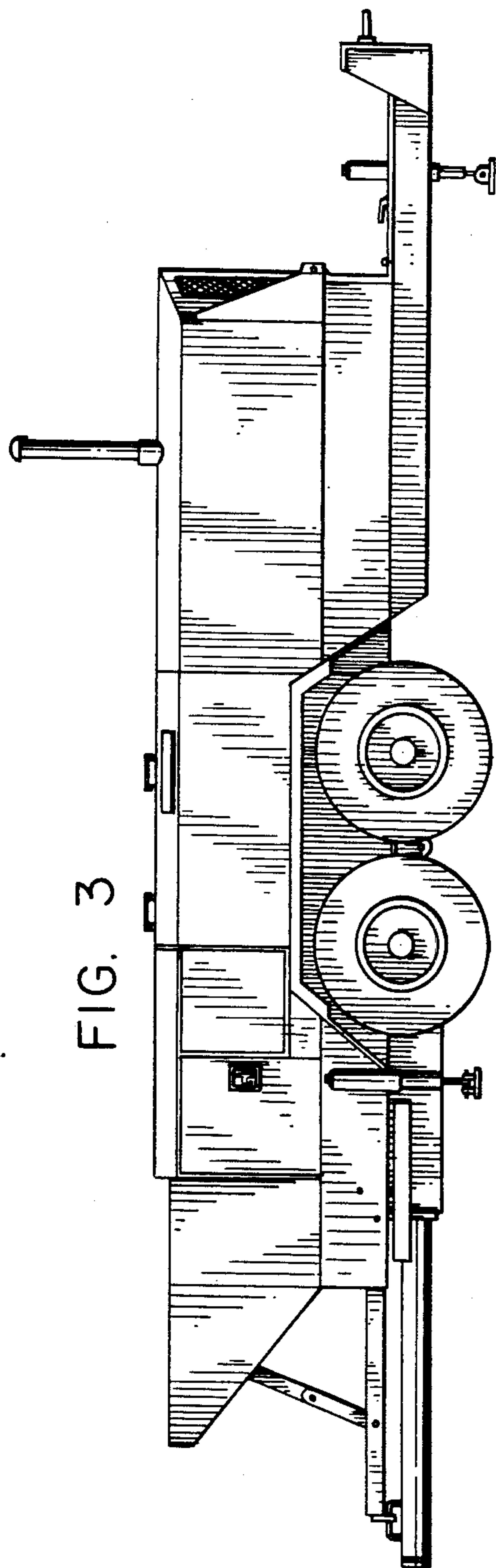

FIG. 3

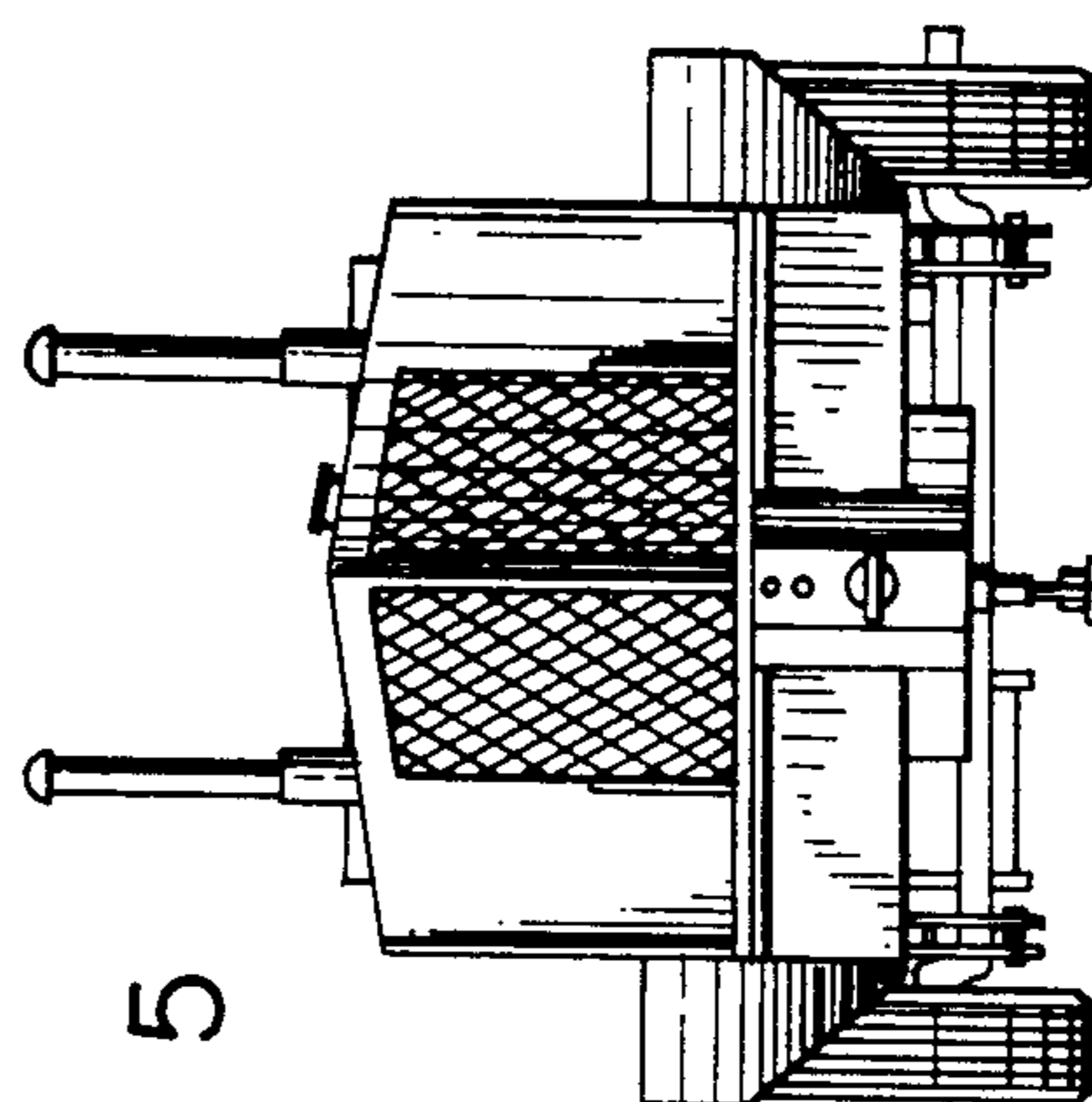

FIG. 5

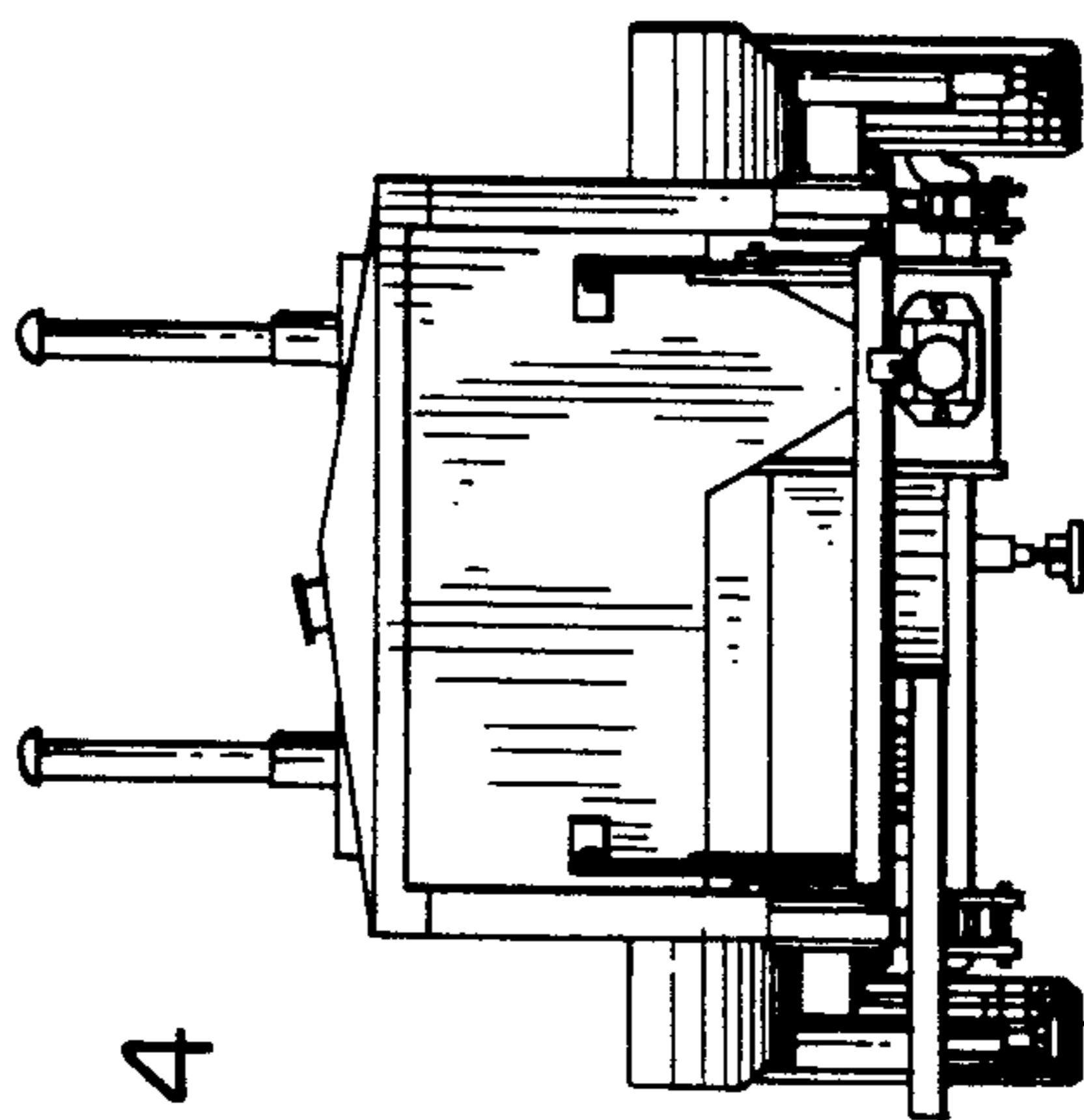

FIG. 4