

[54] VEHICLE FRAME

[75] Inventors: George C. Moore; Jodele Moore, both of Las Vegas, Nev.; James M. Tipke, Spokane, Wash.

[73] Assignee: Western Rickshaws, Inc., Las Vegas, Nev.

[**] Term: 14 Years

[21] Appl. No.: 783,972

[22] Filed: Apr. 4, 1977

[51] Int. Cl. D12-11

[52] U.S. Cl. D12/85; D12/110; D12/112

[58] Field of Search D12/85, 110, 112; 180/27, 26 R

[56] References Cited

U.S. PATENT DOCUMENTS

D. 33,043 7/1900 Turner D12/85

D. 35,713	2/1902	Turner	D12/85
D. 59,359	10/1921	Kawanami	D12/85
3,004,619	10/1961	Straussler	D12/85

OTHER PUBLICATIONS

Industrial Equipment News, 12/73, p. 11, Three Wheeled Vehicle, top right side of page.

Primary Examiner—James M. Gandy

Attorney, Agent, or Firm—Carlisle M. Moore

[57]

CLAIM

The ornamental design for a vehicle frame, substantially as shown.

DESCRIPTION

FIG. 1 is a top, front isometric view of a vehicle frame showing our new design;

FIG. 2 is a side elevational view thereof, the opposite side being a mirror image of the side shown herein;

FIG. 3 is a bottom, rear isometric view thereof;

FIG. 4 is a front elevational view thereof; and

FIG. 5 is a rear elevational view thereof.

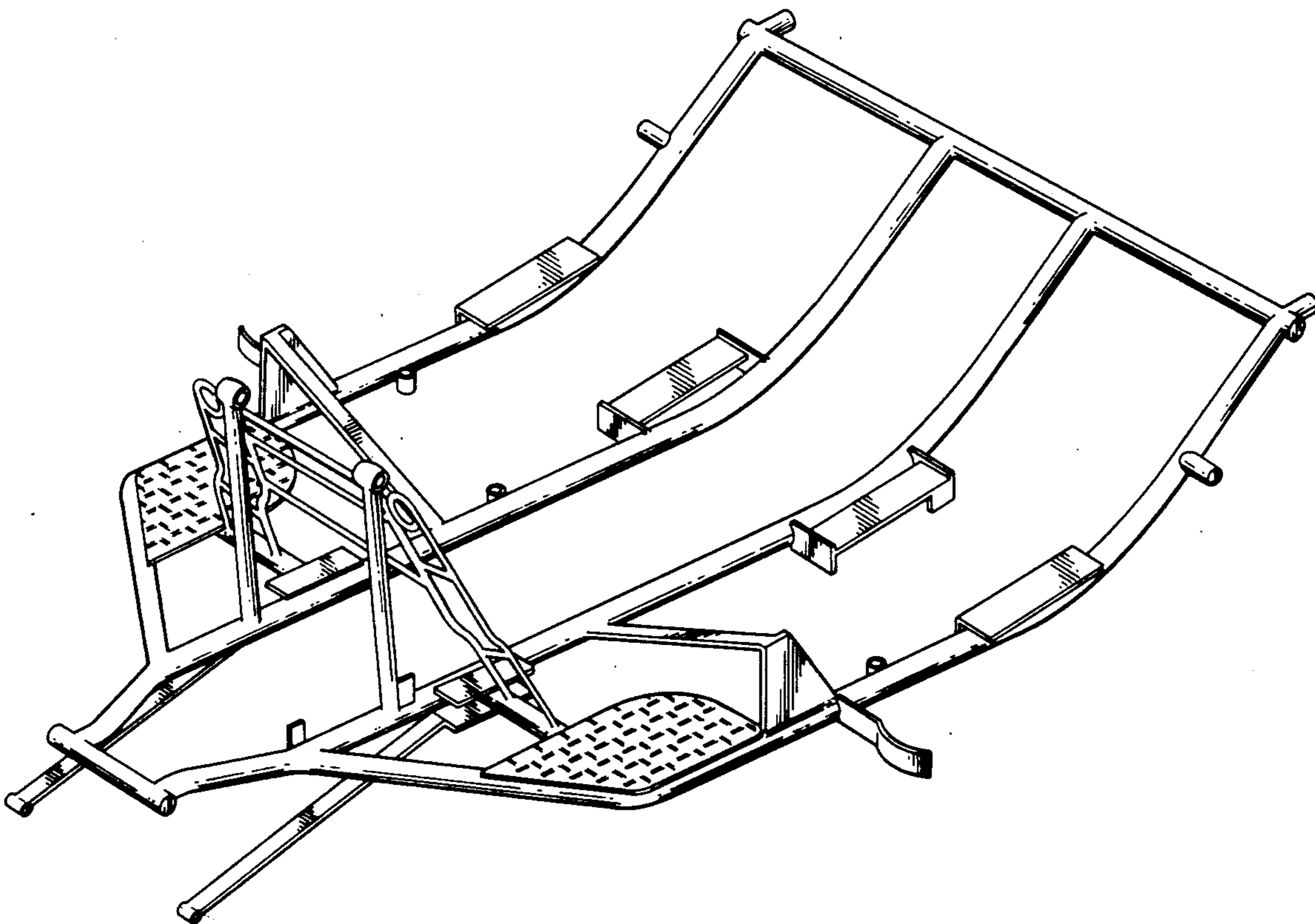

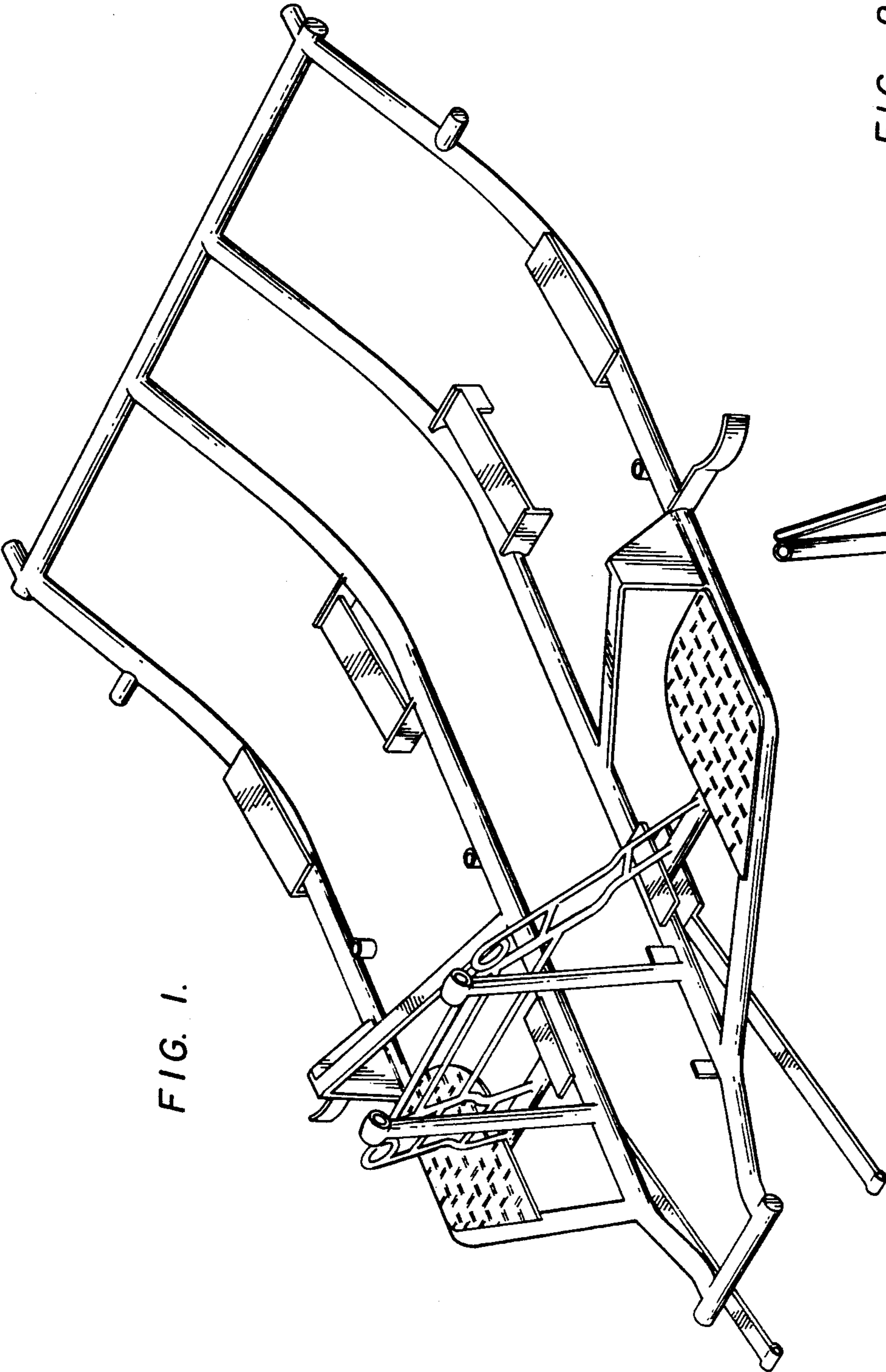

FIG. 1.

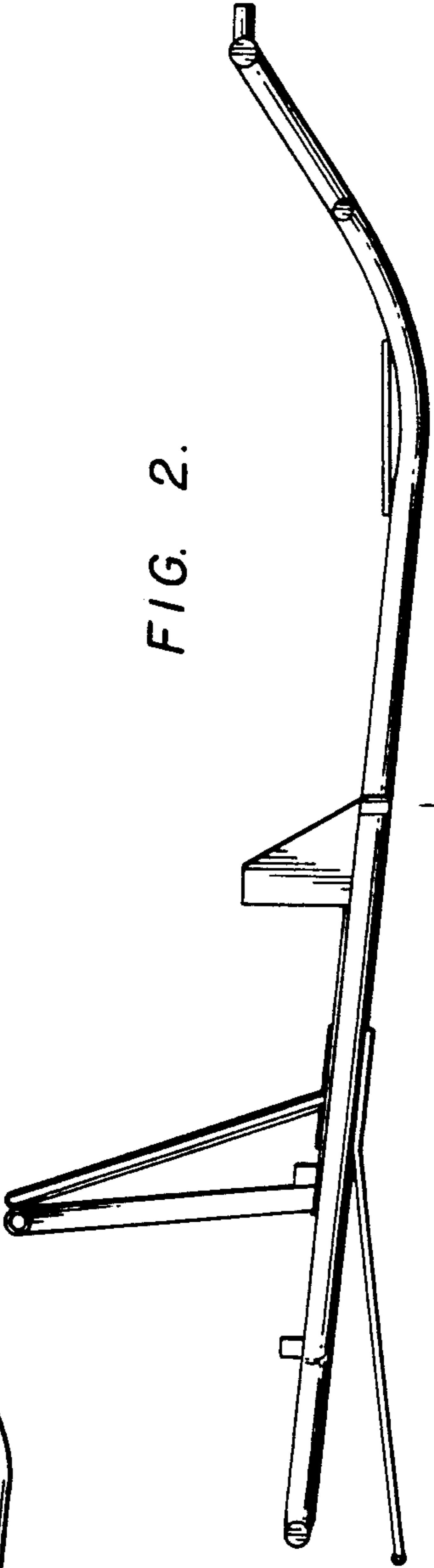

FIG. 2.

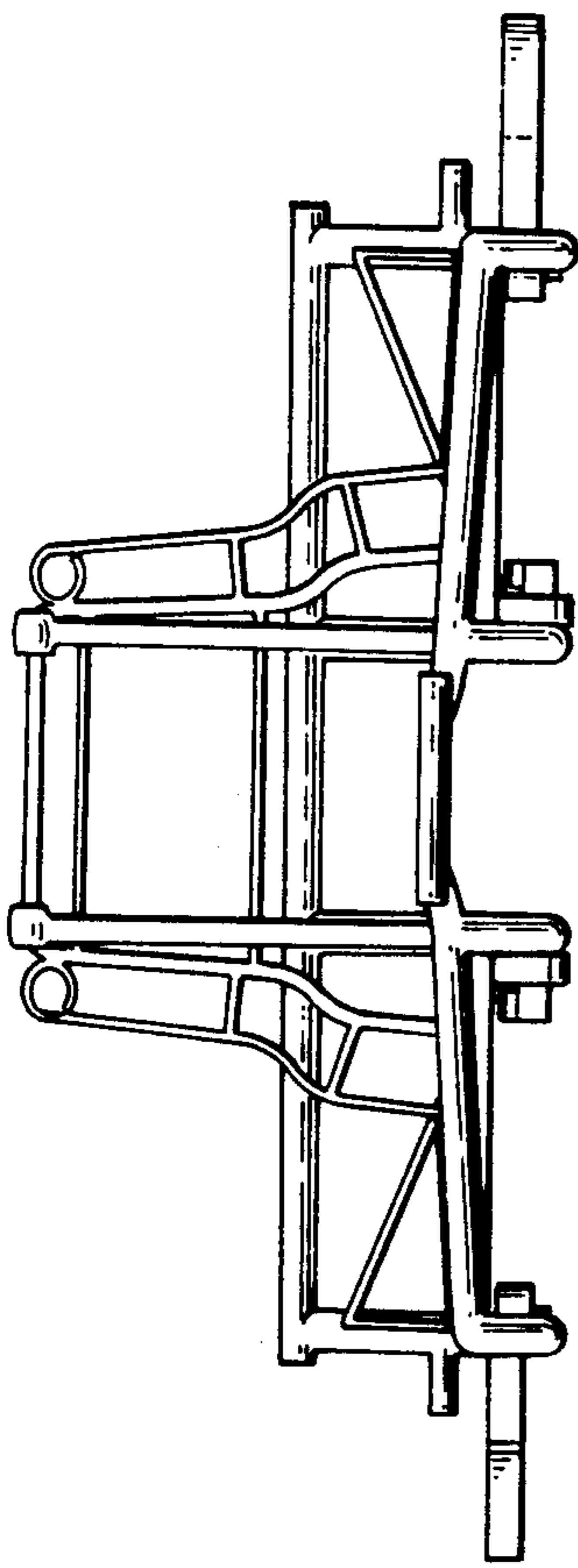

FIG. 4.

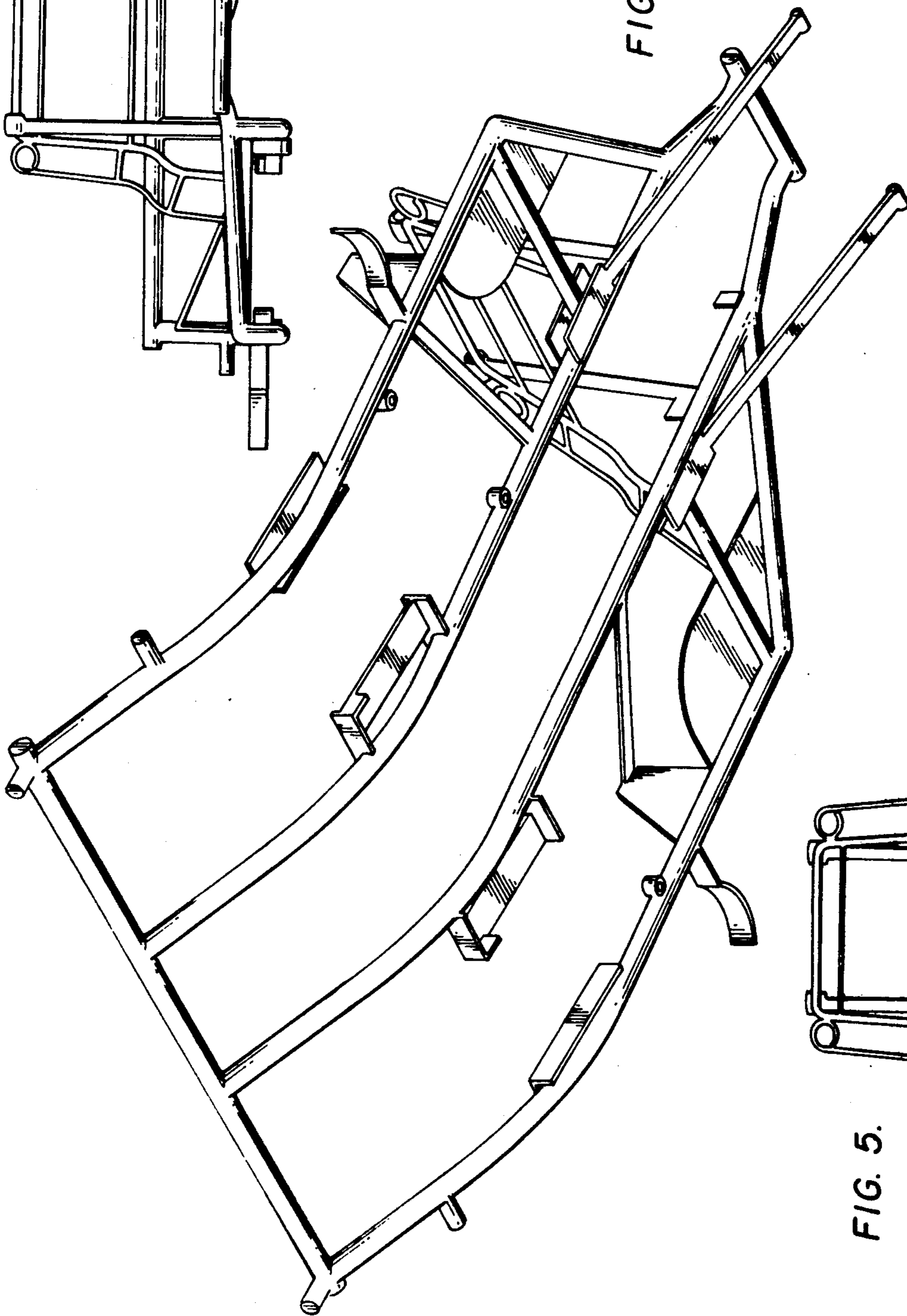

FIG. 3.

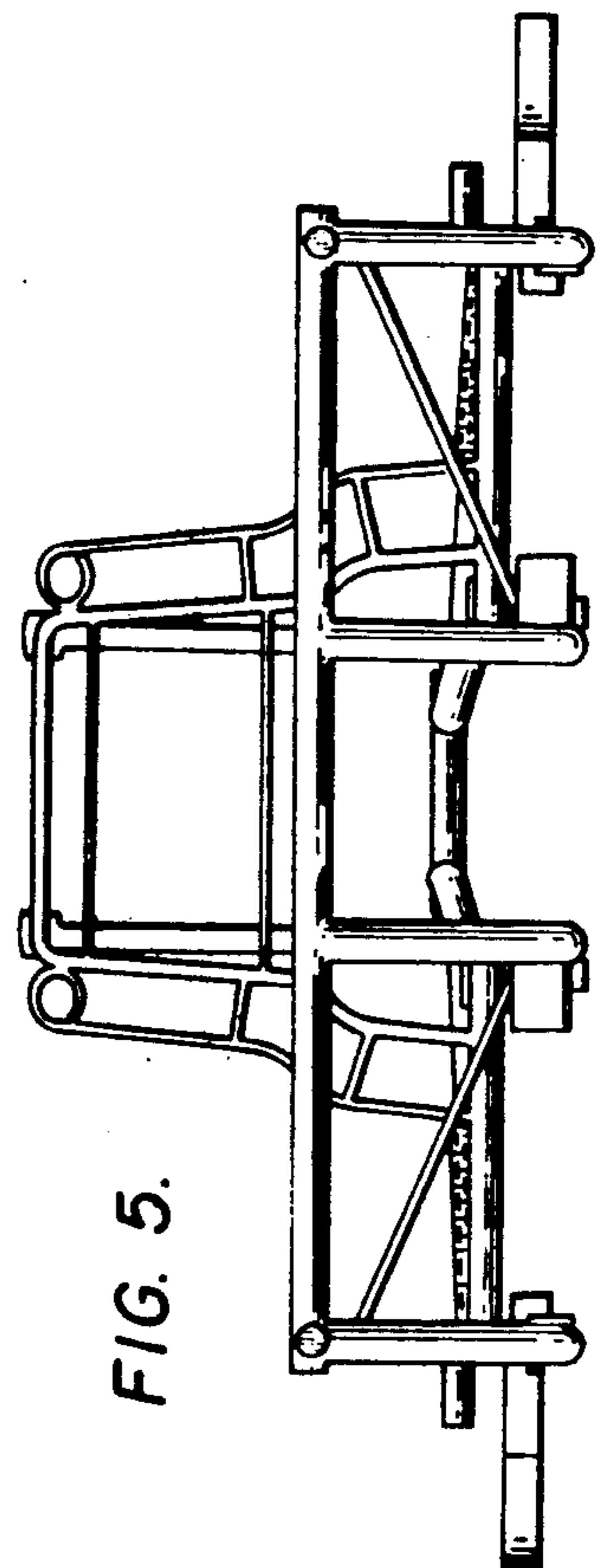

FIG. 5.