

[54] TOY VEHICLE

[76] Inventor: Mel Appel, 9 Nottingham Rd.,  
Livingston, N.J. 07039

[\*\*] Term: 14 Years

[21] Appl. No.: 808,243

[22] Filed: Jun. 20, 1977

[51] Int. Cl. .... D21-01

[52] U.S. Cl. .... D34/15 AJ

[58] Field of Search ..... D34/15 AJ, 15 AN;  
D15/23, 24, 26; 46/97, 201, 202, 206, 210, 214,  
218

[56] References Cited

U.S. PATENT DOCUMENTS

D. 192,088 1/1962 Alvaney ..... D34/15 AJ  
D. 230,289 2/1974 Ouellet ..... D34/15 AJ

D. 238,195 12/1975 Morrison ..... D34/15 AJ  
2,385,965 10/1945 Biby ..... D34/15 AJ

Primary Examiner—Joel Stearman  
Assistant Examiner—C. A. Rademaker  
Attorney, Agent, or Firm—Burton L. Lilling

[57] CLAIM

The ornamental design for a toy vehicle, substantially as shown and described.

DESCRIPTION

FIG. 1 is a right side elevational view of a toy vehicle showing my new design, the side opposite being substantially a mirror image;  
FIG. 2 is a top plan view thereof;  
FIG. 3 is a bottom plan view thereof;  
FIG. 4 is a front elevational view thereof;  
FIG. 5 is a rear elevational view thereof; and  
FIG. 6 is a perspective view showing a front or jaw portion of the vehicle in an open position.

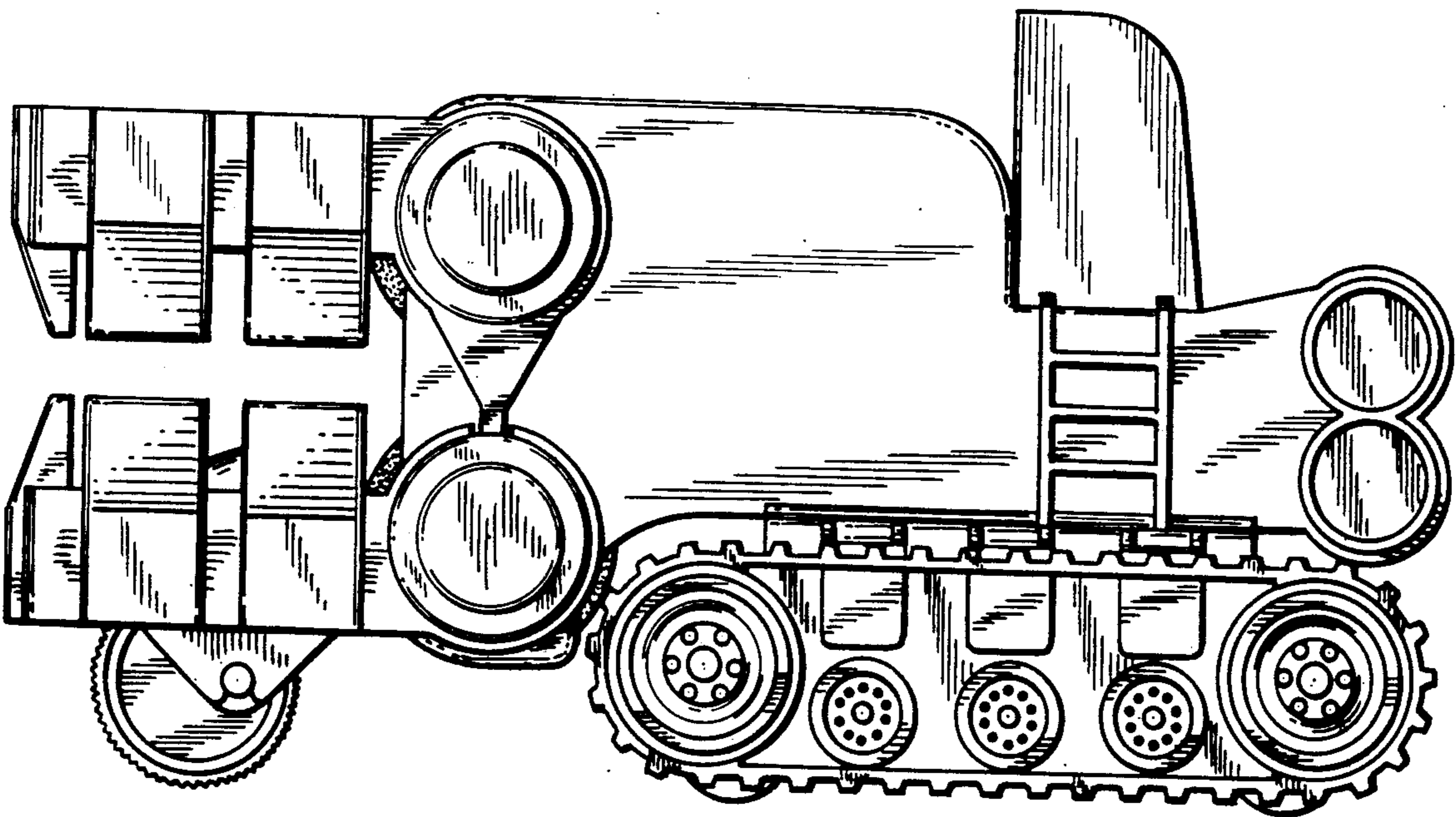

*FIG. 1*

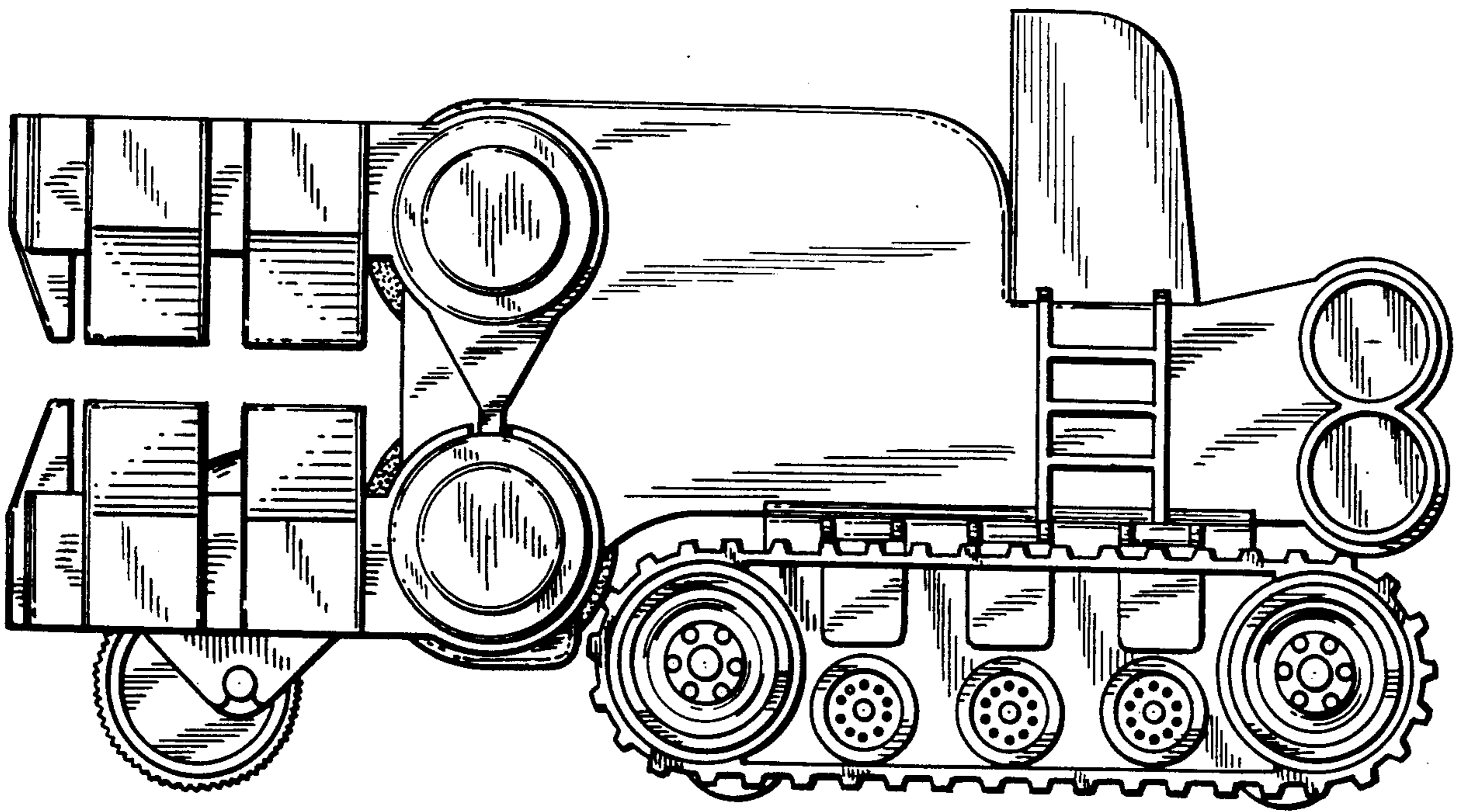

*FIG. 2*

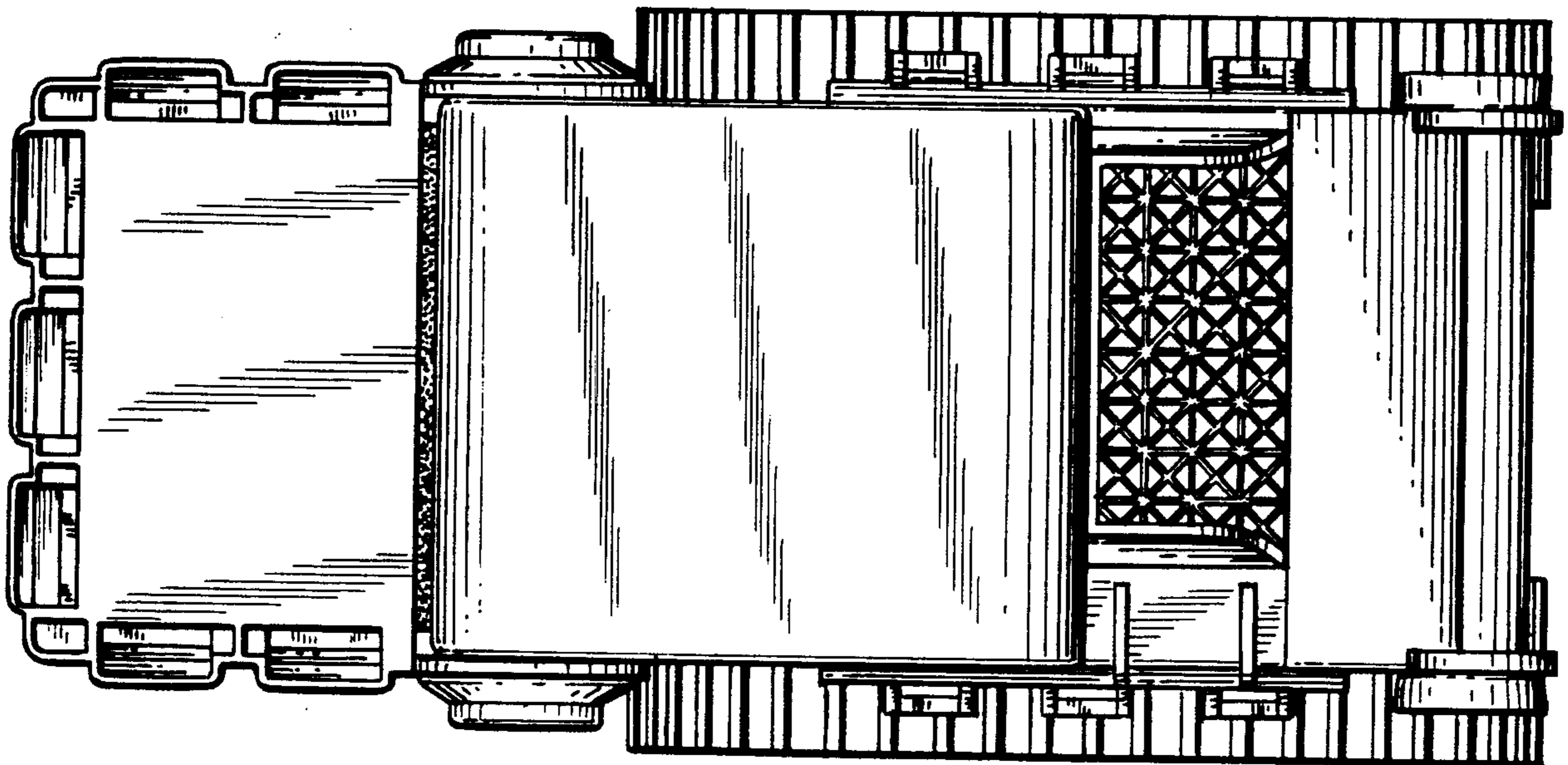

FIG. 3

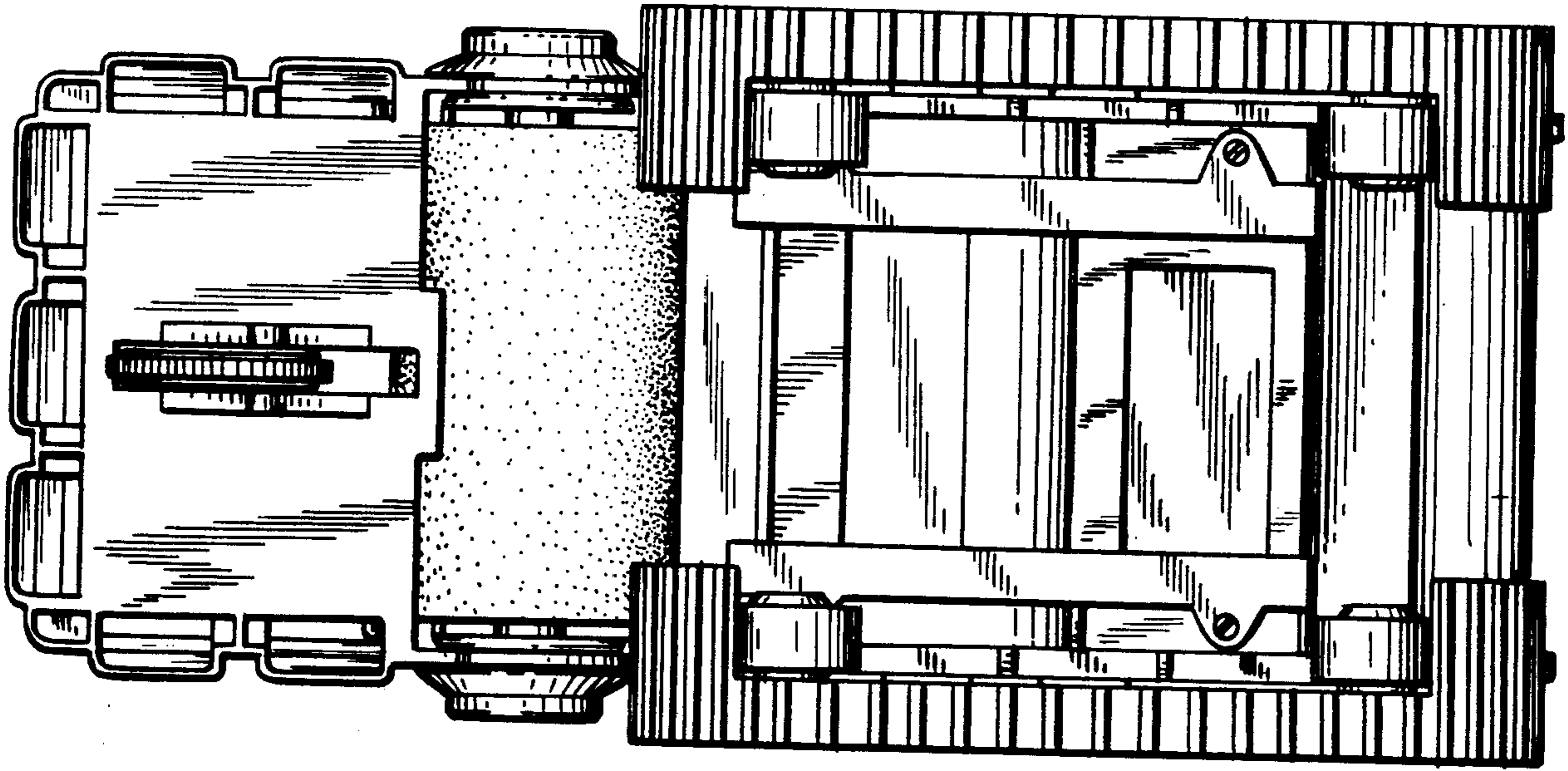
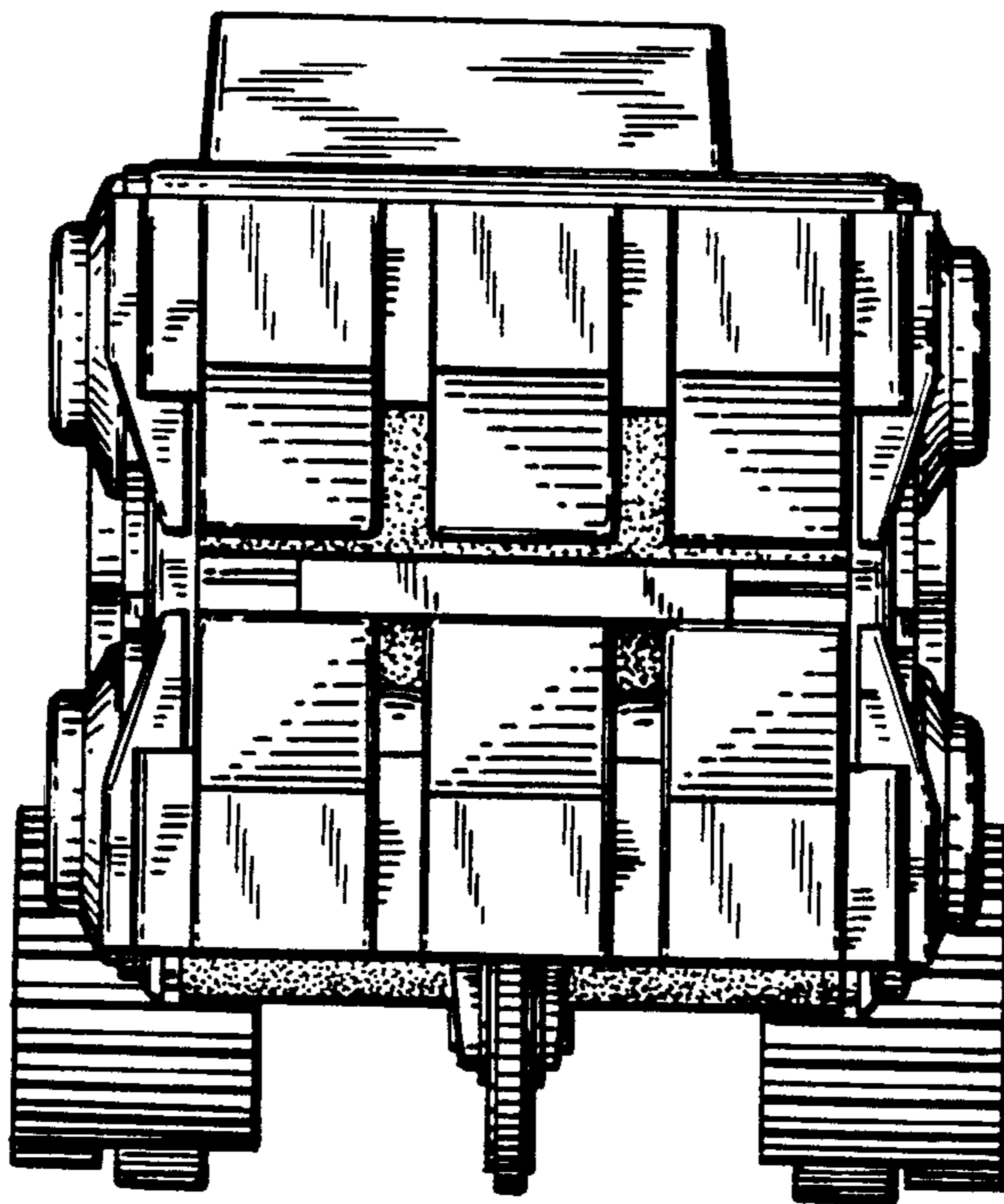
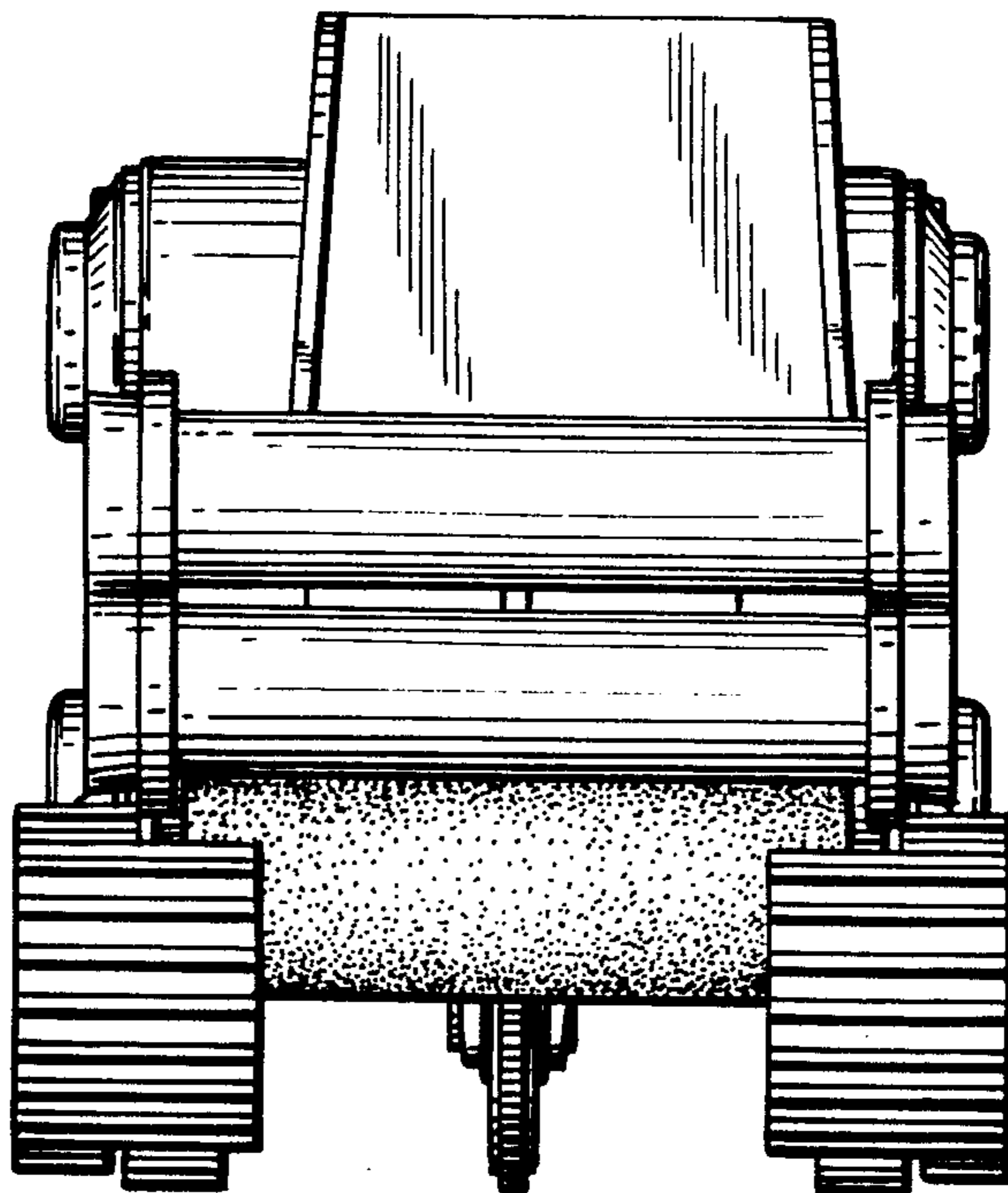

FIG. 4



*FIG. 5*



*FIG. 6*

