

[54] TOY VEHICLE

- [75] Inventors: Gordon A. Barlow, Evanston; Alex Imatt, Chicago, both of Ill.
- [73] Assignee: Marvin Glass & Associates, Chicago, Ill.
- [**] Term: 14 Years
- [21] Appl. No.: 820,357
- [22] Filed: Jul. 29, 1977

- [51] Int. Cl. D21-01
- [52] U.S. Cl. D34/15 MM
- [58] Field of Search D34/15 AJ, 15 MM; 46/113, 216, 217, 218; D12/39, 40, 41

[56] **References Cited**
U.S. PATENT DOCUMENTS

D. 189,741 2/1961 Gatov D34/15 AJ

OTHER PUBLICATIONS

Street Railway Journal, 9-1891, Fig. 2, Adjustable Car.
 Street Railway Journal, 9-1891, p. 509, McDougall Storage Battery Car with Trailer.
 Small World Toys, p. 23, item 971, Street Car.

Primary Examiner—Joel Stearman
Assistant Examiner—C. A. Rademaker
Attorney, Agent, or Firm—Richard D. Mason

[57] CLAIM

The ornamental design for a toy vehicle, as shown and described.

DESCRIPTION

FIG. 1 is a front perspective view of a toy vehicle showing our new design;
 FIG. 2 is a right side elevational view thereof, the left side elevational view being identical thereto;
 FIG. 3 is a front elevational view thereof, the rear elevational view thereof being identical thereto;
 FIG. 4 is a top plan view thereof; and
 FIG. 5 is a bottom plan view thereof.

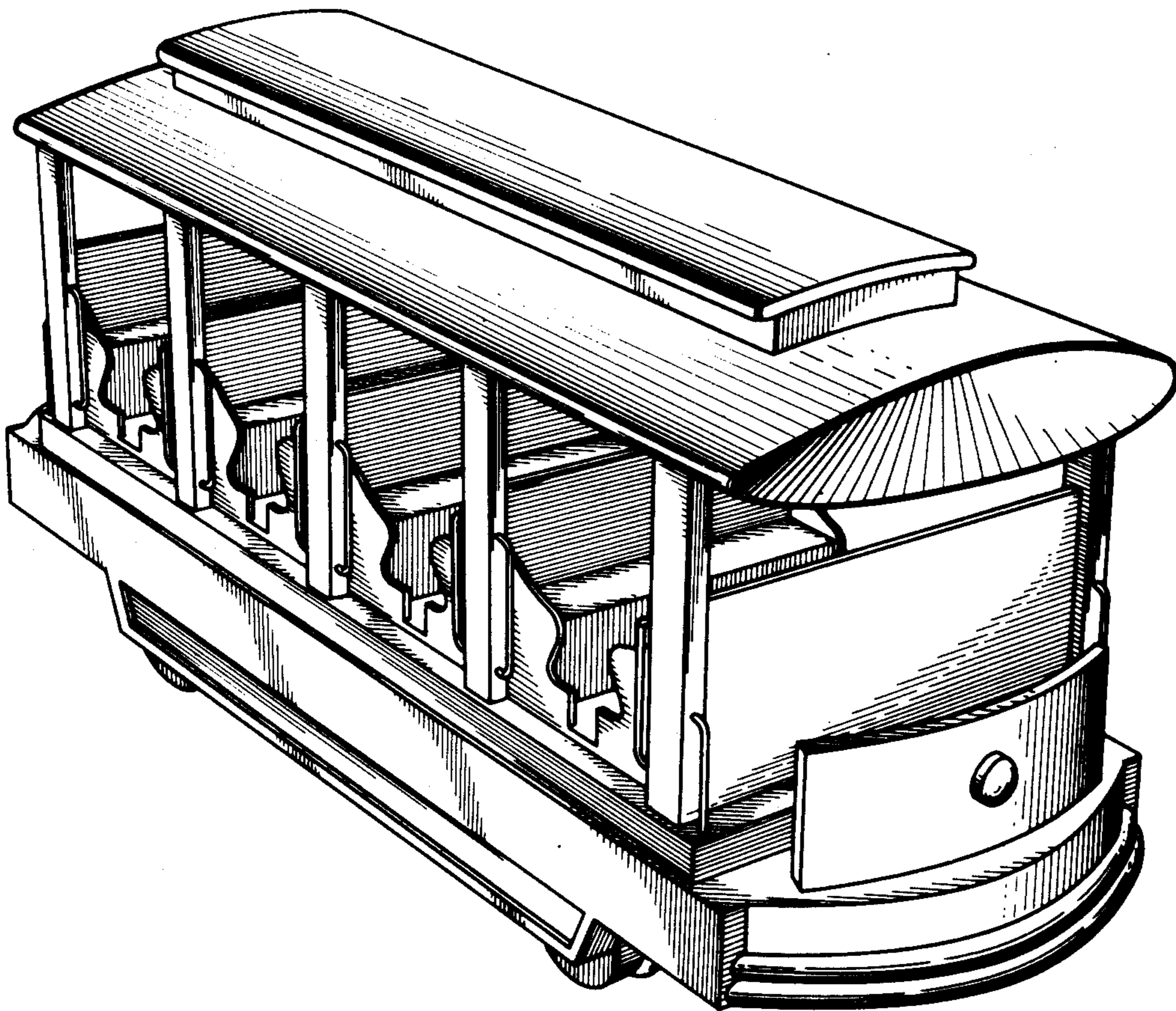

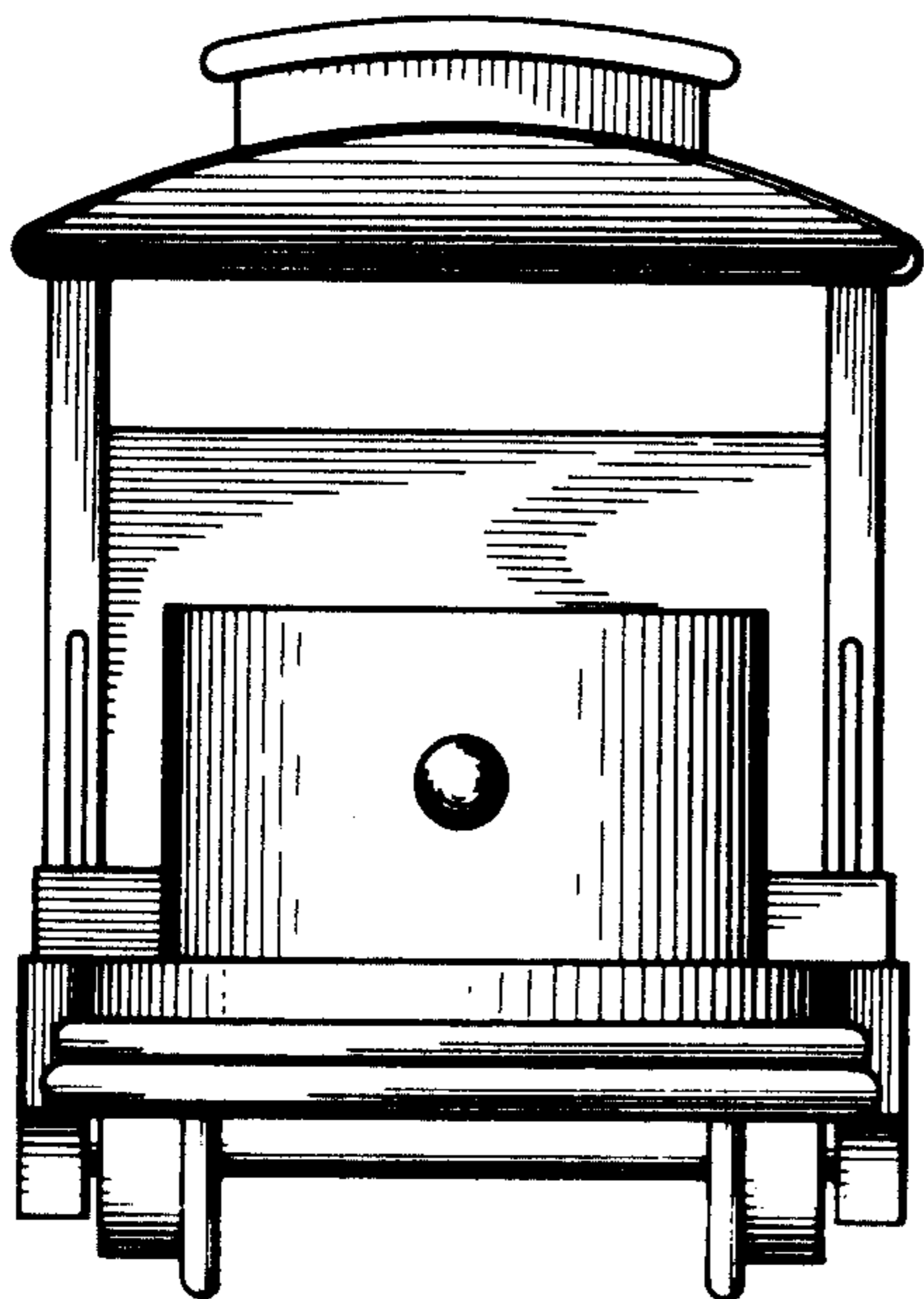
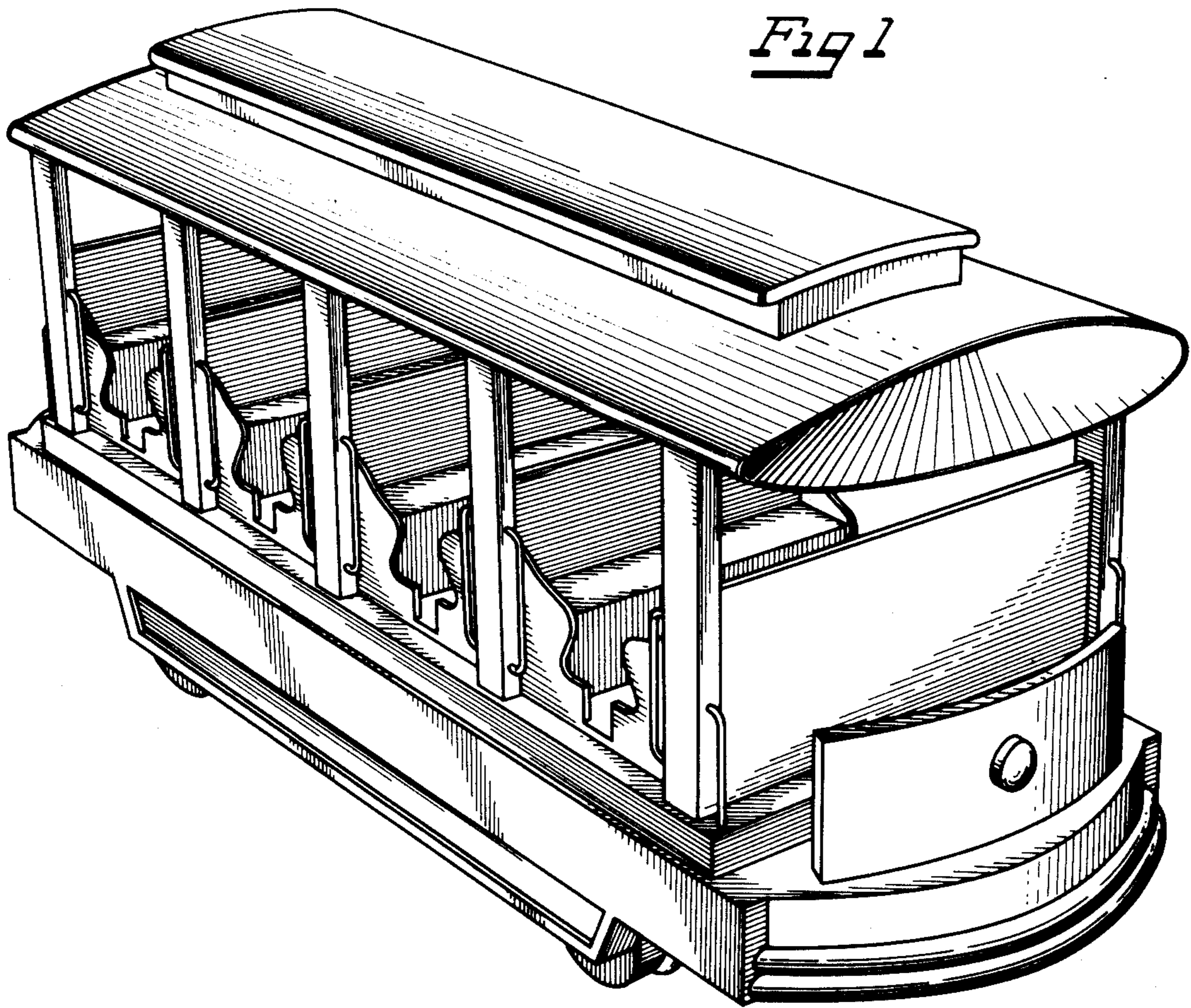

Fig 3

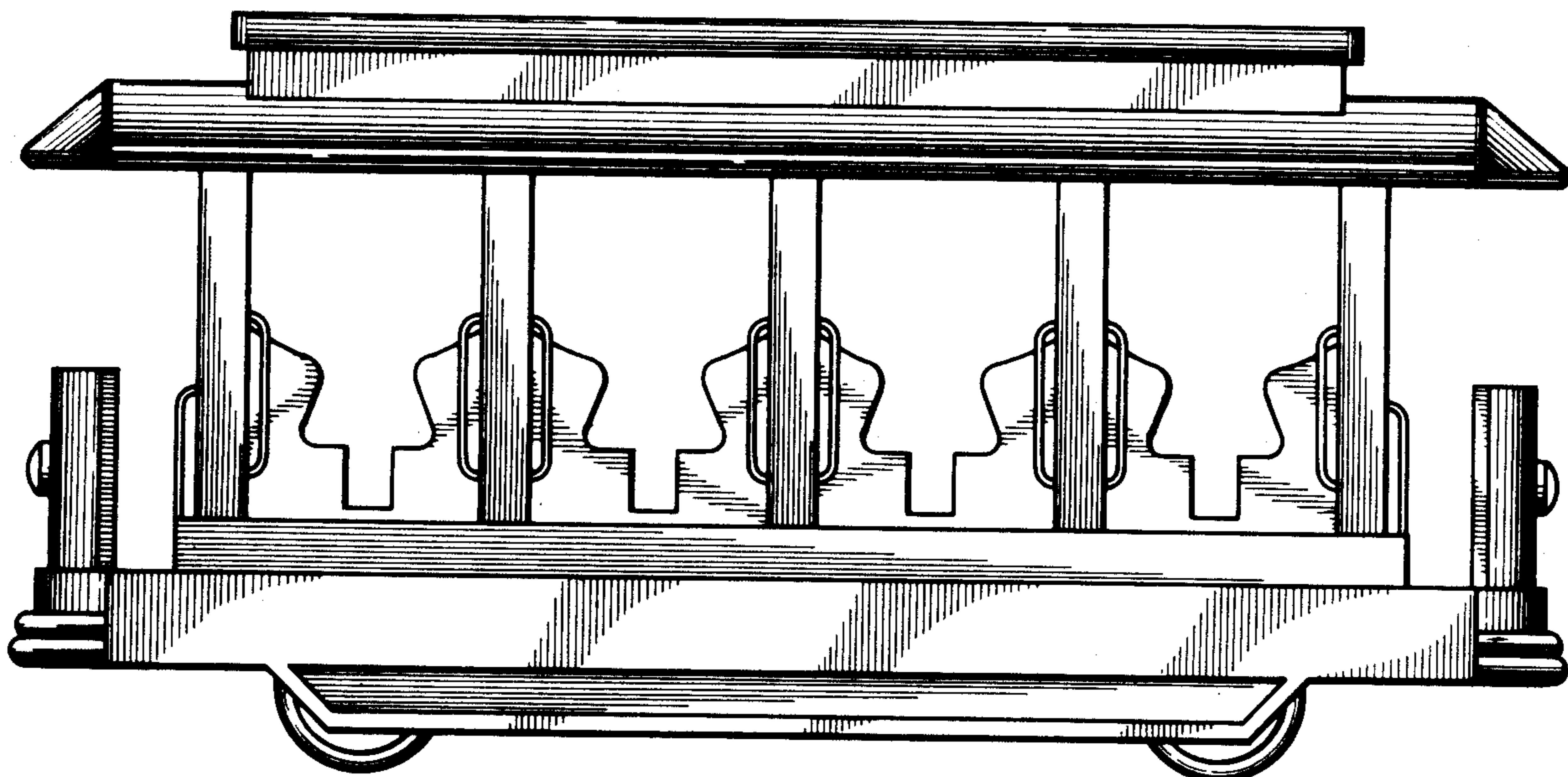

Fig 4

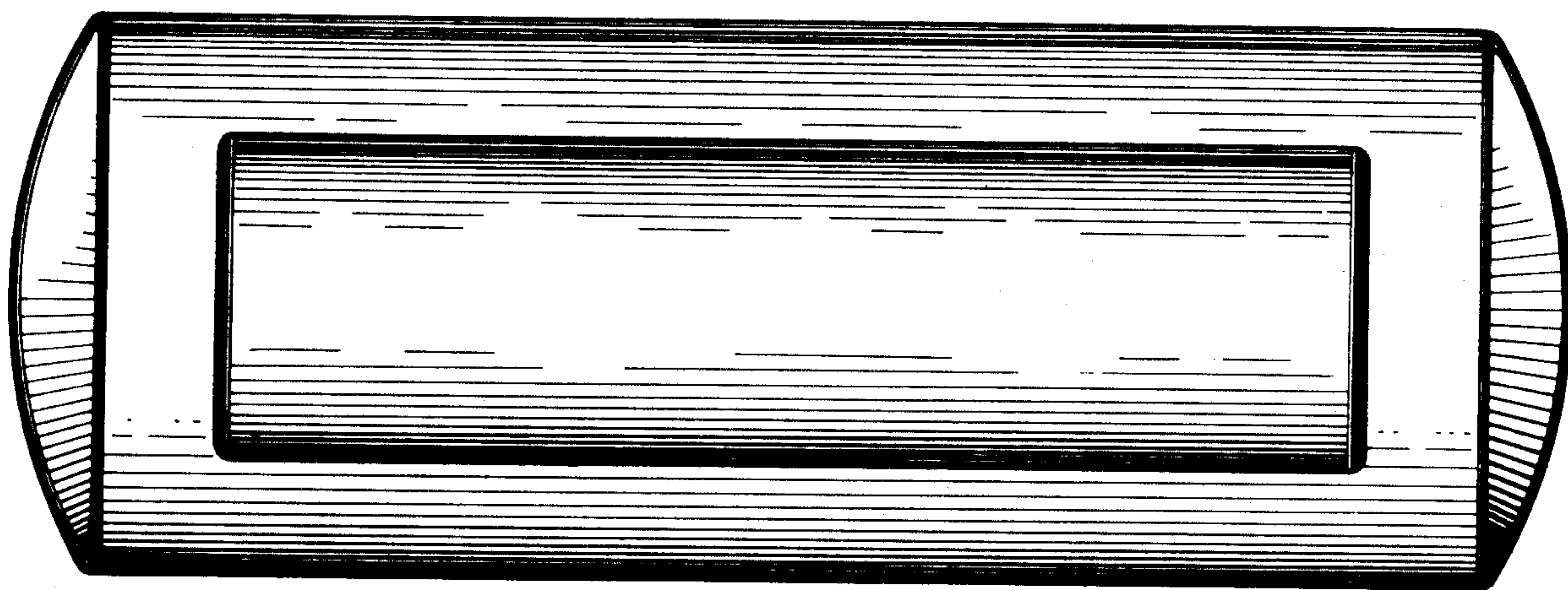

Fig 5

