

[54] ILLUMINATED OVERHEAD ADVERTISING DISPLAY

[76] Inventor: Paul Belokin, Jr., R.R. #4, Hayward, Wis. 54843

[\*\*] Term: 14 Years

[21] Appl. No.: 817,127

[22] Filed: Jul. 20, 1977

[51] Int. Cl. .... D20-03

[52] U.S. Cl. .... D96/12 R

[58] Field of Search ..... D96/12 R; 40/125 R, 40/125 H, 128, 541, 564, 560, 572, 573, 574, 577

[56] References Cited

U.S. PATENT DOCUMENTS

978,218	12/1910	Sargent	40/128 X
3,633,299	1/1972	Westin	40/129 C
3,984,931	10/1976	Belokin, Jr.	40/128 X

FOREIGN PATENT DOCUMENTS

1008393 5/1952 France ..... 40/125 R

Primary Examiner—Wallace R. Burke  
Assistant Examiner—Catherine Kemper  
Attorney, Agent, or Firm—Watson D. Harbaugh

[57] CLAIM

The ornamental design for an illuminated overhead advertising display, substantially as shown and described.

DESCRIPTION

FIG. 1 is a bottom perspective view of an illuminated overhead advertising display, showing my new design; FIG. 2 is a top perspective view thereof; FIG. 3 is a side elevational view, the opposite side being a mirror image thereof; FIG. 4 is a top plan view thereof; FIG. 5 is a bottom plan view thereof; FIG. 6 is an end elevational view, the opposite end being a mirror image thereof.

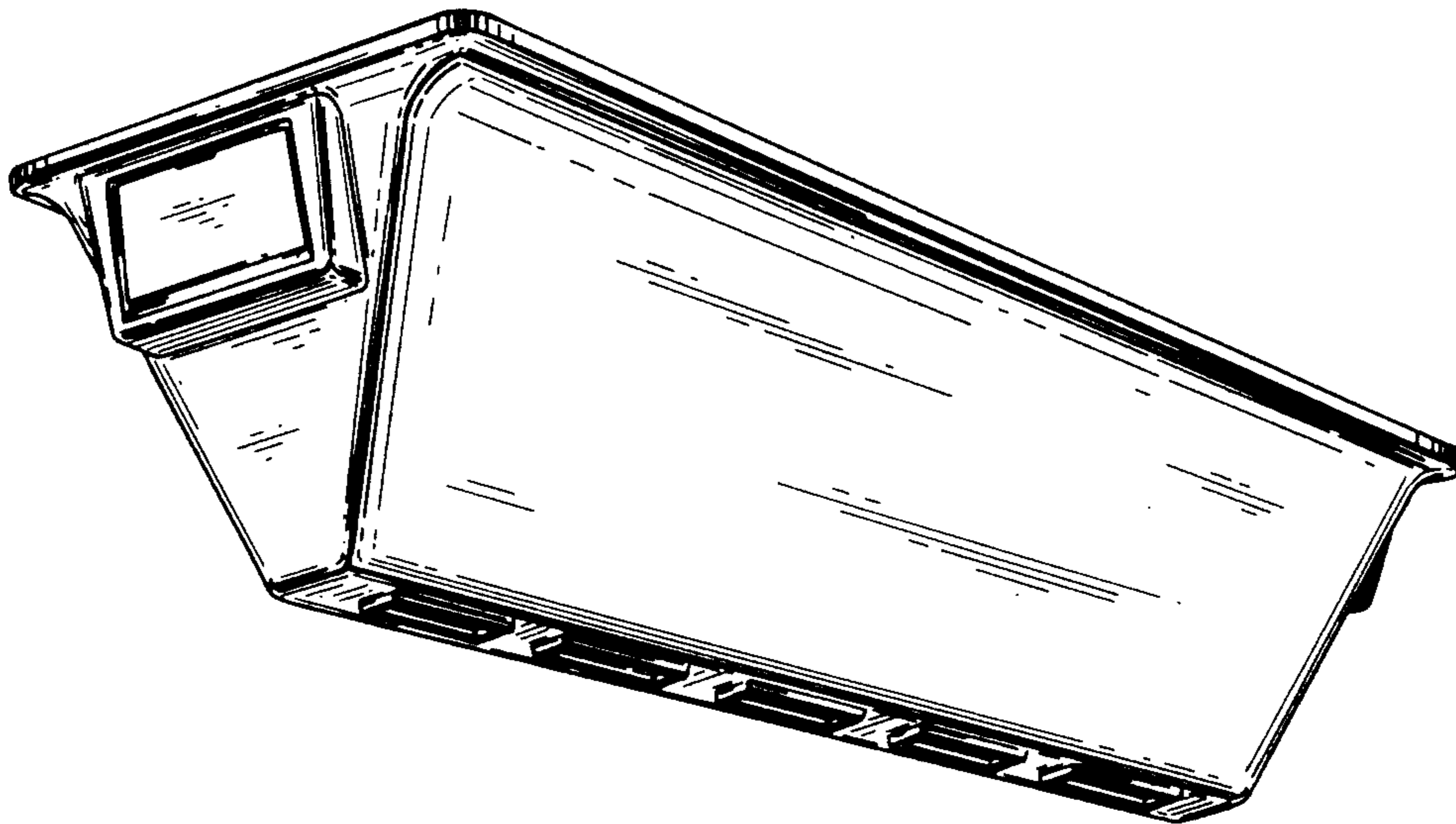

**FIG. 1**

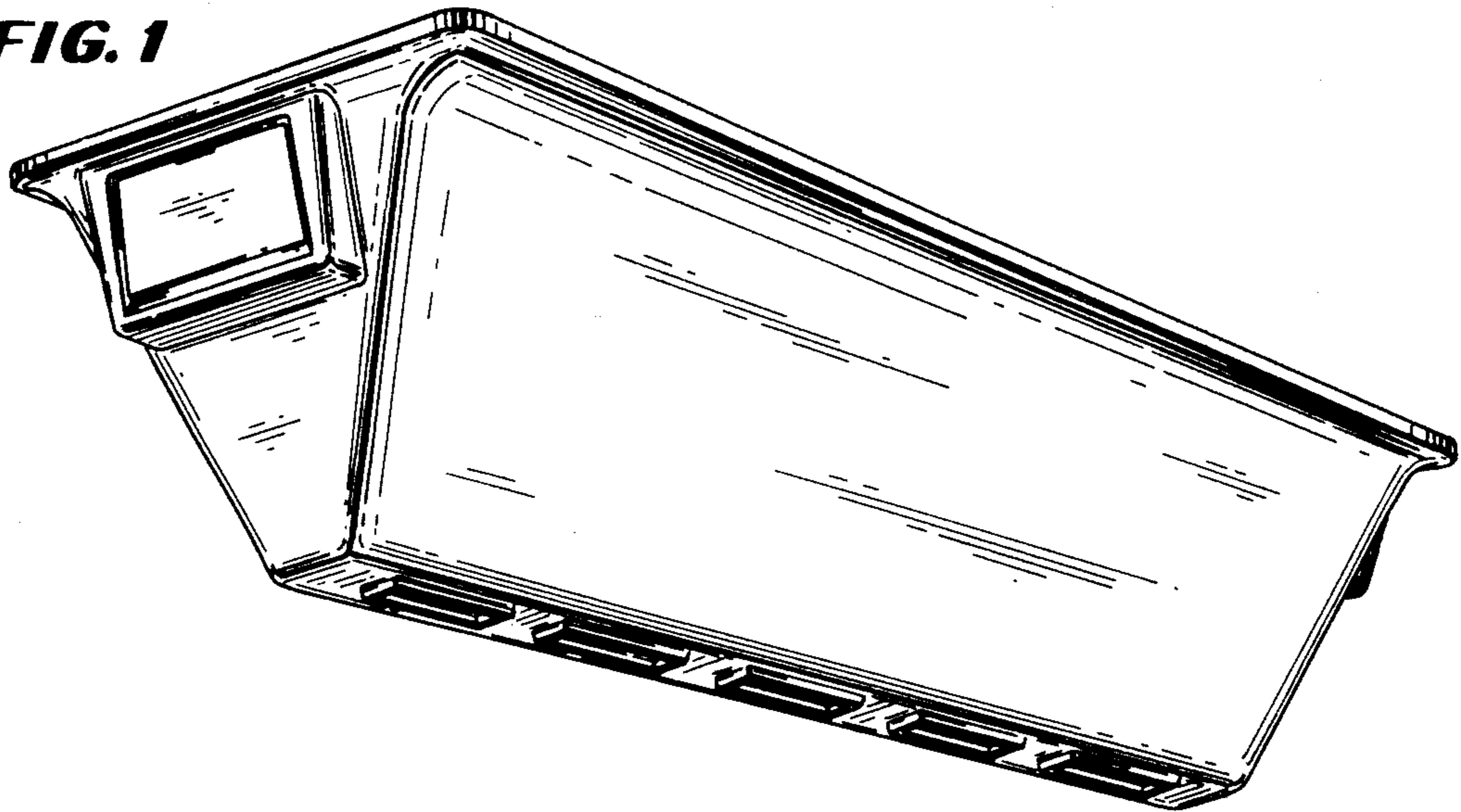

**FIG. 2**

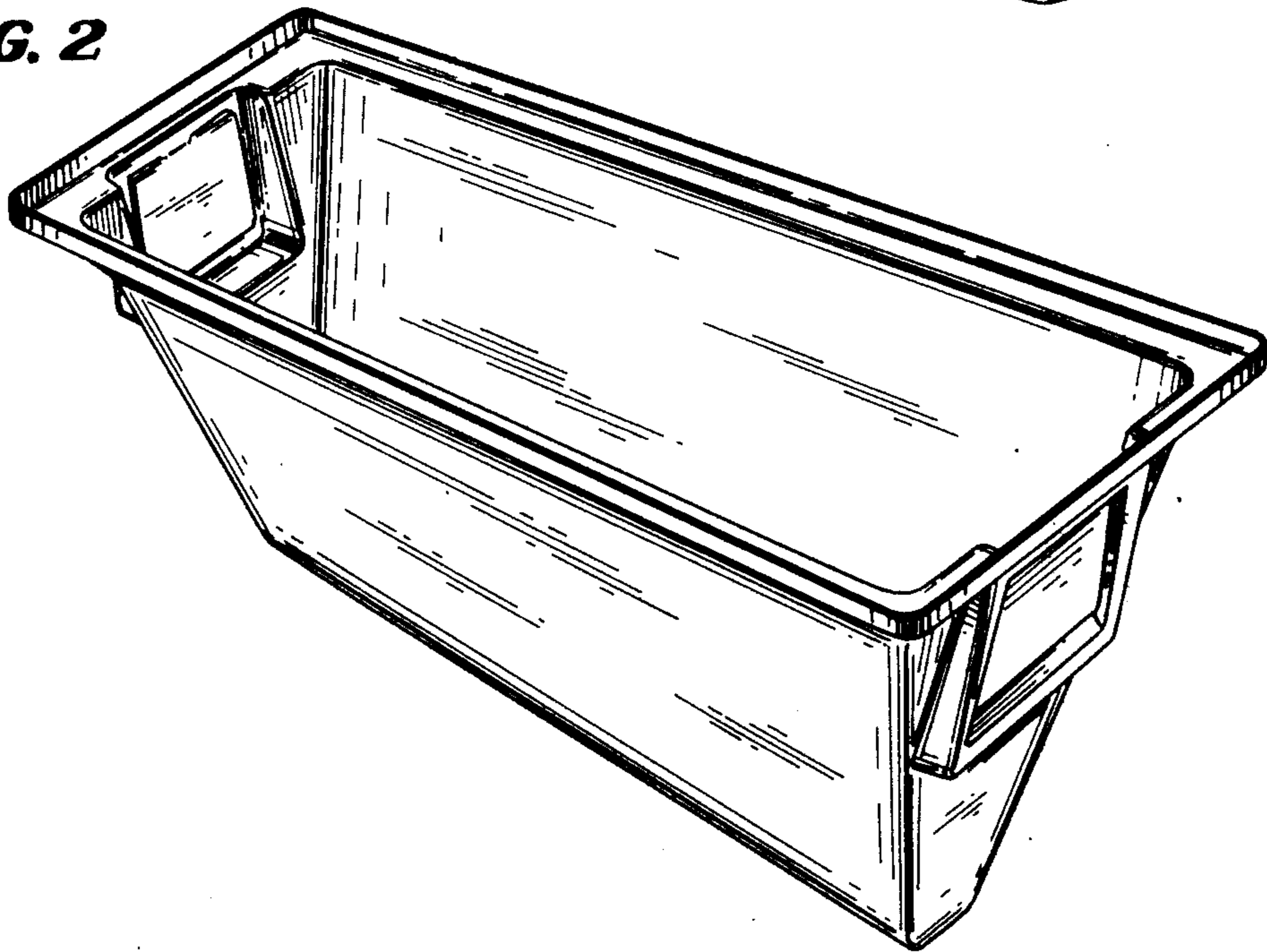

**FIG. 3**

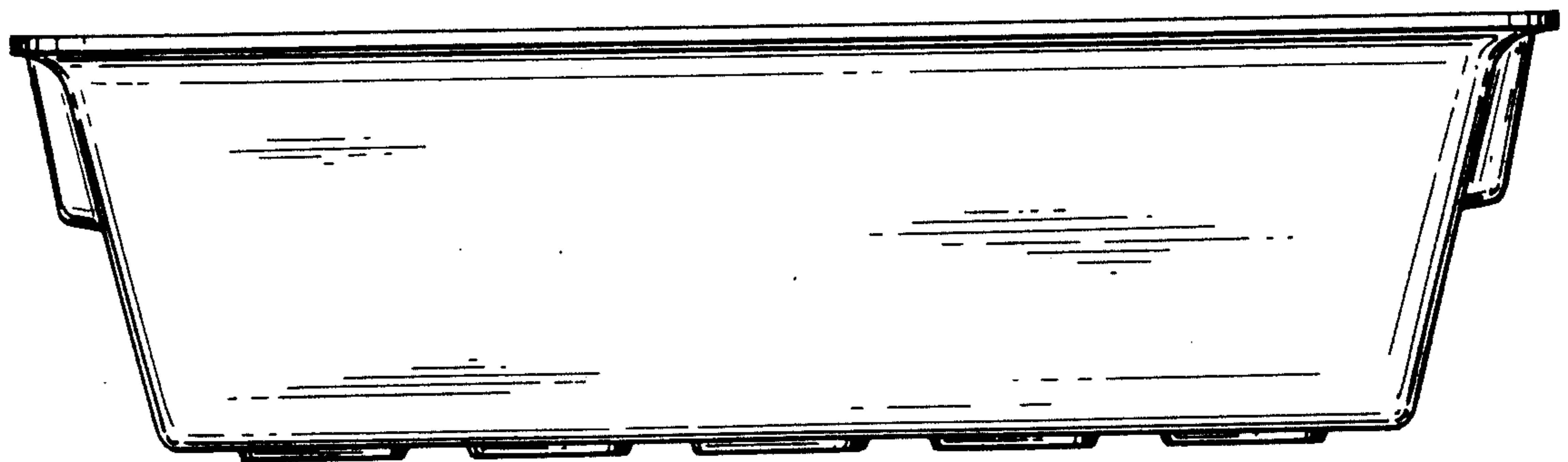

**FIG. 4**

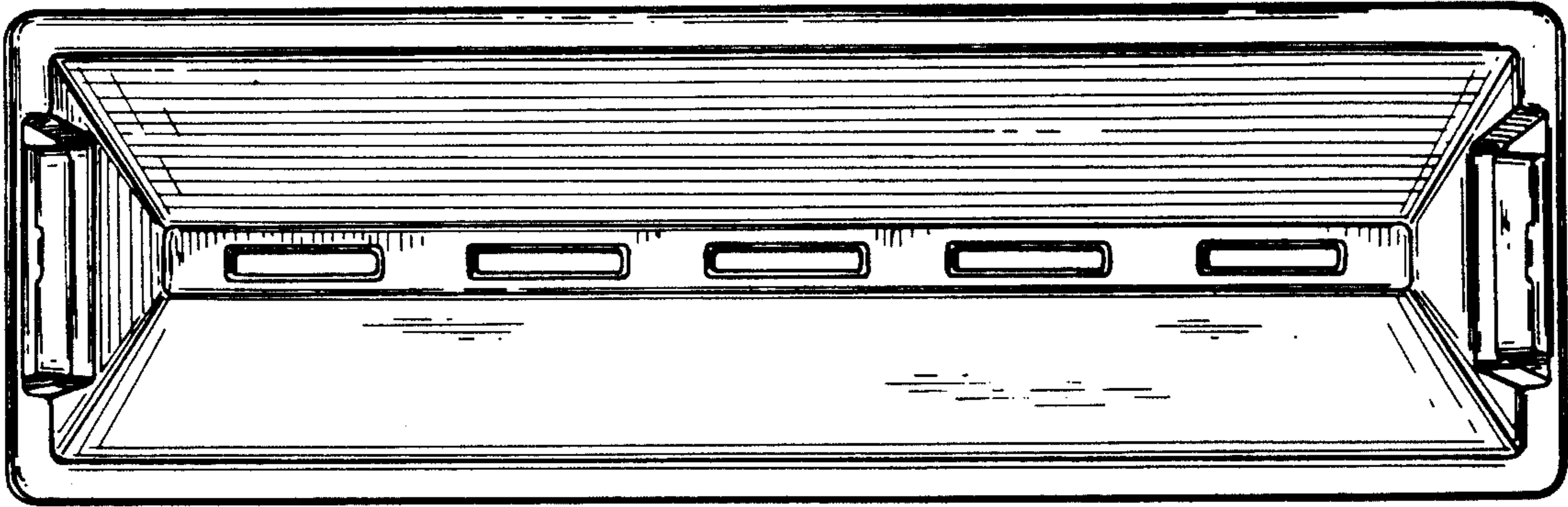

**FIG. 5**

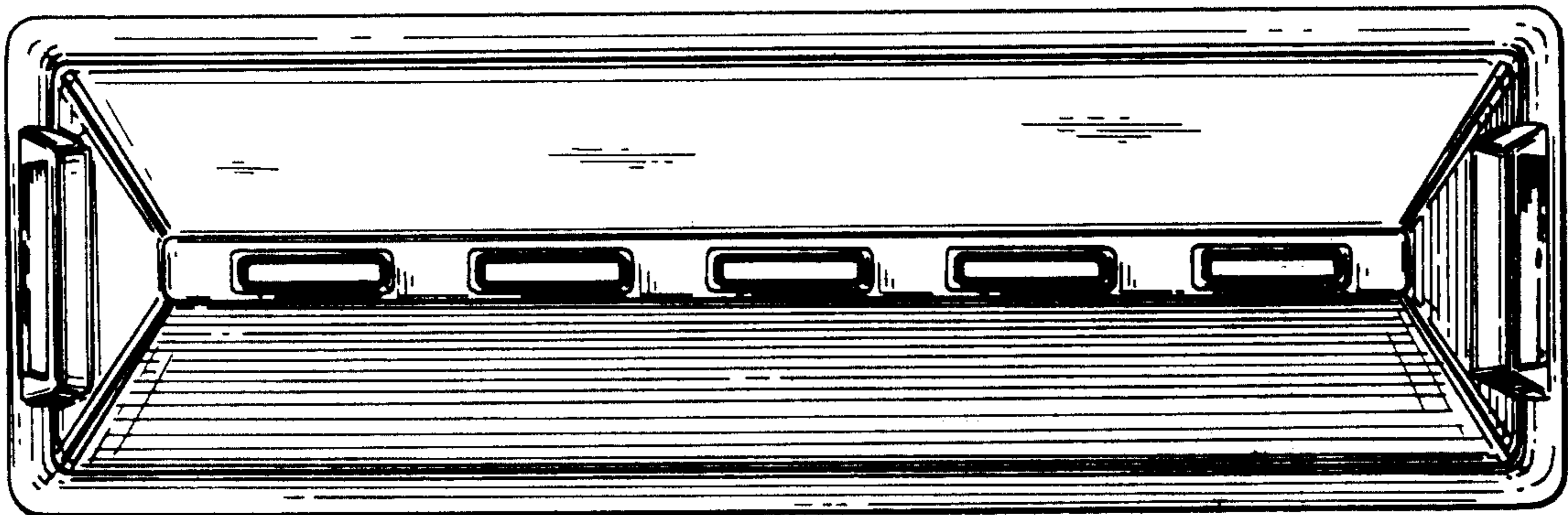

**FIG. 6**

