

[54] AUTOMOTIVE LUGGAGE RACK STANCHION

[76] Inventor: John A. Bott, 931 Lakeshore Dr., Grosse Pointe Shores, Mich. 48236

[**] Term: 14 Years

[21] Appl. No.: 807,028

[22] Filed: Jun. 16, 1977

[51] Int. Cl. D12-16

[52] U.S. Cl. D12/157

[58] Field of Search D12/157; 224/42.1 R, 224/42.1 D, 42.1 E, 42.1 F, 42.1 G, 42.1 H; 280/179 R

[56] References Cited

U.S. PATENT DOCUMENTS

| | | | | |
|------------|--------|------|-------|---------|
| D. 212,186 | 9/1968 | Bott | | D12/157 |
| D. 215,277 | 9/1969 | Bott | | D12/157 |
| D. 215,278 | 9/1969 | Bott | | D12/157 |

| | | | | |
|------------|---------|------|-------|------------|
| D. 222,617 | 11/1971 | Bott | | D12/157 |
| 3,840,250 | 10/1974 | Bott | | 280/179 R |
| 3,853,254 | 12/1974 | Helm | | 224/42.1 D |
| 3,951,320 | 4/1976 | Bott | | 224/42.1 D |

Primary Examiner—Wallace R. Burke
Assistant Examiner—James M. Gandy
Attorney, Agent, or Firm—J. King Harness

[57] CLAIM

The ornamental design for an automotive luggage rack stanchion, as shown.

DESCRIPTION

FIG. 1 is a perspective view of an automotive luggage rack stanchion showing my new design; FIG. 2 is a side elevational view thereof; FIG. 3 is a left end elevational view thereof; FIG. 4 is a right end elevational view thereof; FIG. 5 is a top plan view thereof; and FIG. 6 is a side elevational view thereof opposite to that shown in FIG. 2.

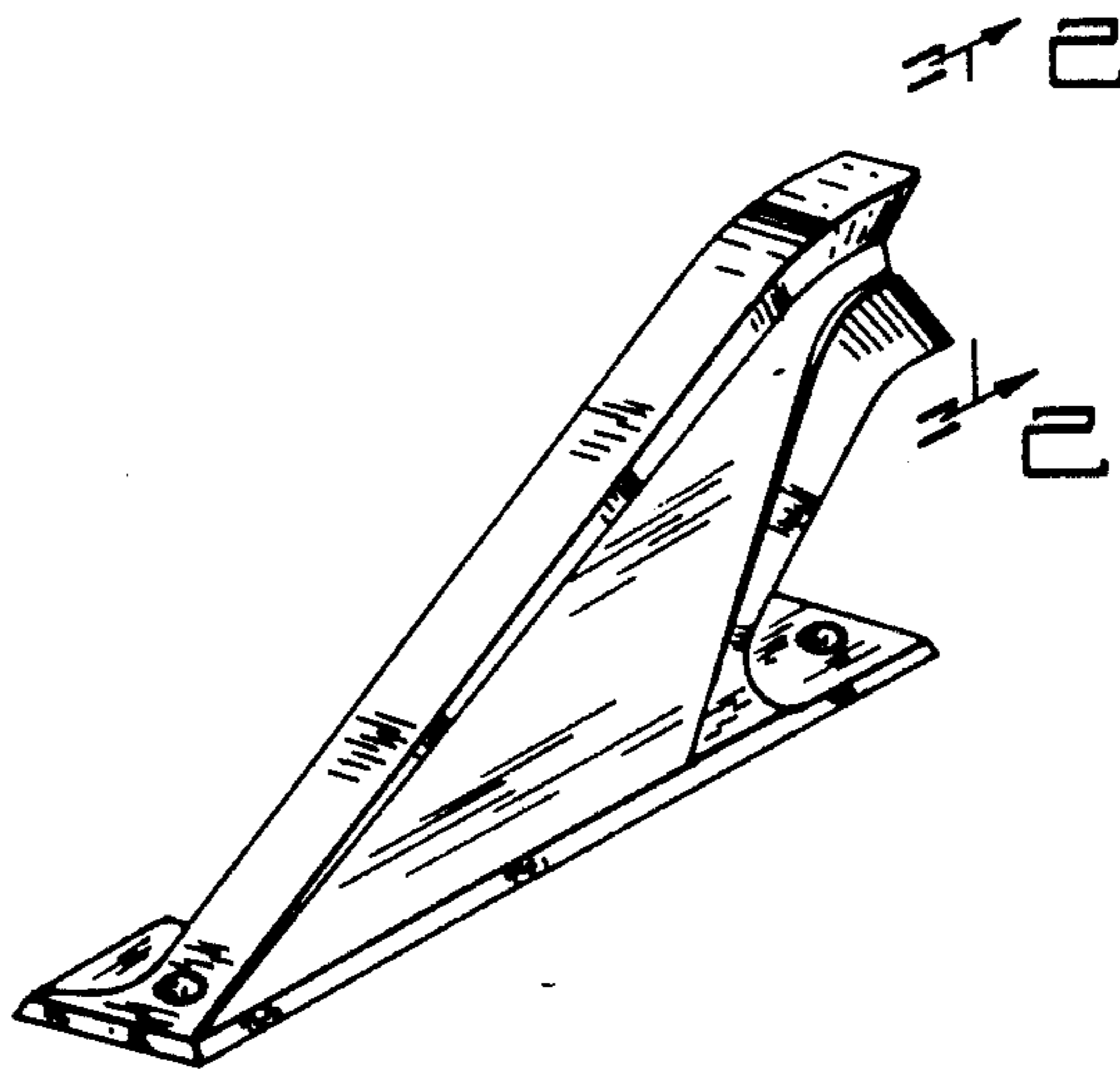

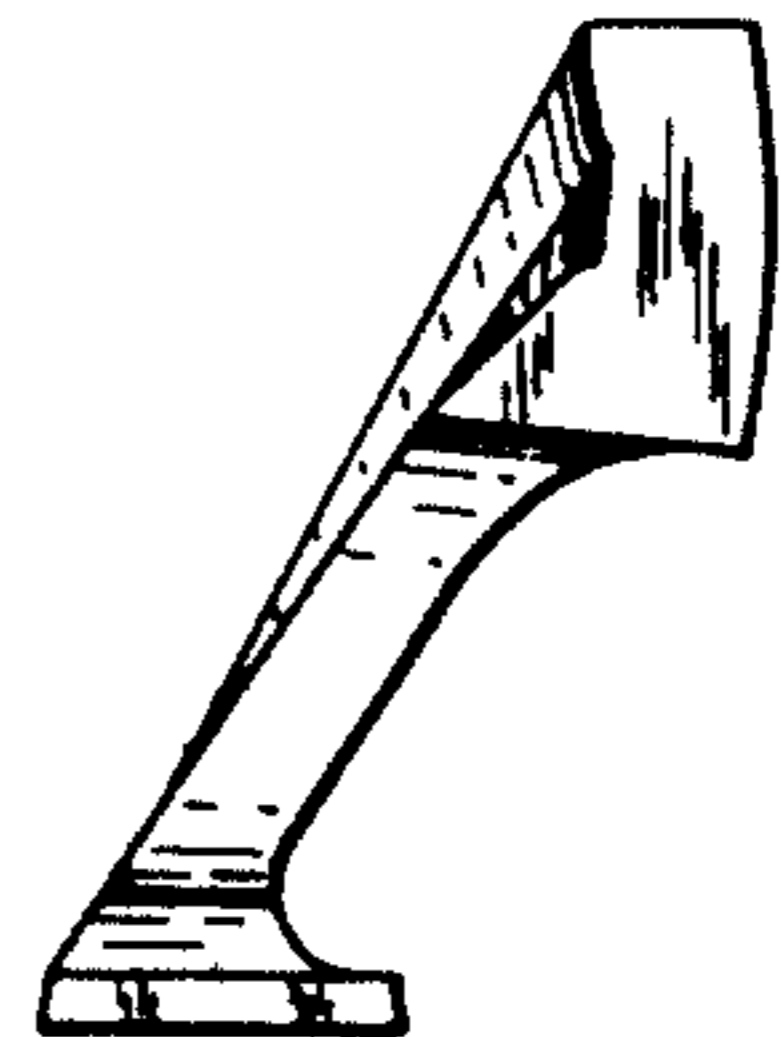
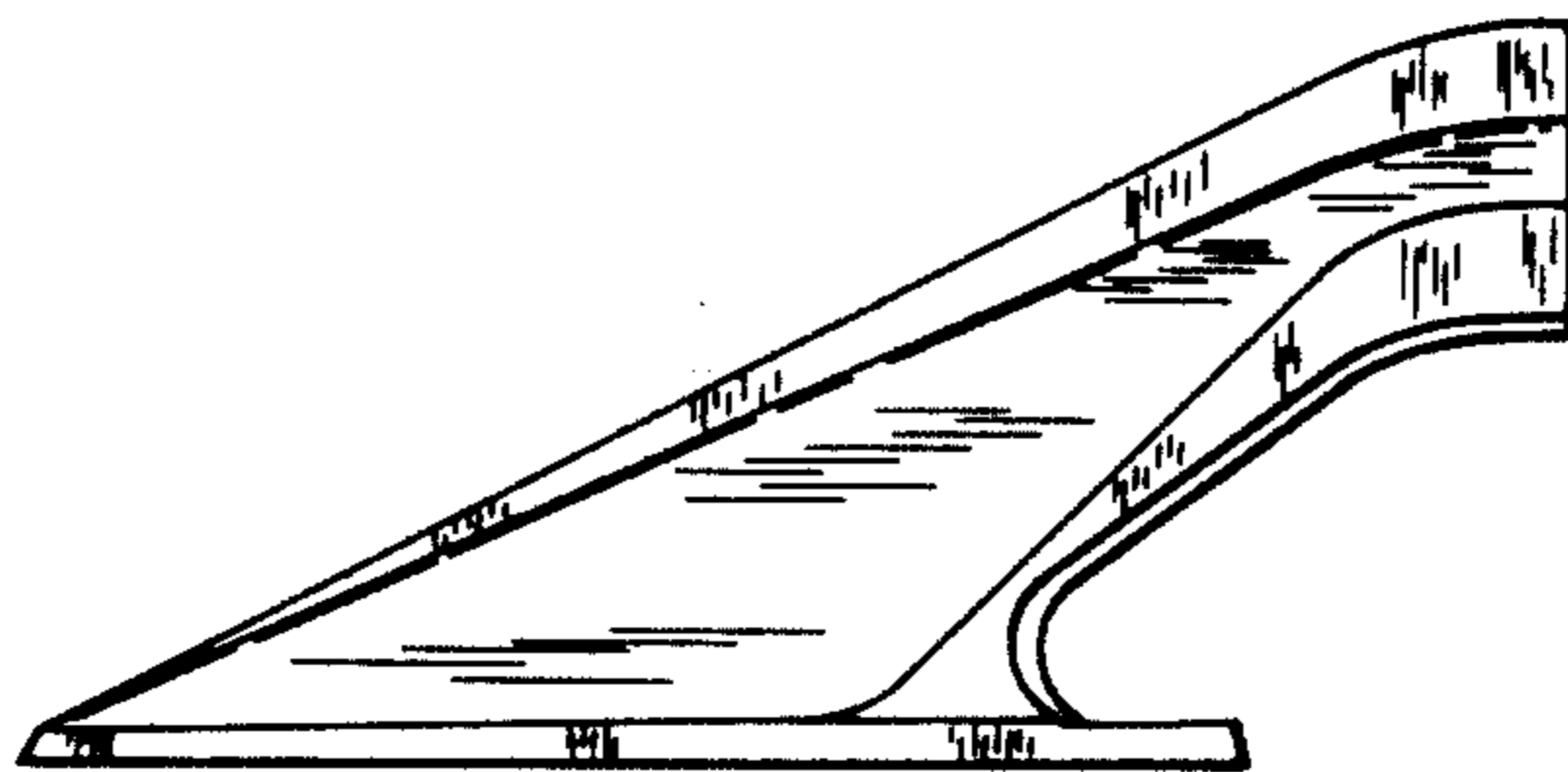
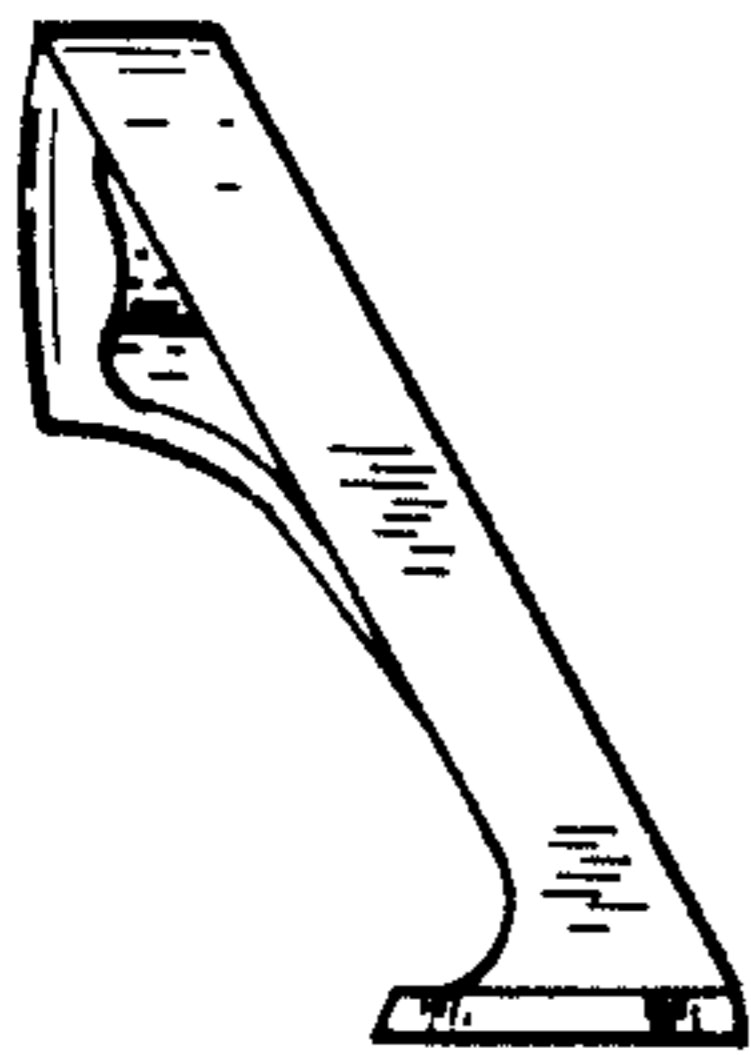
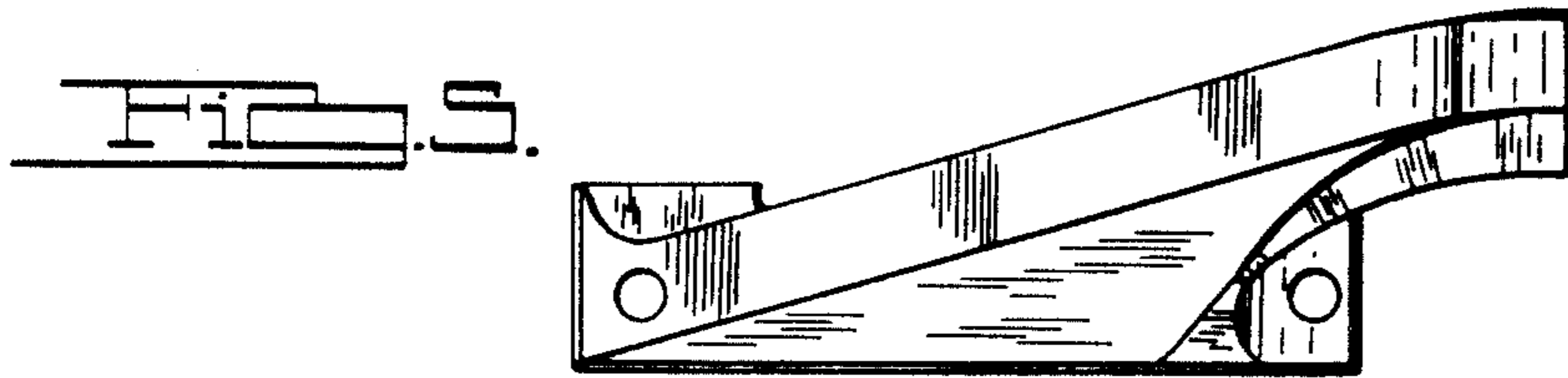
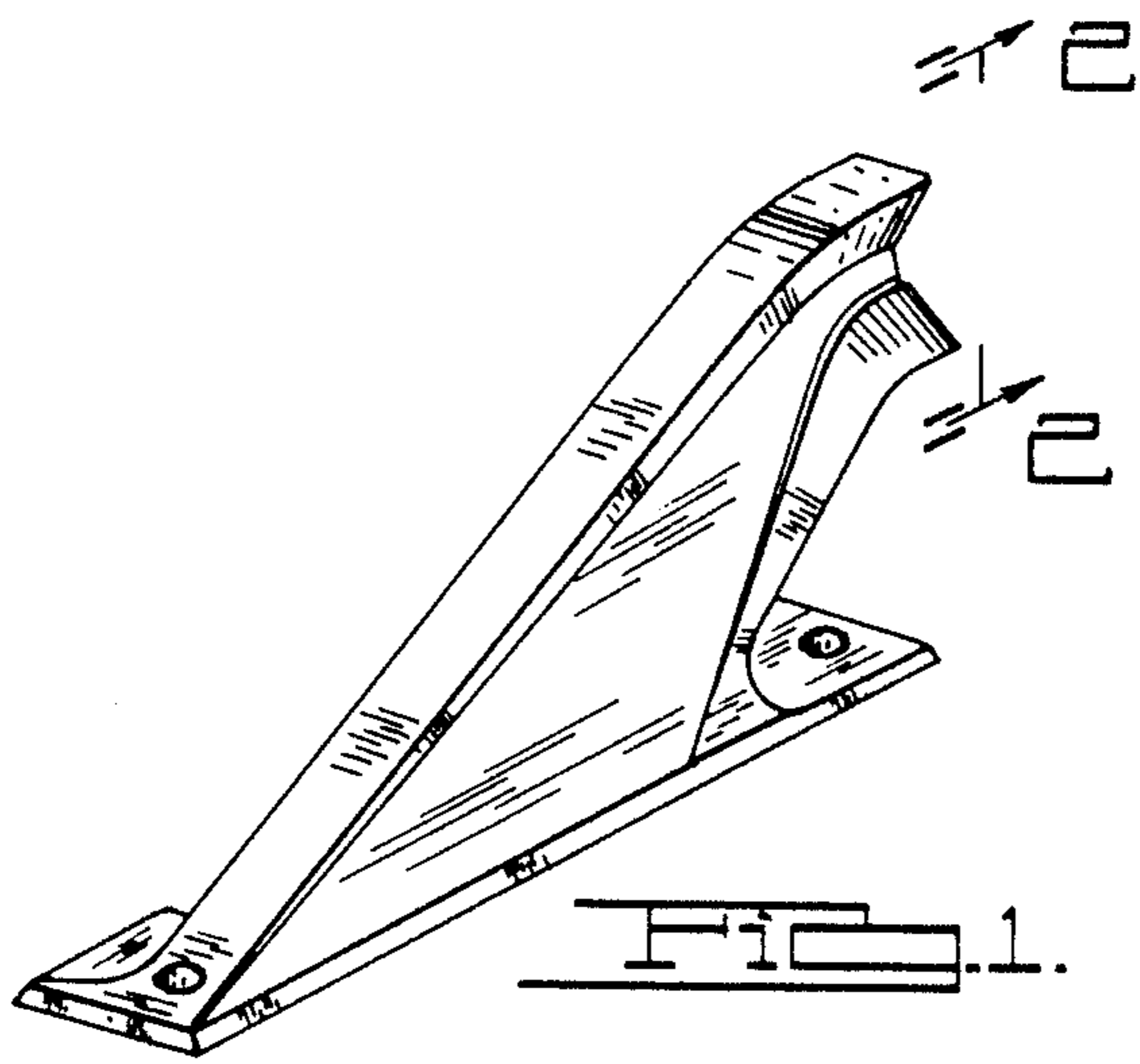

FIG. 3.

FIG. 4.

FIG. 5.

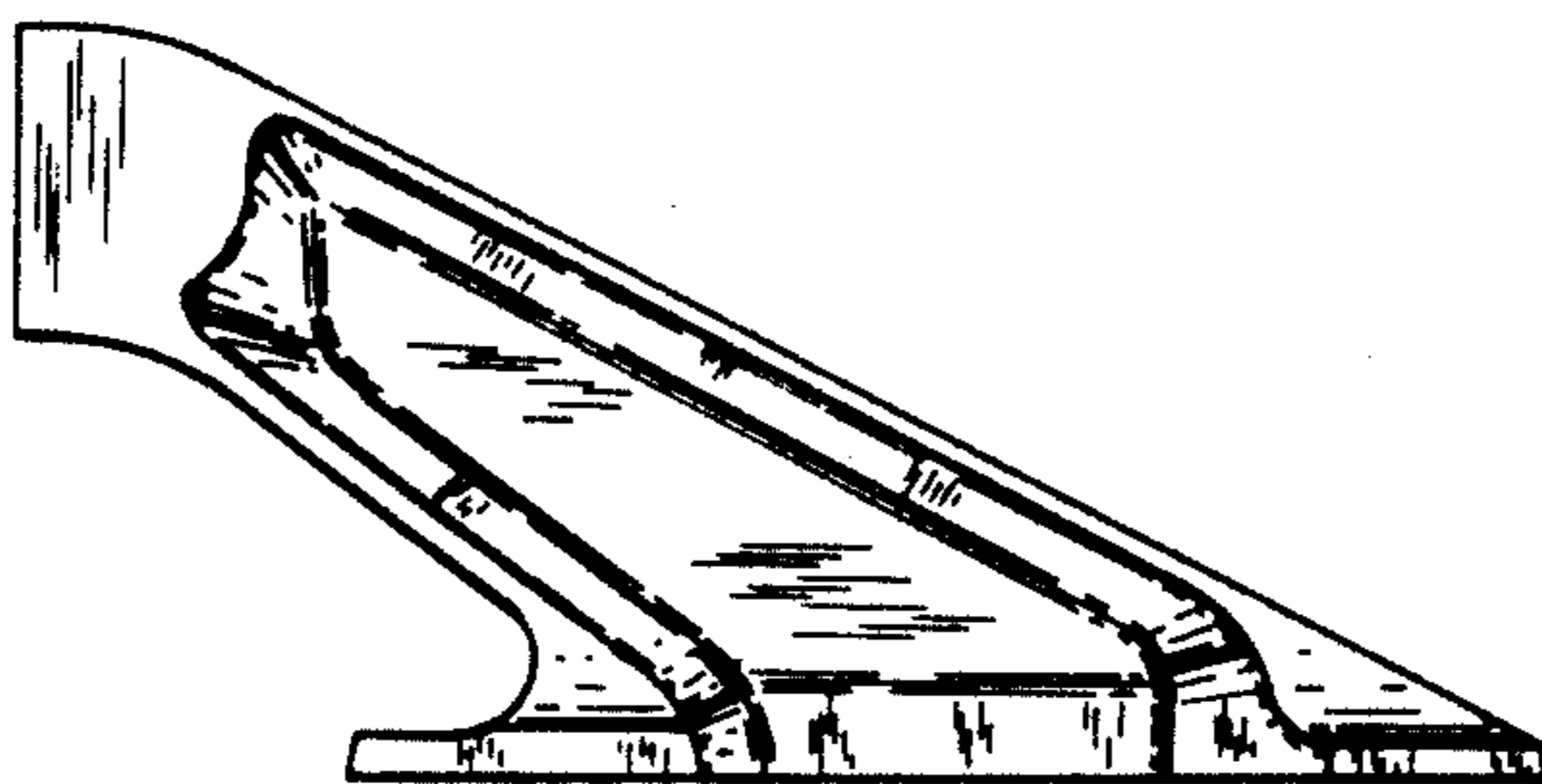

FIG. 6.