

[54] TOY MOLDING MACHINE

[76] Inventors: Fredric C. Behling, 41 Washington St., West Barrington, R.I. 02890; Paul J. Sullivan, 300 Metacom Ave., Bristol, R.I. 02809

[**] Term: 14 Years

[21] Appl. No.: 733,467

[22] Filed: Oct. 18, 1976

[51] Int. Cl. D21-01
[52] U.S. Cl. D34/15 S; D34/15 R; D34/15 T
[58] Field of Search D34/15 R, 15 S, 15 T; D15/135, 136, 122; 46/1 R, 39, 40

[56] References Cited

U.S. PATENT DOCUMENTS
1,258,845 3/1918 Wilkins 46/40

FOREIGN PATENT DOCUMENTS
353,386 6/1905 France 46/39

OTHER PUBLICATIONS

Modern Plastics, 5-1962, p. 30, Steel Drum Tumbler at top of page.
Ward 1965 Toy Yearbook, 1965, p. 295, Vac-U-Form Set at bottom of page.

Primary Examiner—Joel Stearman
Assistant Examiner—C. A. Rademaker
Attorney, Agent, or Firm—Elliot A. Salter

[57] CLAIM

The ornamental design for a toy molding machine, substantially as shown and described.

DESCRIPTION

FIG. 1 is a perspective view of a toy molding machine showing our new design;
FIG. 2 is a top plan view thereof shown on an enlarged scale;
FIG. 3 is a front elevational view thereof;
FIG. 4 is an end elevational view, looking from the left with respect to FIG. 3 shown on an enlarged scale;
FIG. 5 is a bottom plan view thereof shown on a reduced scale;
FIG. 6 is a rear elevational view thereof; and
FIG. 7 is an end elevational view looking from the right with respect to FIG. 3 shown on an enlarged scale.
Portions of the splash guard member have been shown in fragment in FIGS. 3, 4, 6 and 7 for ease of illustration.

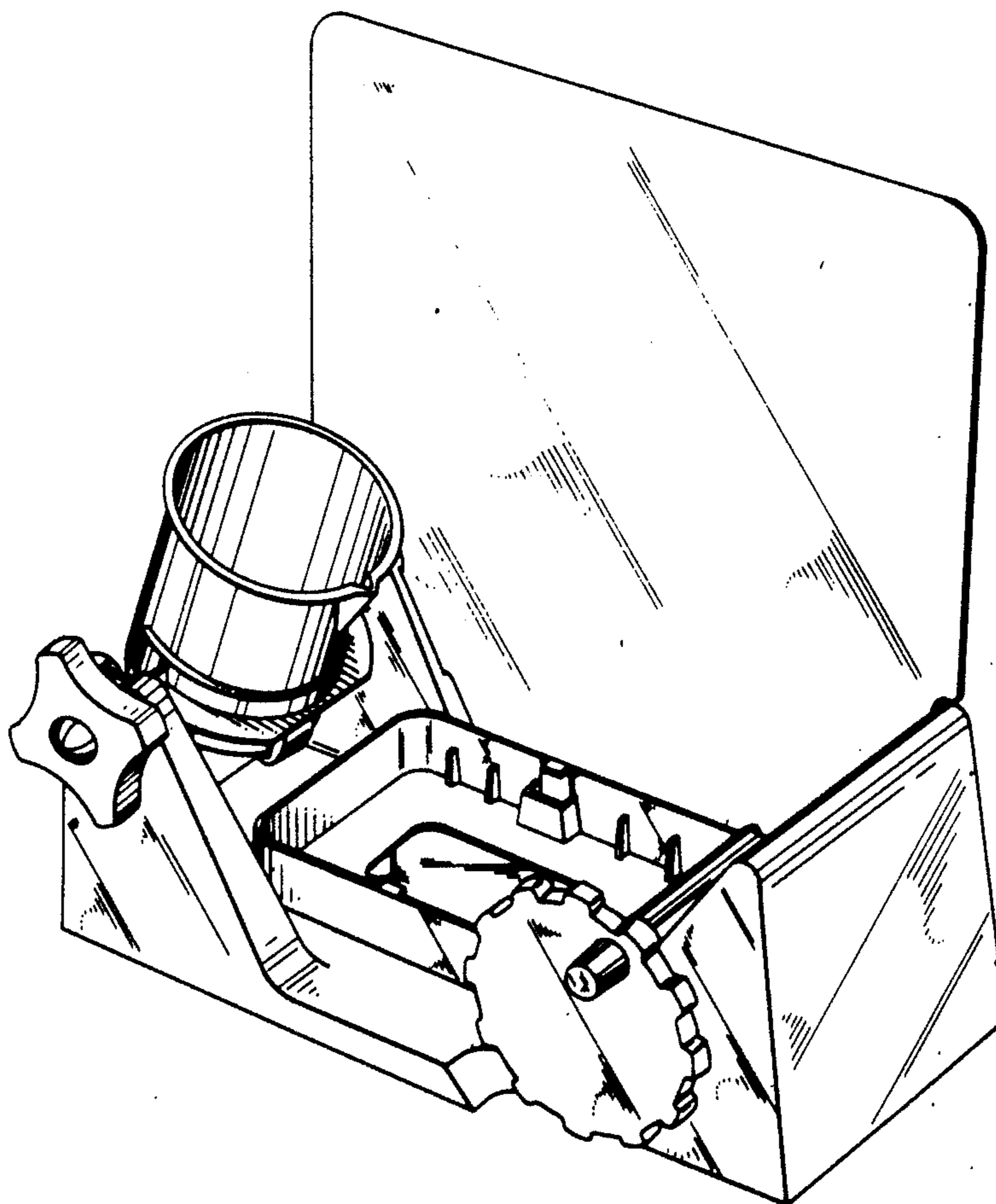

FIG. 1

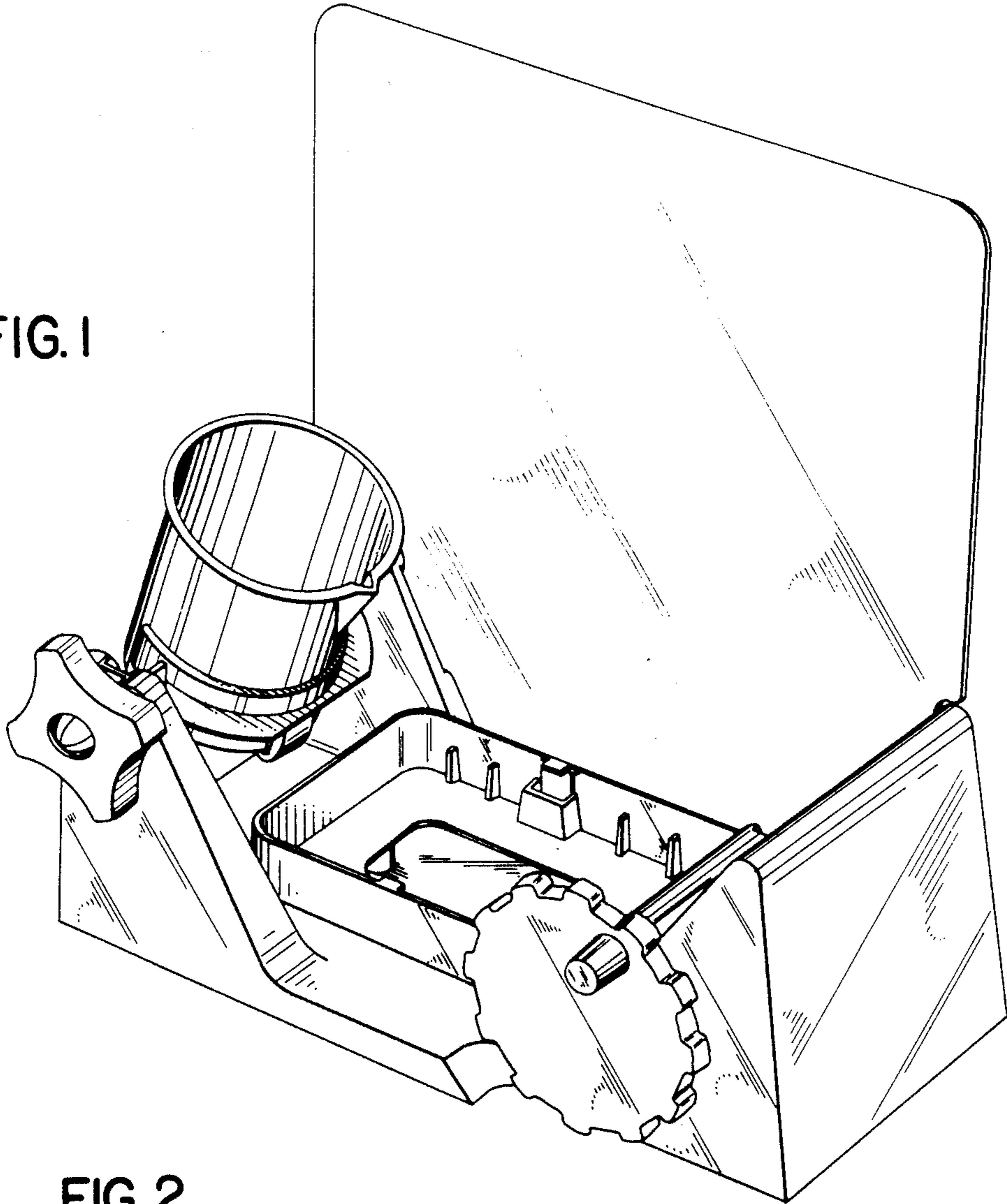
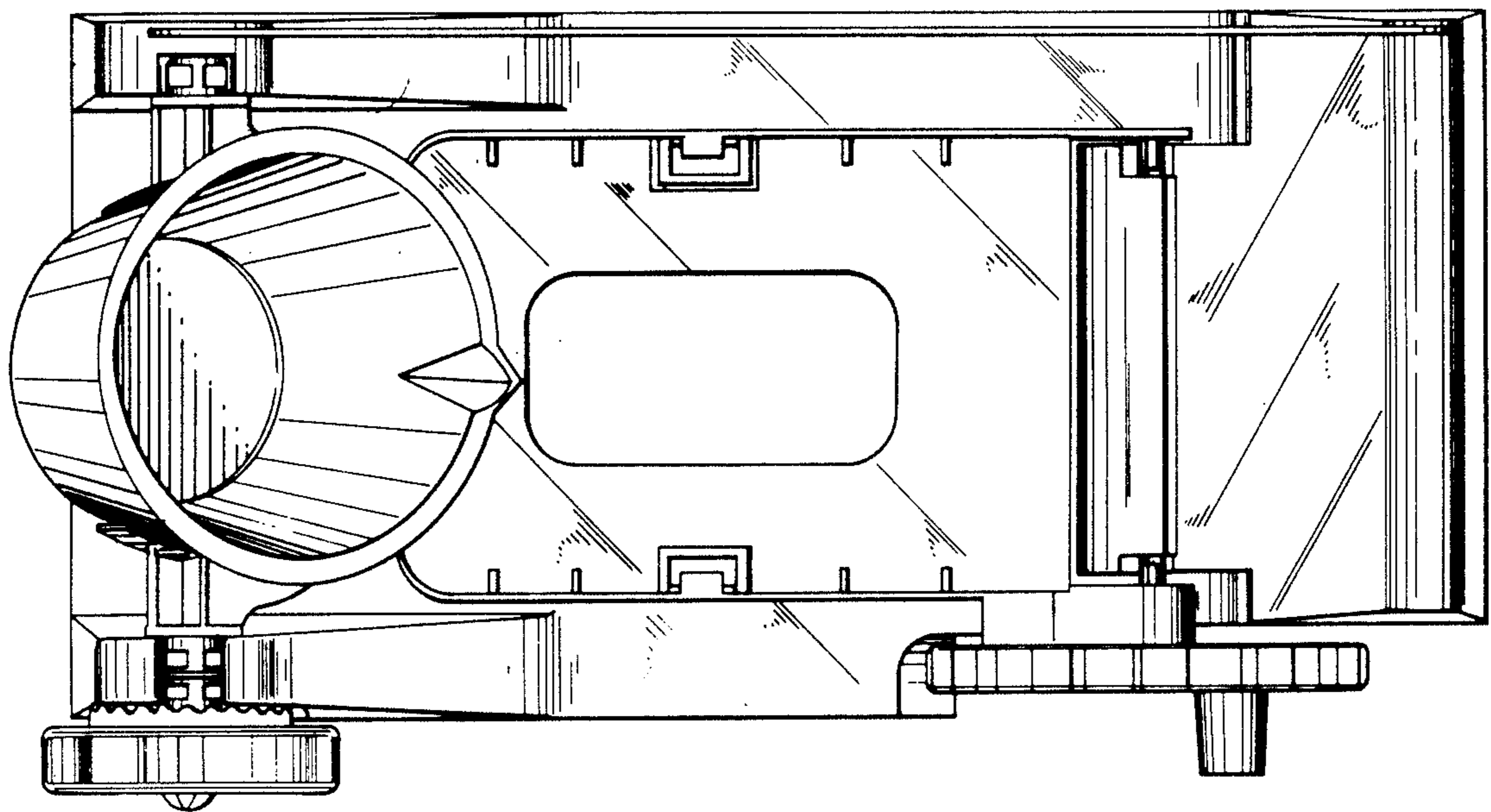

FIG. 2



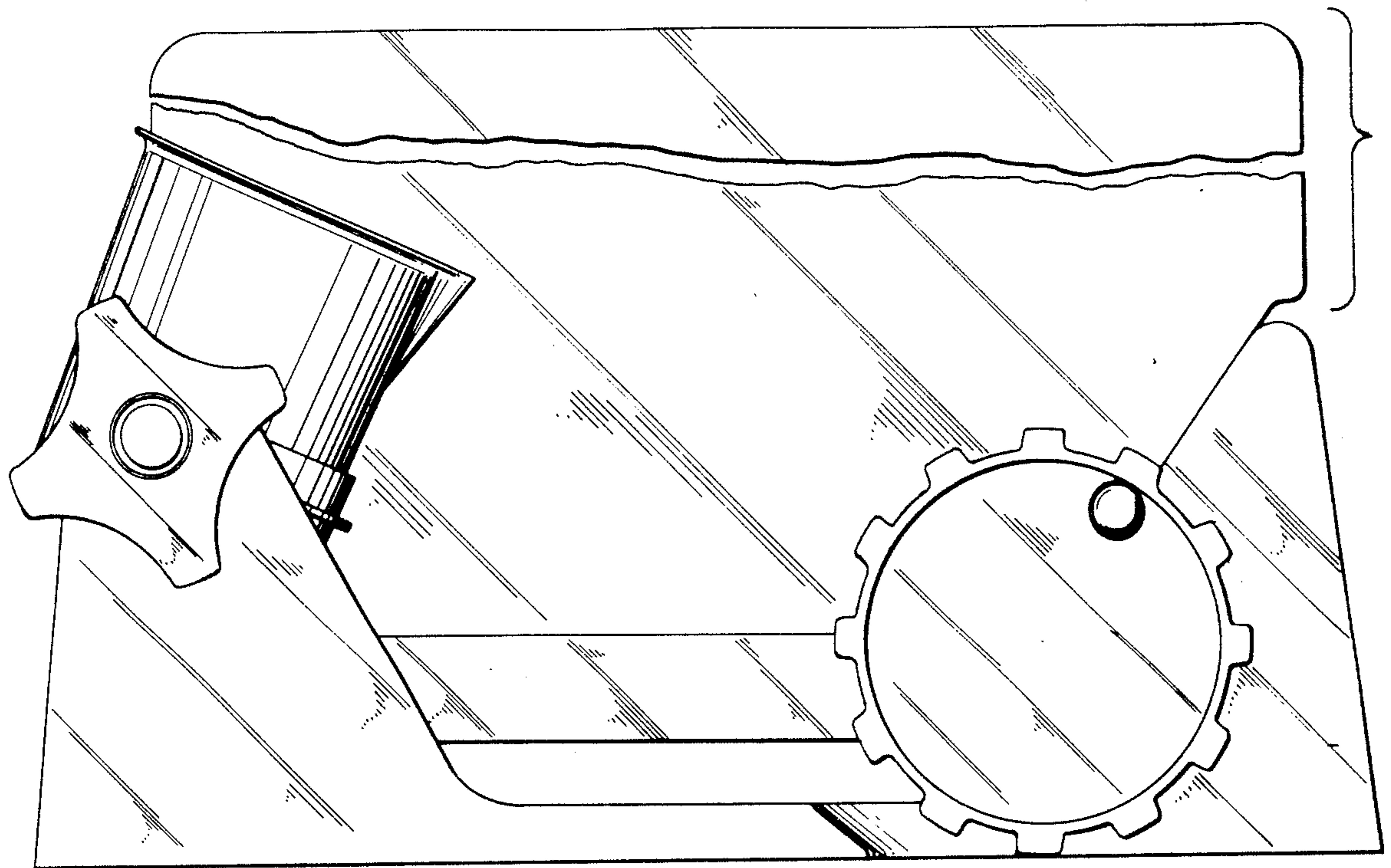

FIG. 3

FIG. 4

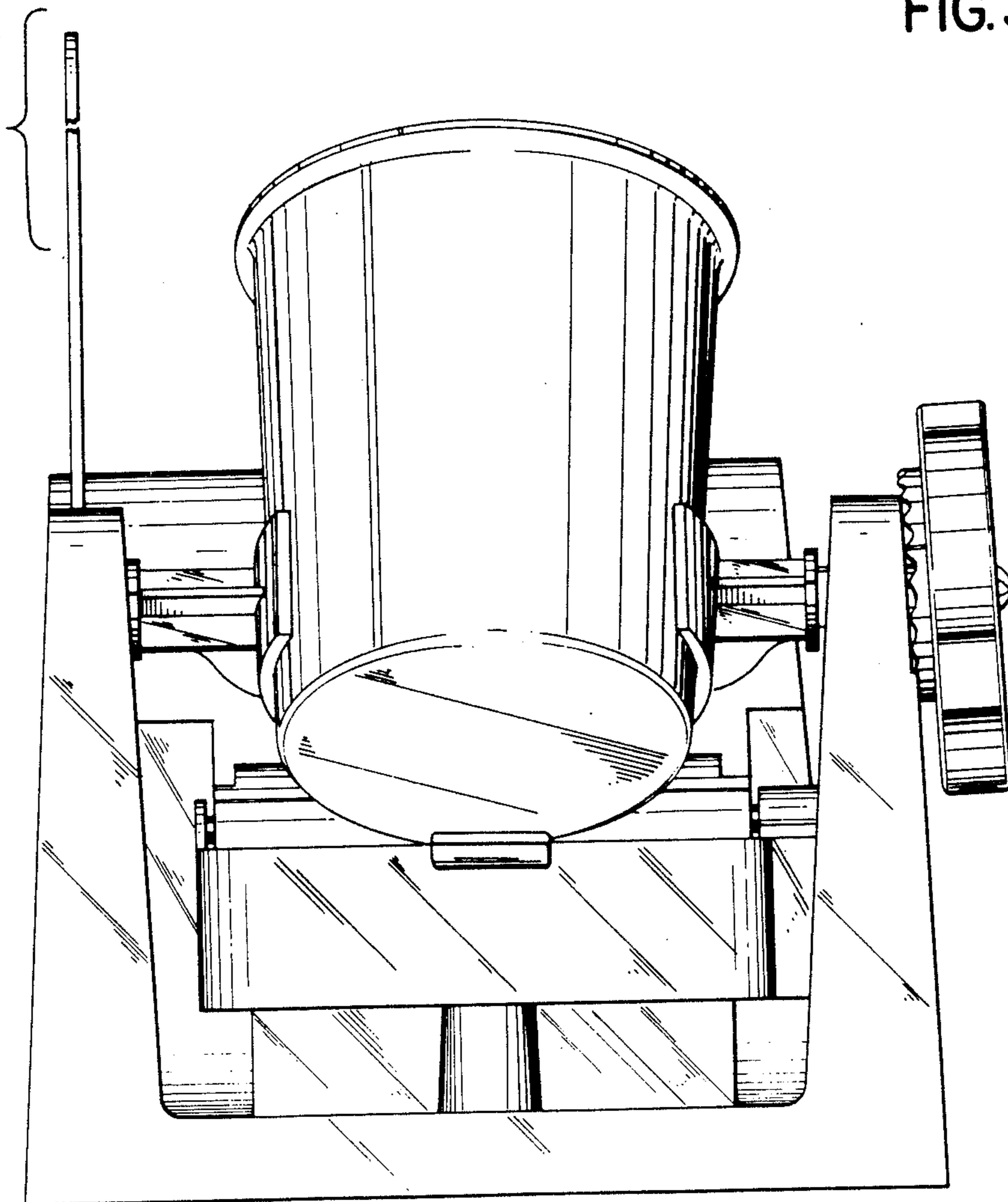

FIG. 5

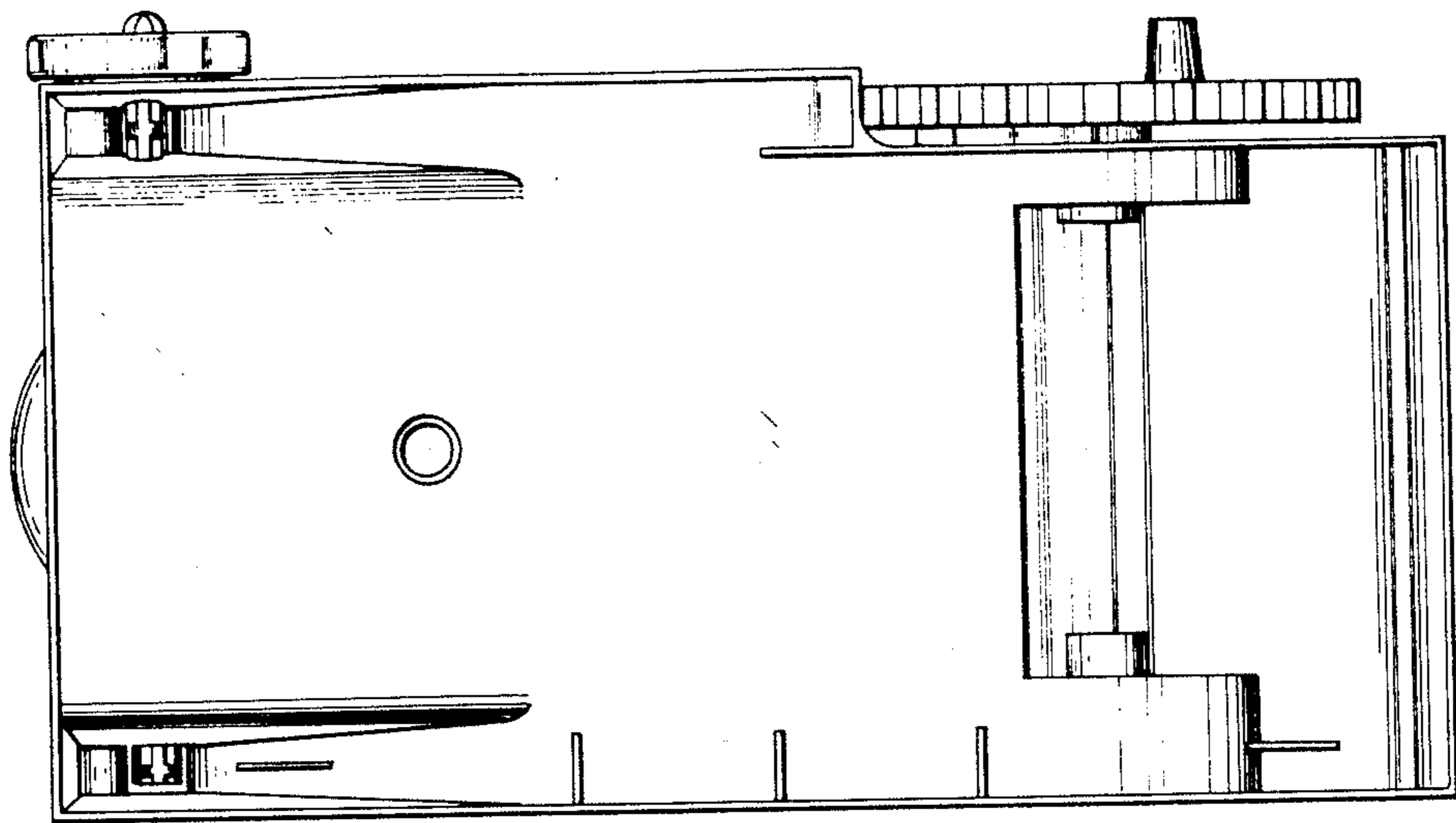

FIG. 6

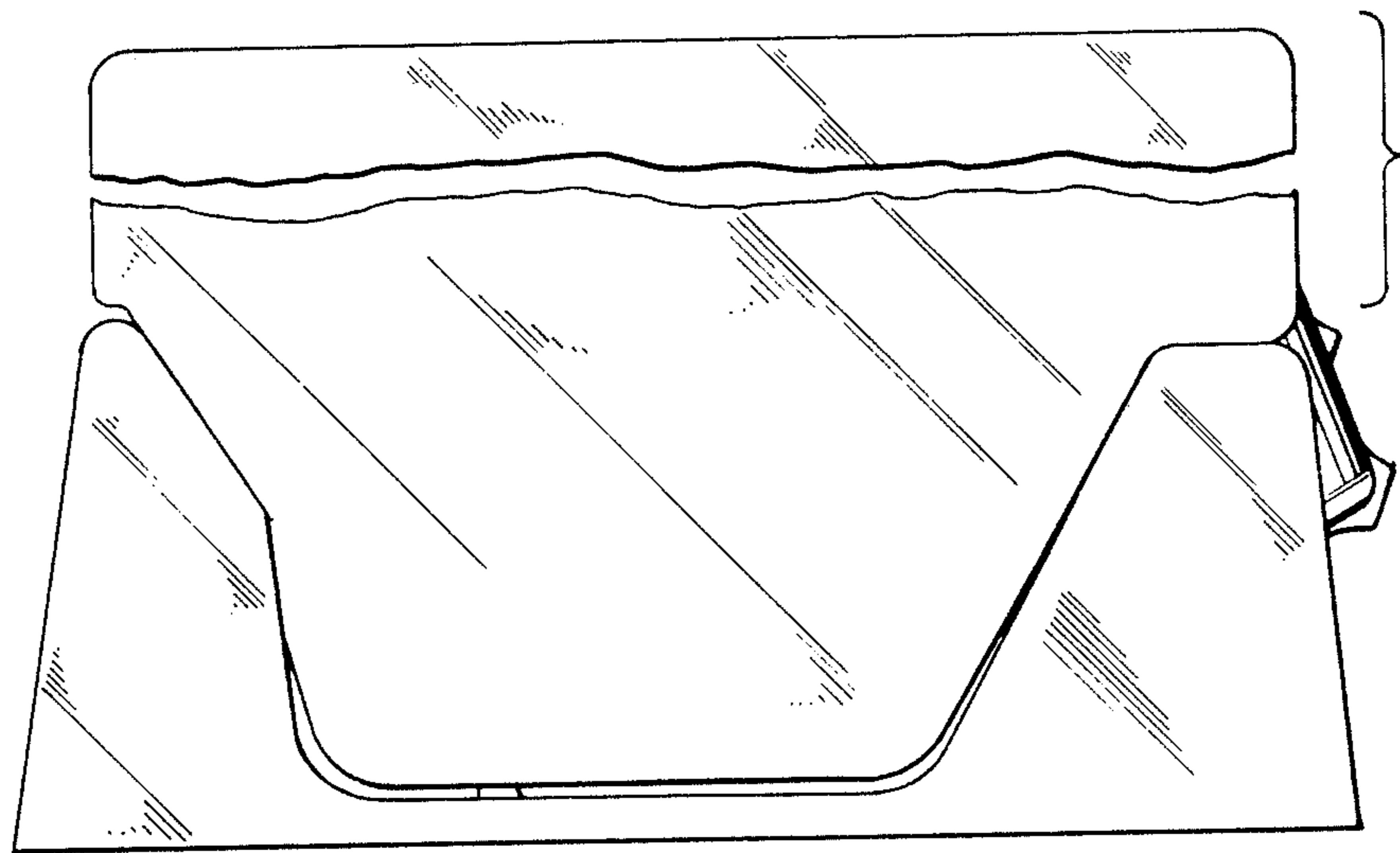

FIG. 7

