

[54] VAN TOP

[76] Inventor: Stanley G. Snyder, 1993 Belmont Ct., El Cajon, Calif. 92020

[**] Term: 14 Years

[21] Appl. No.: 855,925

[22] Filed: Nov. 30, 1977

[51] Int. Cl. D12-16

[52] U.S. Cl. D12/156

[58] Field of Search D12/89, 99, 100, 156; 296/23 MC, 23 R, 26, 137 B

[56] References Cited

U.S. PATENT DOCUMENTS

D. 203,038	11/1965	Wozena	D12/89
D. 208,151	7/1967	Long	D12/156
D. 230,019	1/1974	Cox	D12/99
D. 232,083	7/1974	Lano	D12/100

OTHER PUBLICATIONS

Popular Science, 5/77, p. 101, Van Roof, center left side of page.

Primary Examiner—James M. Gandy
Attorney, Agent, or Firm—Carl R. Brown

[57] CLAIM

The ornamental design for a van top, substantially as shown.

DESCRIPTION

FIG. 1 is a top, front and left side perspective view of a van top showing my new design, it being understood that the broken lines are for illustrative purposes only. FIG. 2 is a rear elevational view thereof to an enlarged scale; FIG. 3 is a right side elevational view thereof to an enlarged scale; FIG. 4 is a top plan view thereof to an enlarged scale; and FIG. 5 is a bottom plan view thereof to an enlarged scale.

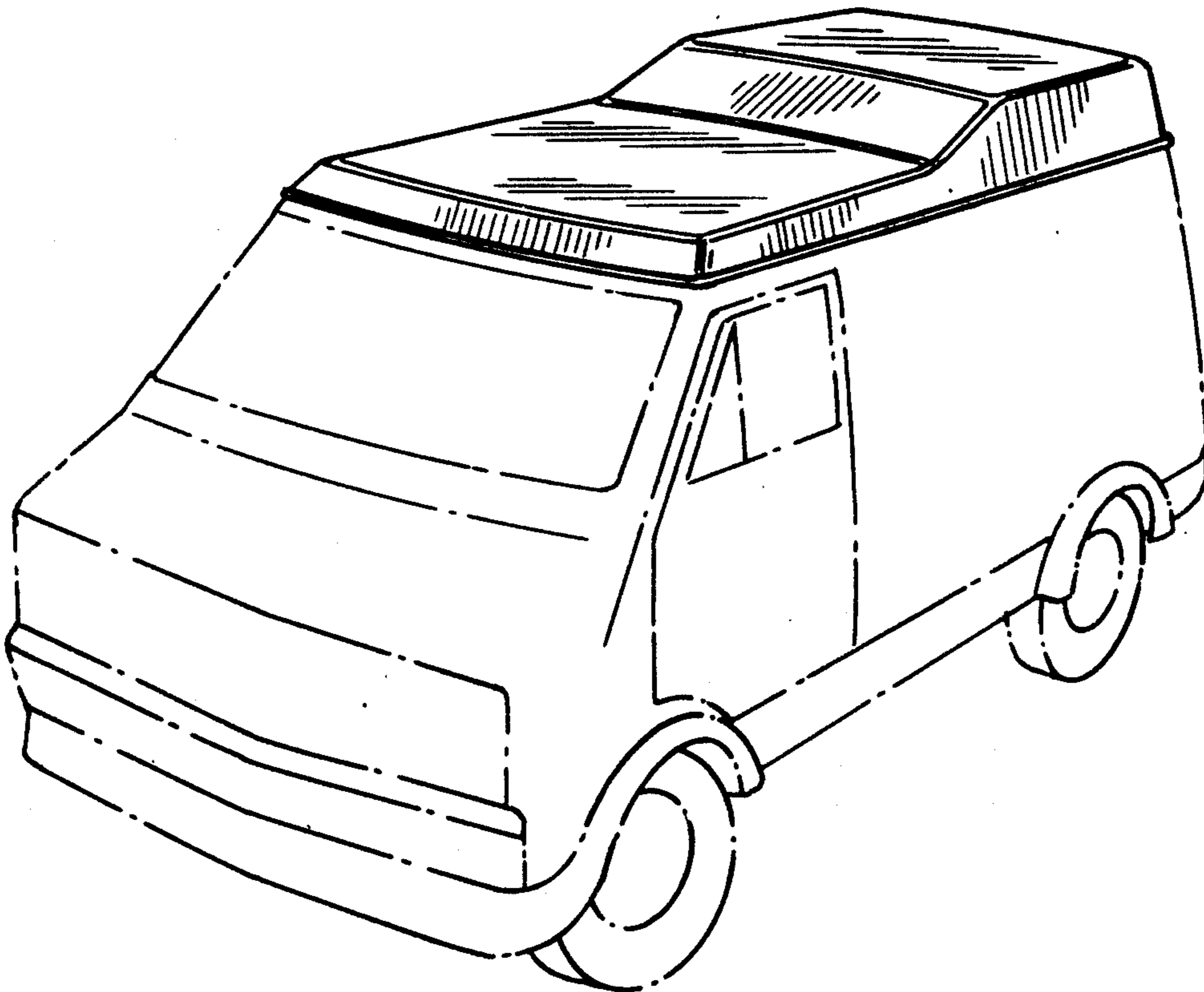

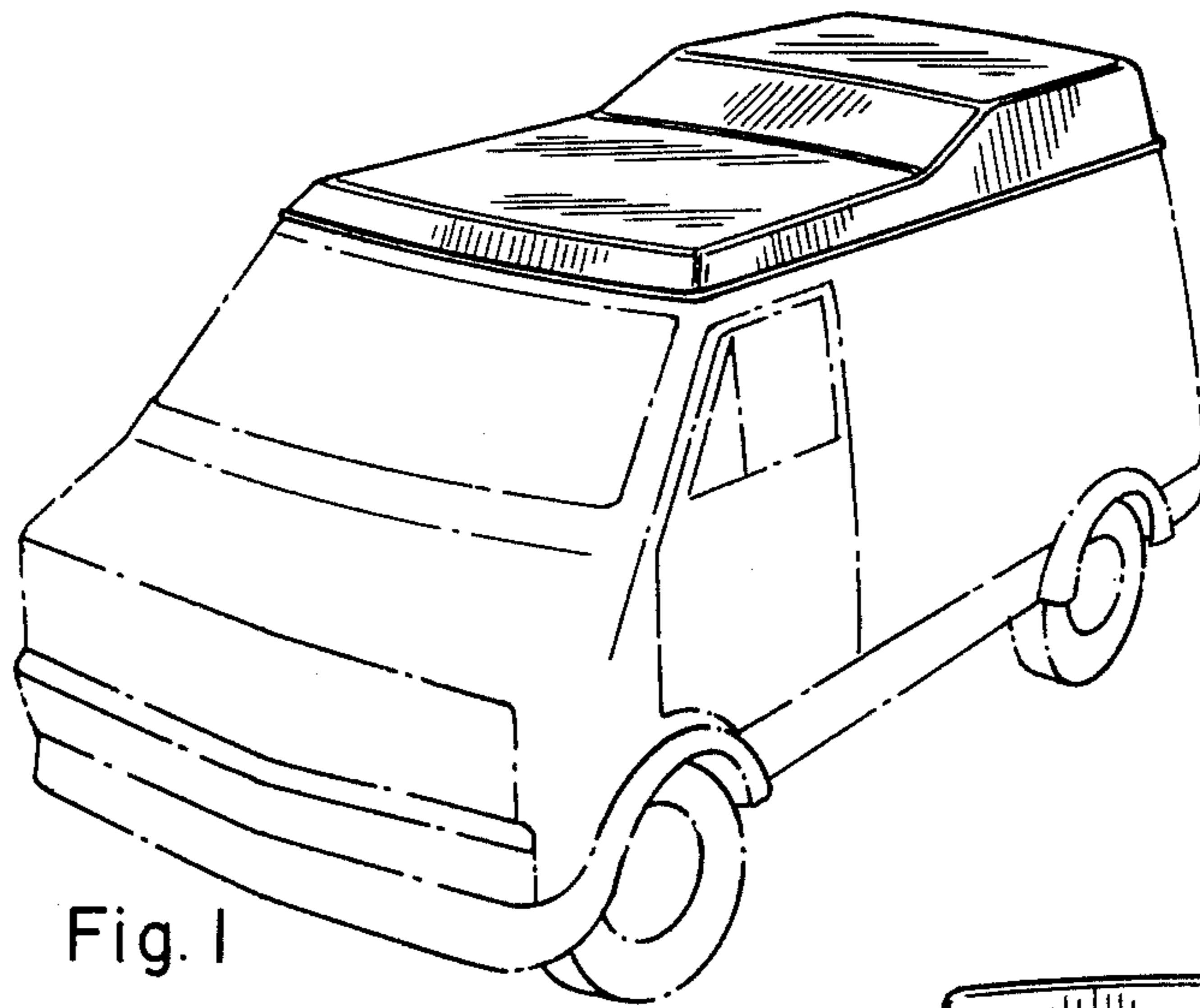

Fig. 1



Fig. 2



Fig. 3

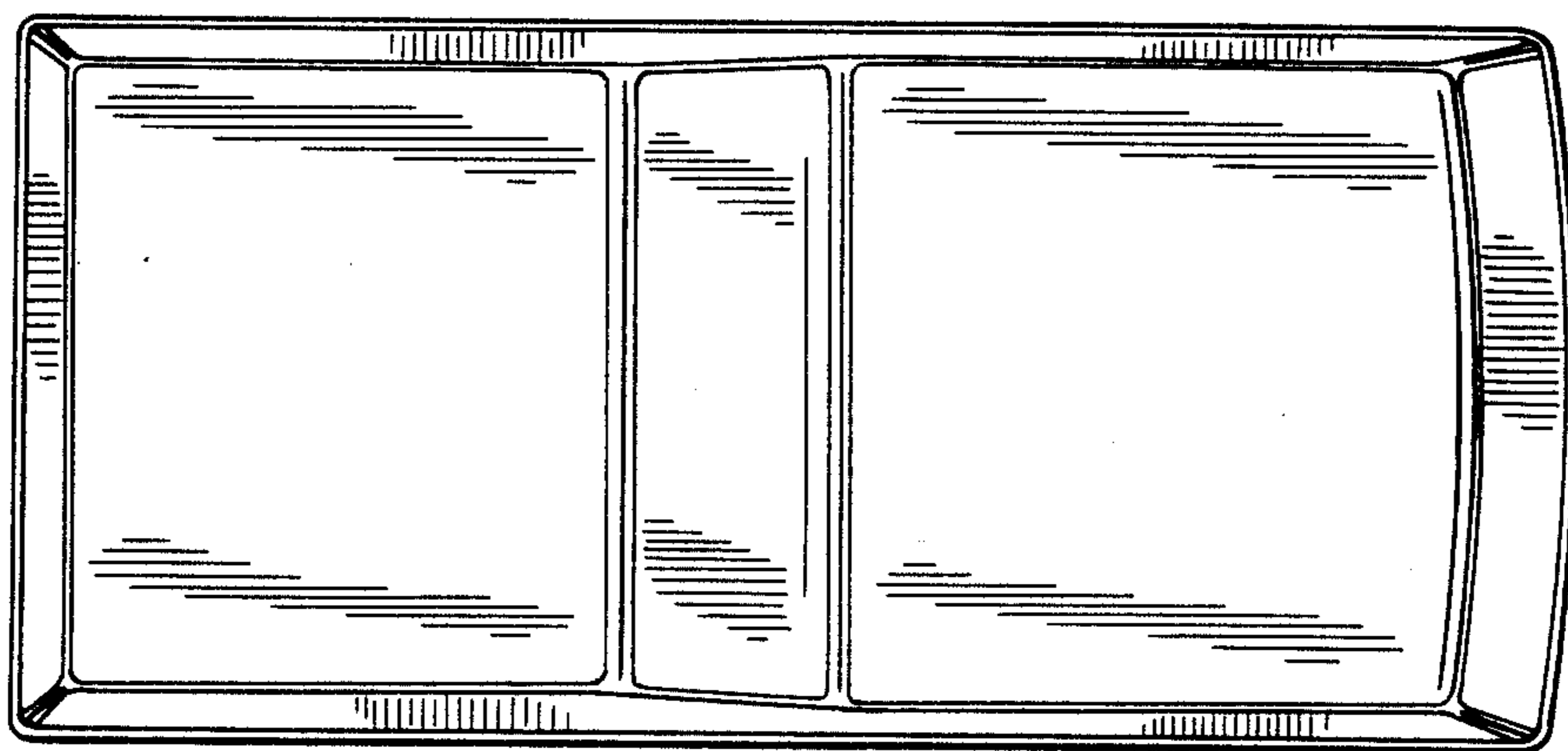

Fig. 4

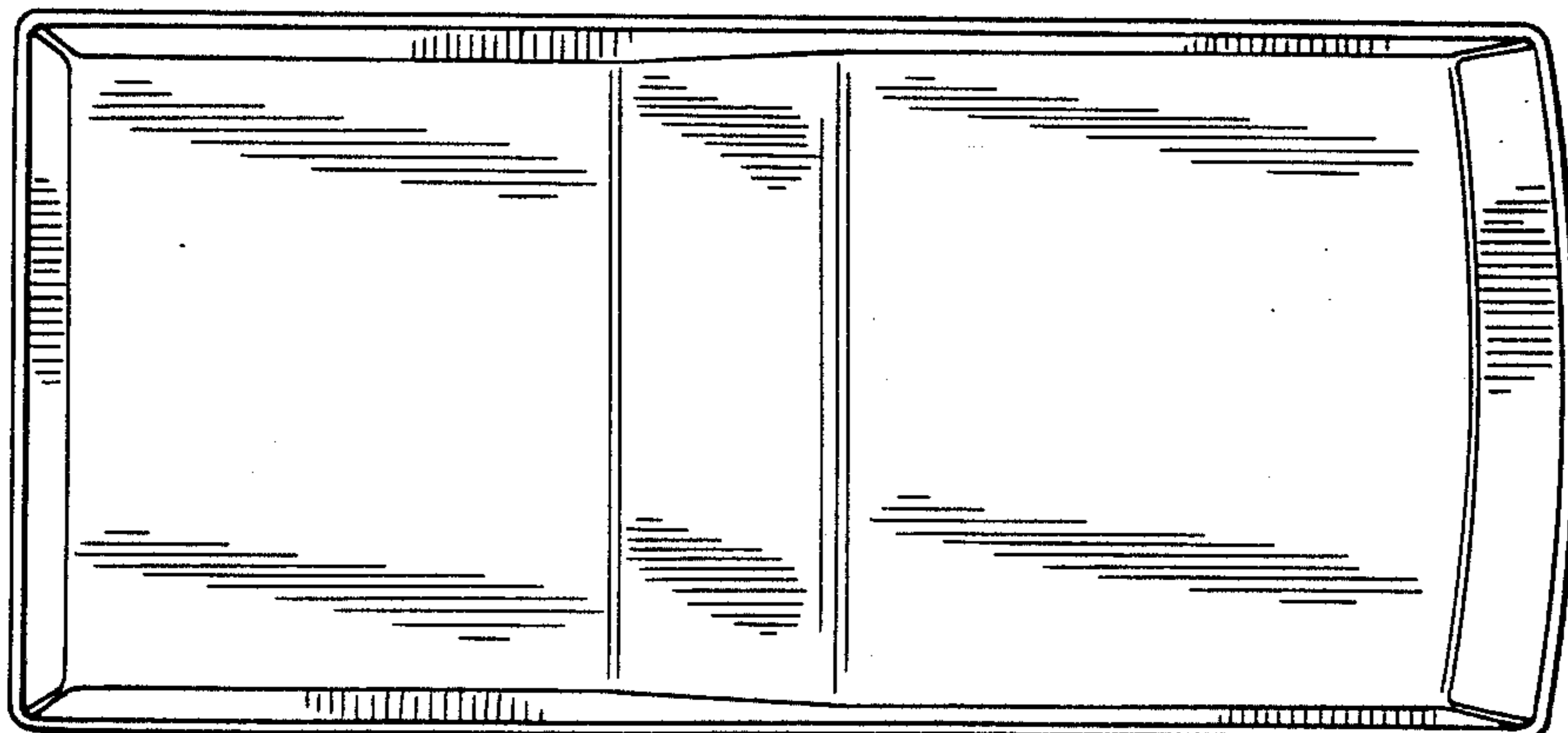

Fig. 5