

- [54] WHEEL DESIGN
- [75] Inventor: Philip G. Patch, San Juan Capistrano, Calif.
- [73] Assignee: Keystone Products, Inc., Ontario, Calif.
- [**] Term: 14 Years
- [21] Appl. No.: 840,181
- [22] Filed: Oct. 5, 1977

Related U.S. Application Data

- [63] Continuation-in-part of Ser. No. 815,888, Jul. 15, 1977, abandoned.
- [51] Int. Cl. D12-16
- [52] U.S. Cl. D12/209
- [58] Field of Search D12/209-211, D12/205; 301/63 R, 63 PW, 64 R, 64 SD, 65, 66

References Cited

U.S. PATENT DOCUMENTS

- D. 84,321 6/1931 Beutke et al. D12/209
- D. 219,015 10/1970 Reid D12/211

- D. 219,441 12/1970 Mitchell D12/211
- D. 227,453 6/1973 Phillippe D12/209
- D. 231,732 6/1974 Ishibashi D12/209
- D. 241,830 10/1976 Patch D12/211

OTHER PUBLICATIONS

Tire Review, 5/76, p. 44, wheel, bottom right side of page.
 Modern Tire Dealer, 8/74, p. 144, wheel, top right side of page.

Primary Examiner—Wallace R. Burke
 Assistant Examiner—James M. Gandy
 Attorney, Agent, or Firm—Louis J. Knobbe

CLAIM

The ornamental design for a wheel, as shown and described.

DESCRIPTION

FIG. 1 is a top front perspective view of a wheel showing my new design;
 FIG. 2 is a front elevational view thereof;
 FIG. 3 is a bottom rear perspective view thereof;
 FIG. 4 is a rear elevational view thereof; and
 FIG. 5 is a sectional view taken along line 5-5 in FIG. 2.

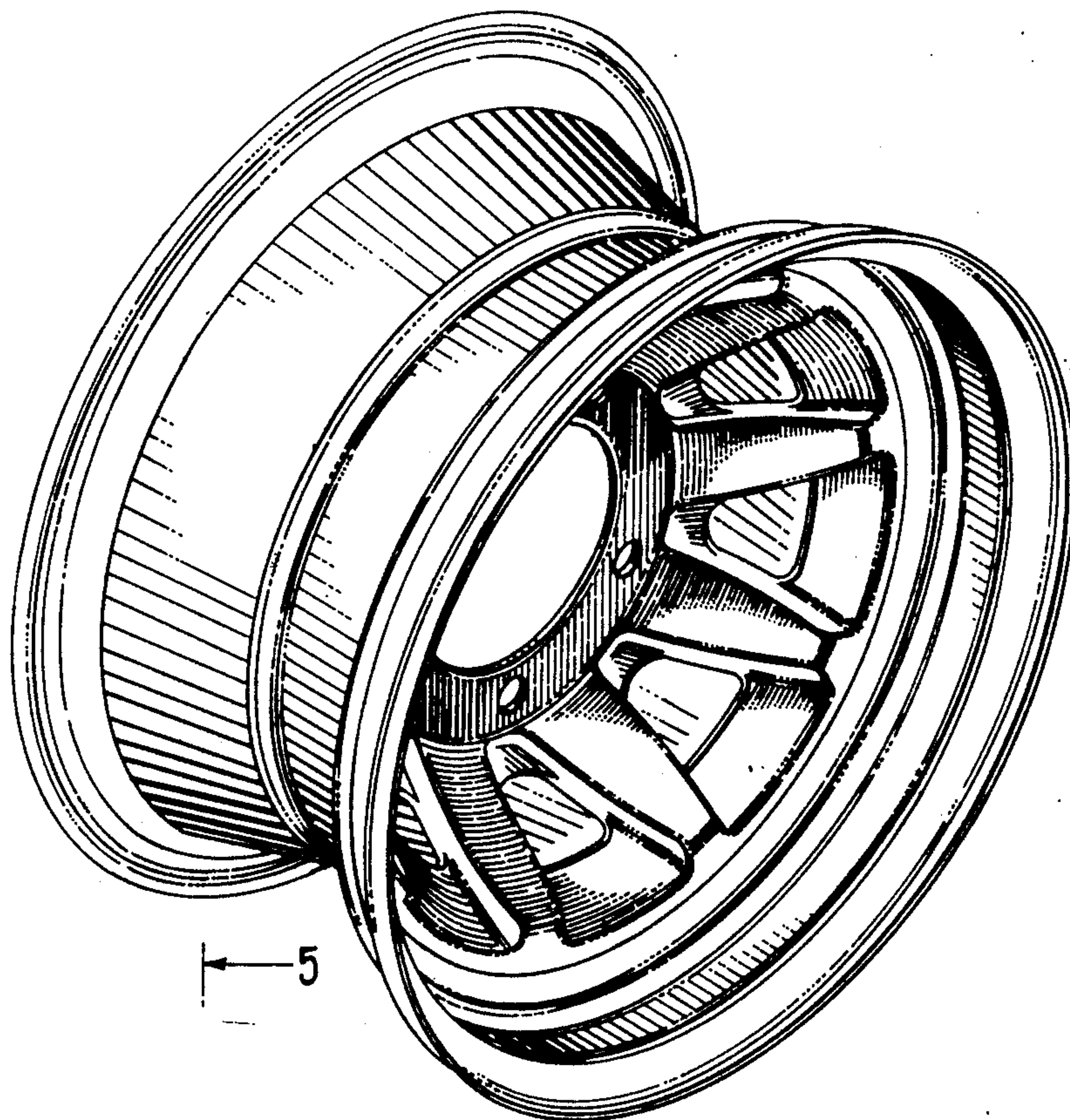

FIG. 1.

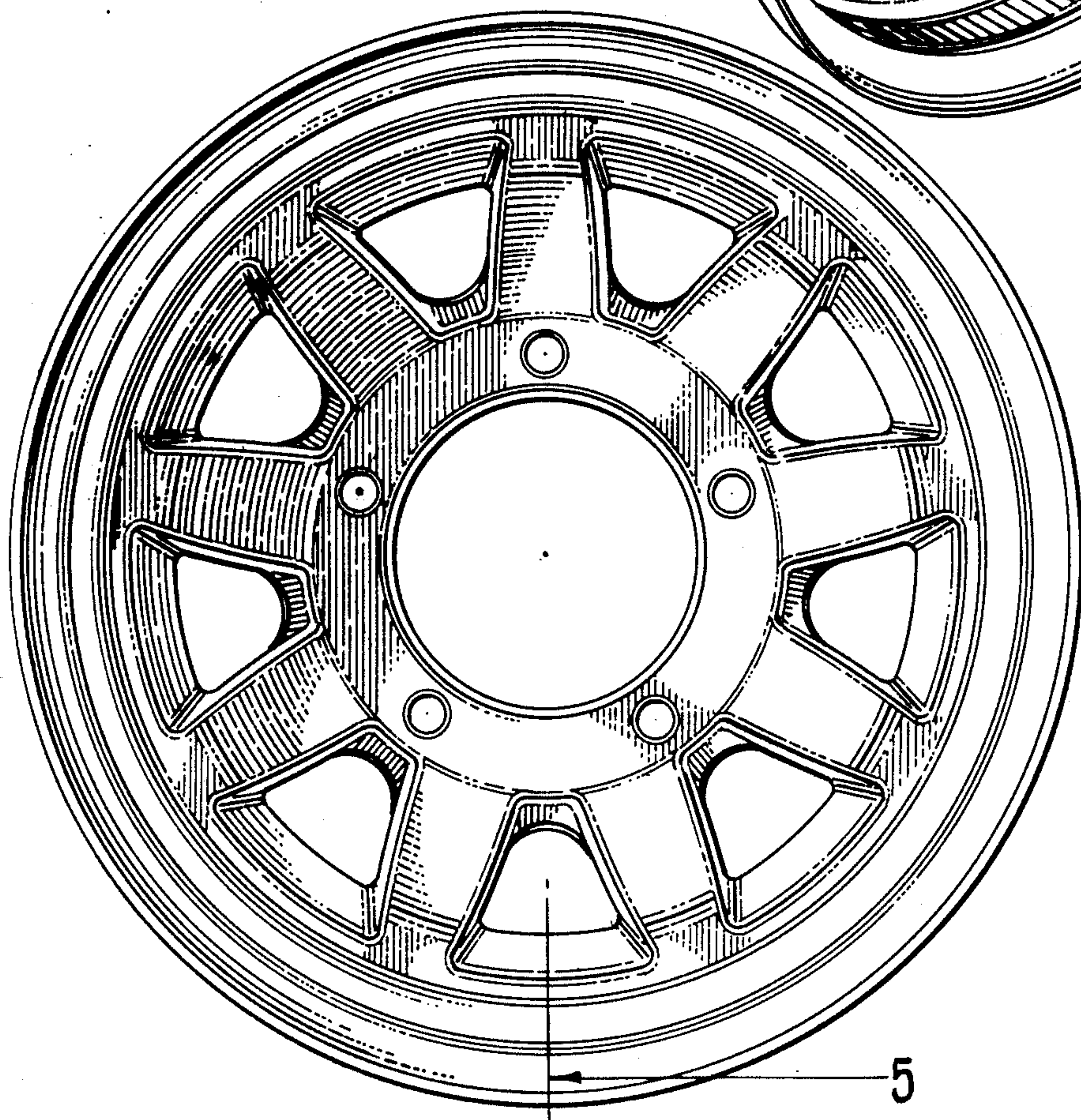
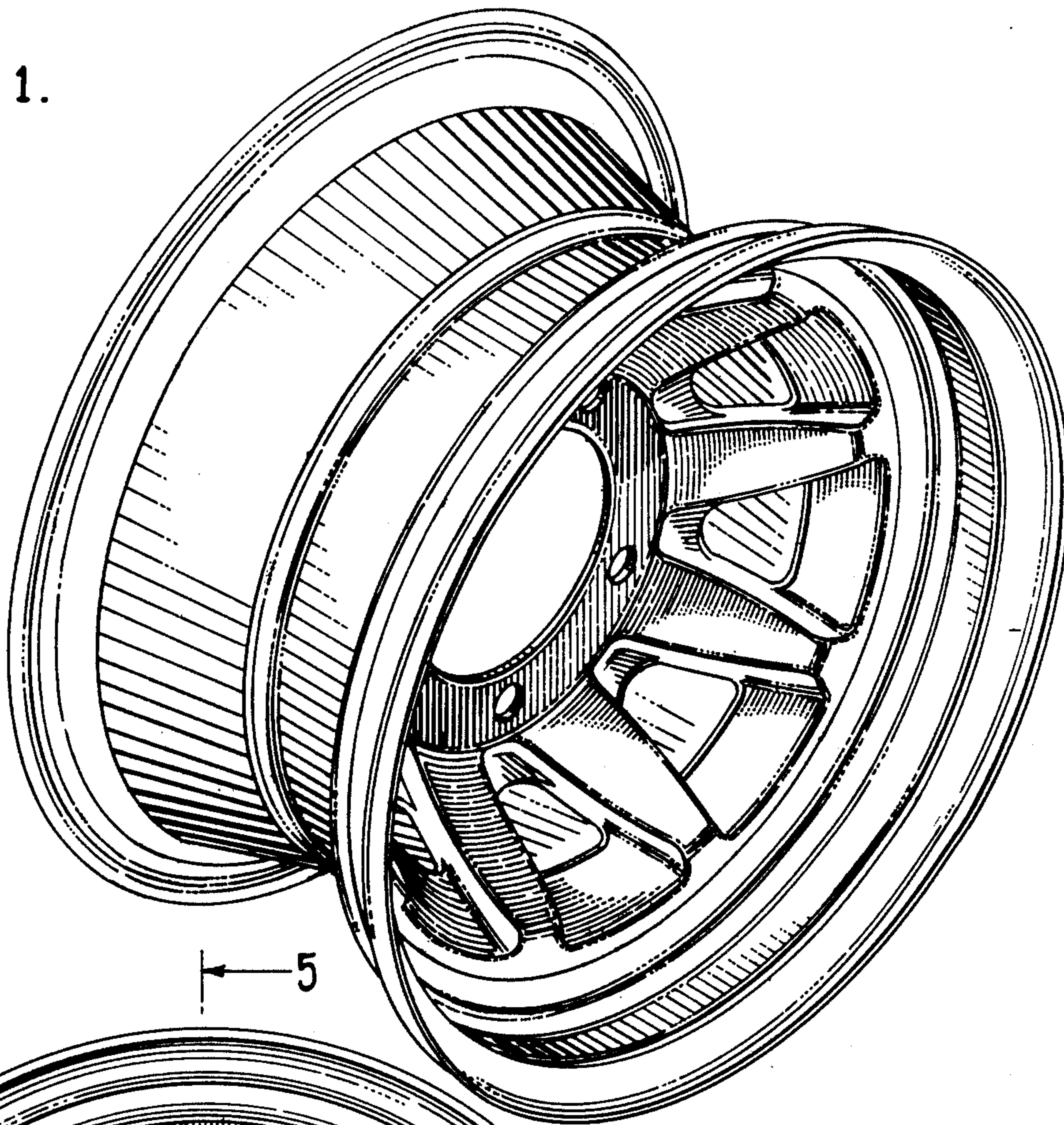

FIG. 2.

FIG. 3.

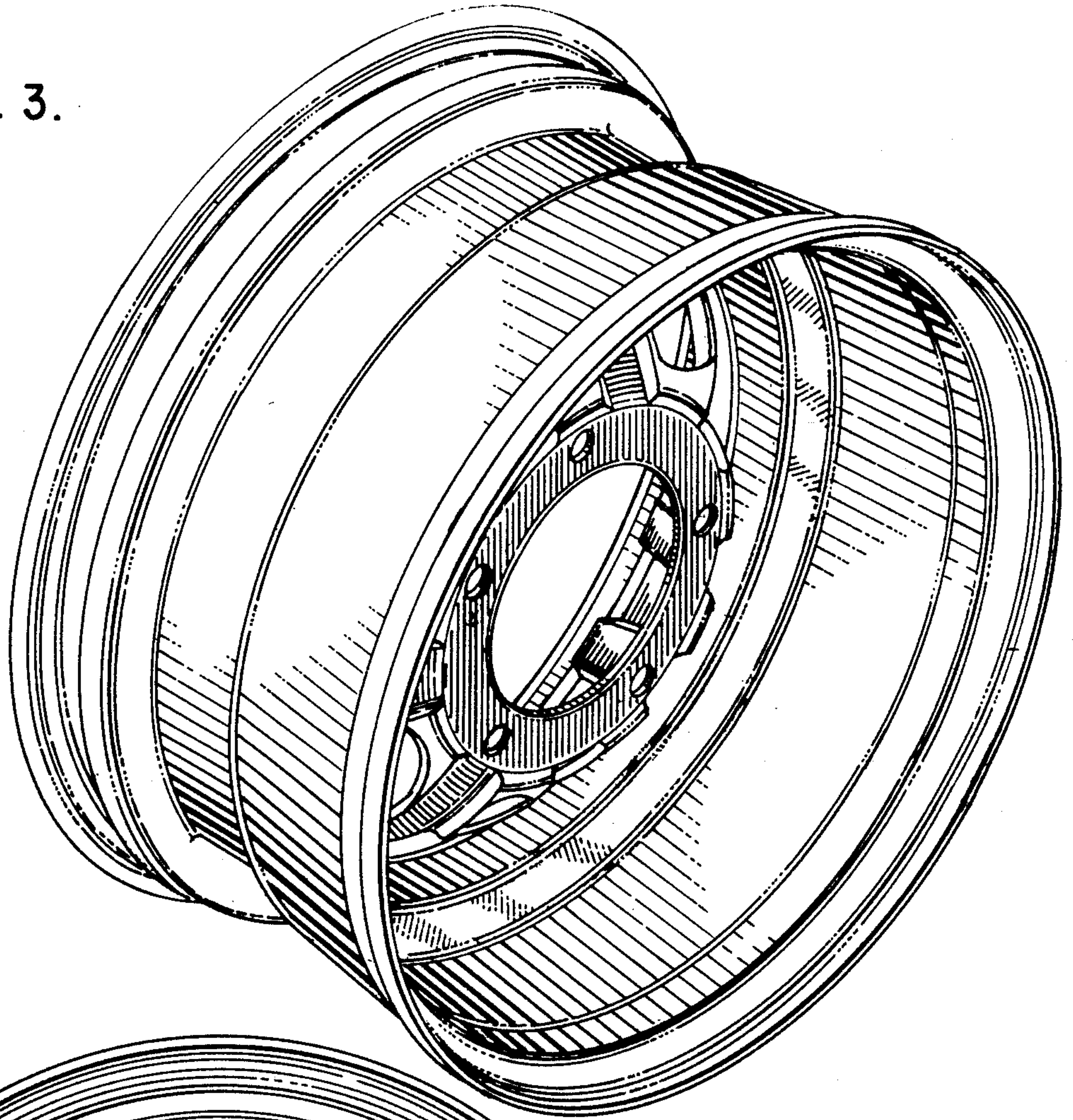

FIG. 4.

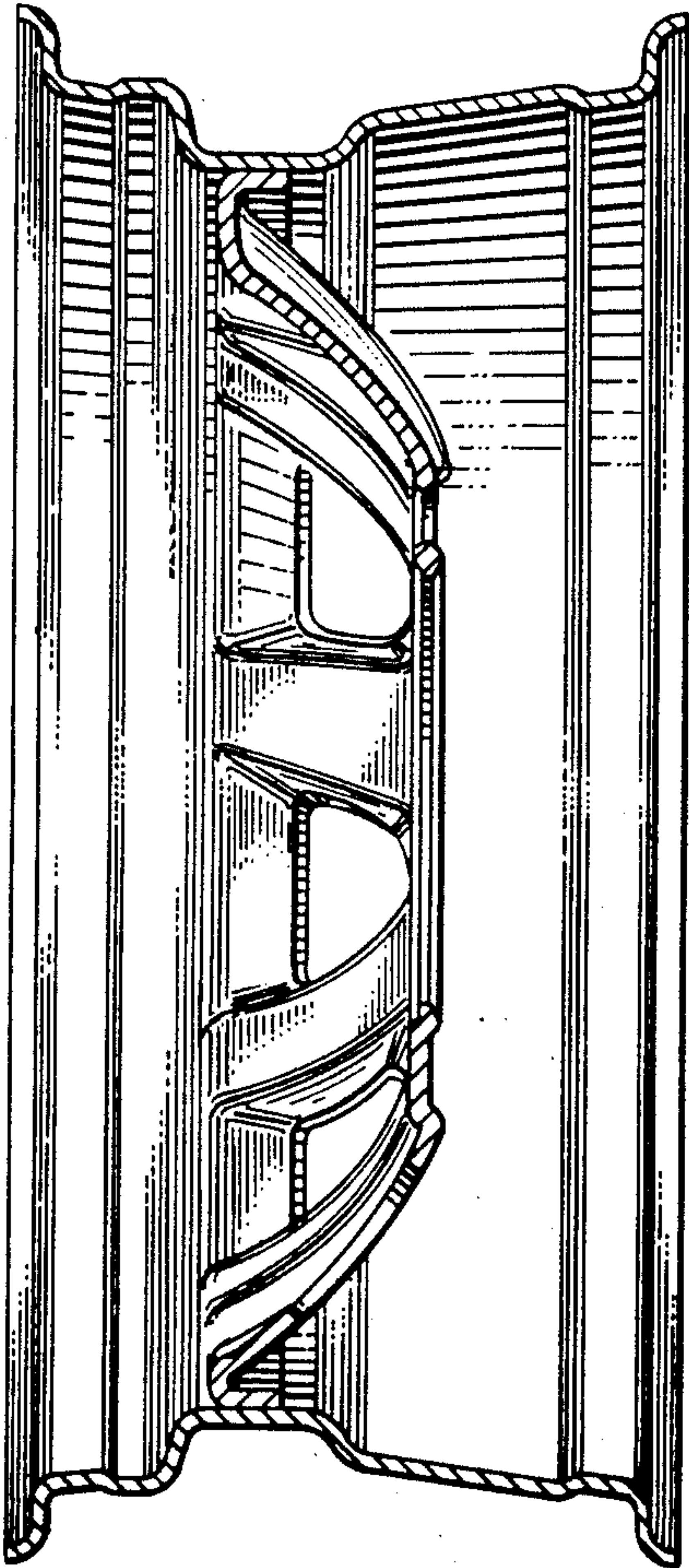

FIG. 5.