

[54] VAN TRAY

[76] Inventor: Daniel J. Bradley, 10207 NE. 143rd,
Bothell, Wash. 98011

[**] Term: 14 Years

[21] Appl. No.: 796,467

[22] Filed: May 12, 1977

[51] Int. Cl. D12-16

[52] U.S. Cl. D87/1 R; D6/85;
D6/188; D7/38; D7/71

[58] Field of Search D12/155; D87/1 R;
D7/38, 71; 224/29 R, 29 H, 42.11, 42.42 R,
42.42 A, 42.45 R, 48 R, 46 T; 108/44, 47, 48;
296/37.8, 37.13, 37.14, 37.15, 37.16, 37.1;
D6/199, 85, 188

[56]

References Cited

U.S. PATENT DOCUMENTS

D. 211,202	5/1968	Stageberg	D7/38
D. 246,277	11/1977	Forselius	D7/71
3,233,940	2/1966	Tooley, Jr.	D7/38

OTHER PUBLICATIONS

J. C. Whitney Catalog No. 348, p. 130, Center console
to fit 58-75 Volkswagen, lower right side of page.

Primary Examiner—Wallace R. Burke
Assistant Examiner—James M. Gandy
Attorney, Agent, or Firm—Carl G. Dowrey

[57]

CLAIM

The ornamental design for a van tray, as shown.

DESCRIPTION

FIG. 1 is a perspective view of a van tray showing my
new design;
FIG. 2 is a rear elevational view thereof;
FIG. 3 is a top plan view thereof;
FIG. 4 is a bottom plan view thereof;
FIG. 5 is a side elevational view thereof.

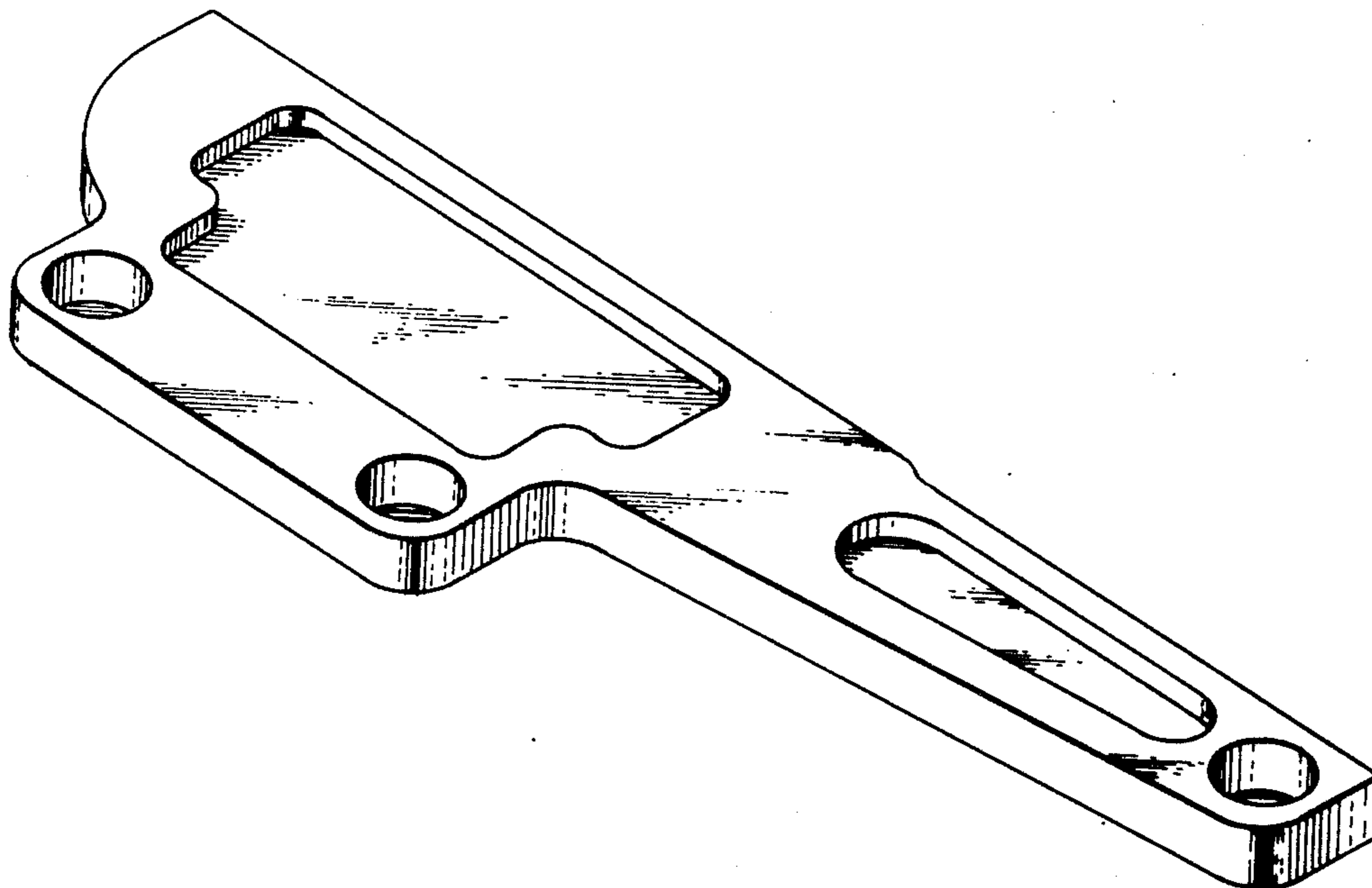

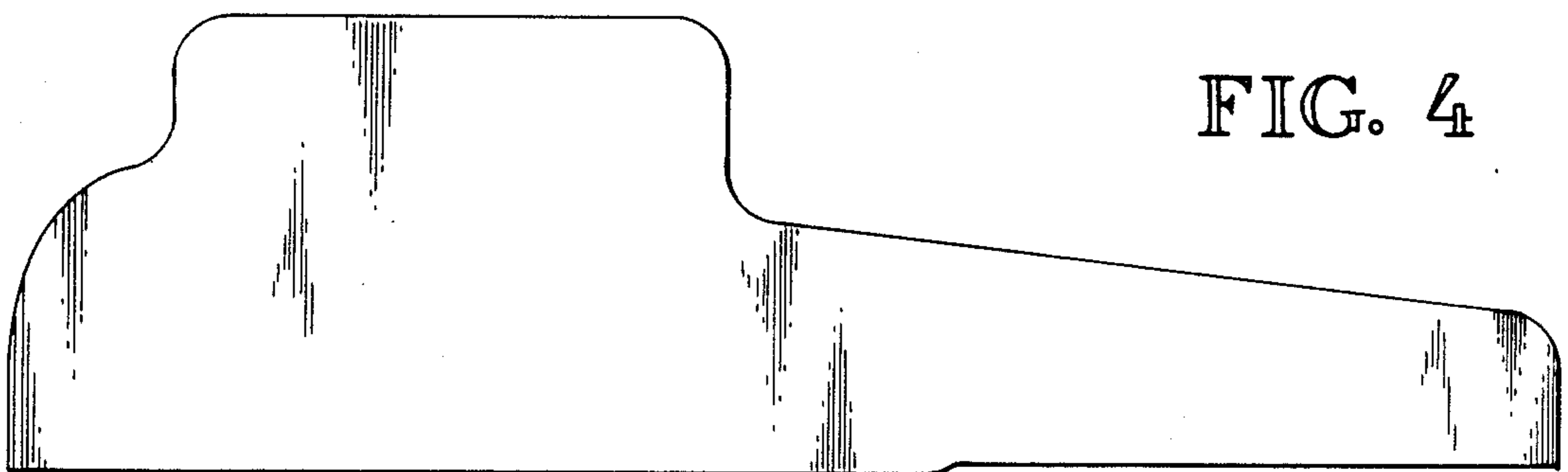
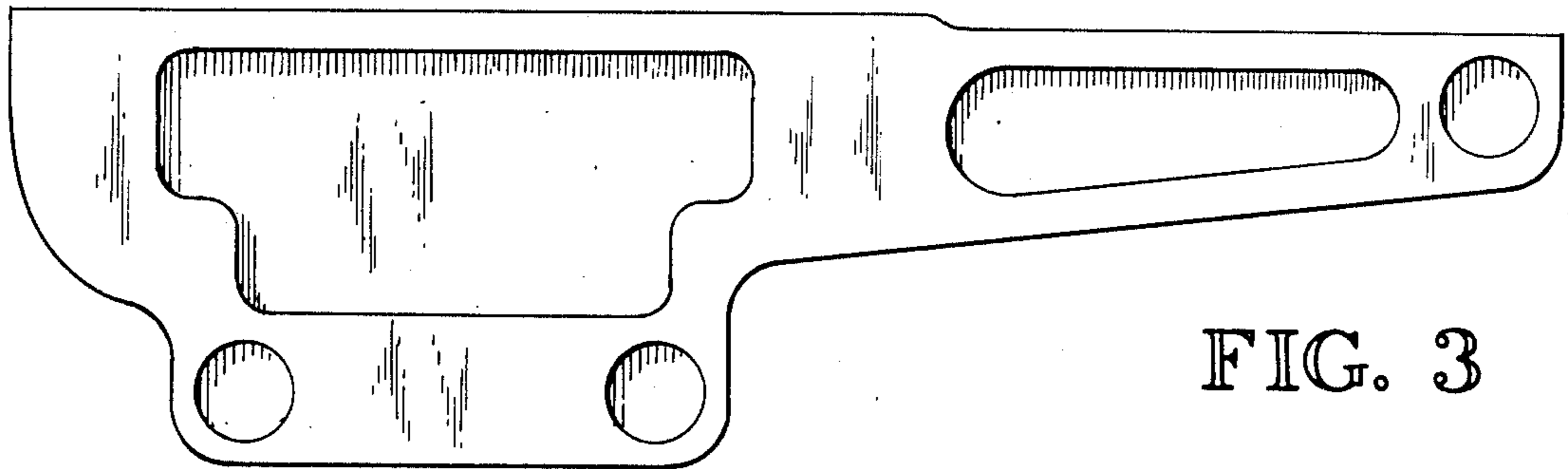
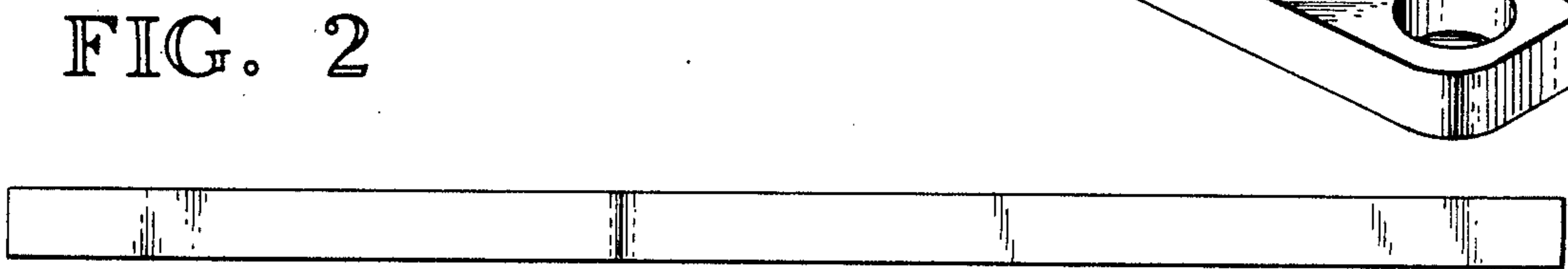
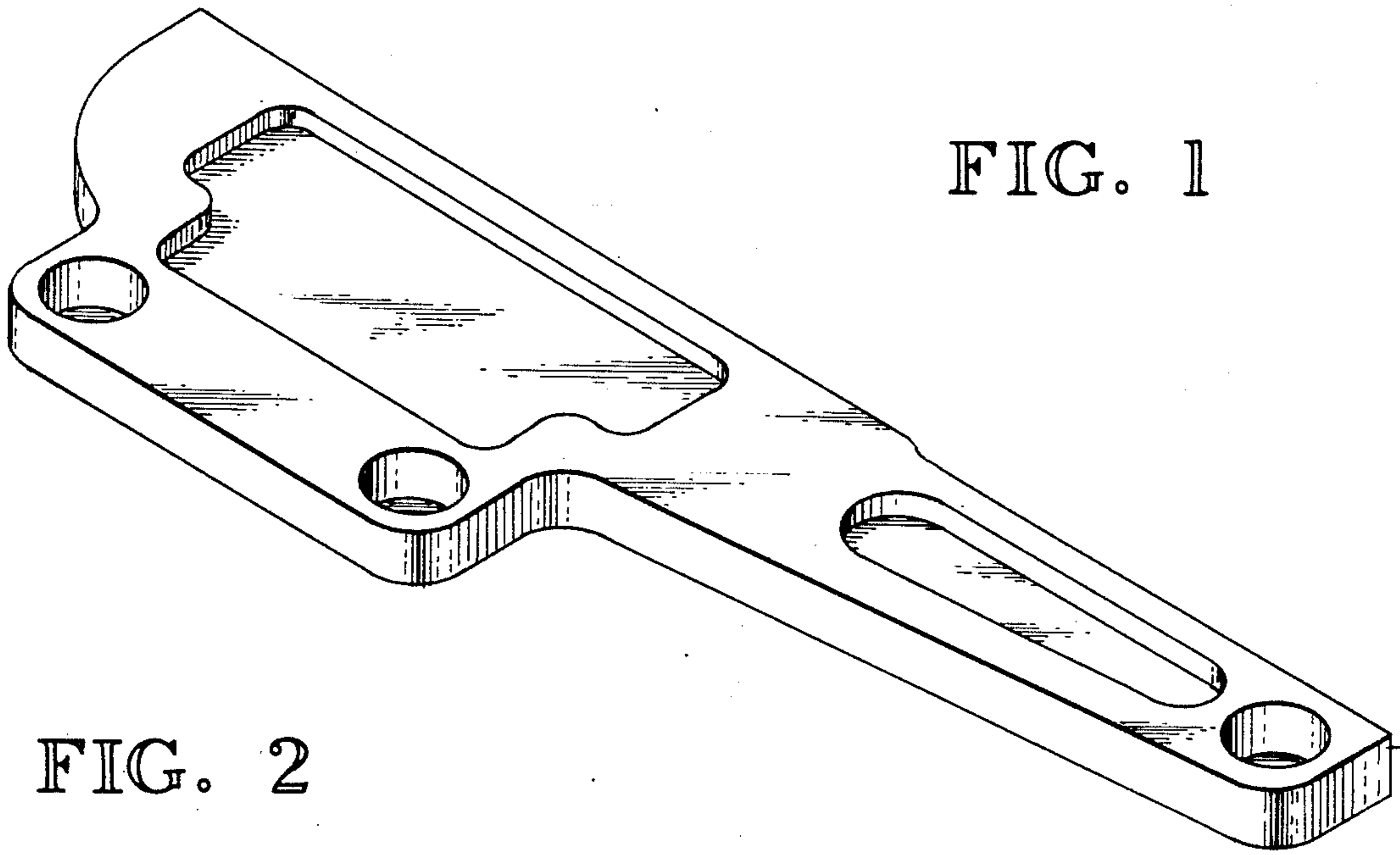

FIG. 5