

[54] TRUCK BOX

[76] Inventors: John E. Fehr; Bill L. Fehr, both of Box 1297, Morden, Canada

[**] Term: 14 Years

[21] Appl. No.: 795,665

[22] Filed: May 10, 1977

[30] Foreign Application Priority Data

Nov. 26, 1976 [CA] Canada 2611764

[51] Int. Cl. D12-16

[52] U.S. Cl. D12/98

[58] Field of Search D12/156, 98, 93; 296/10, 28 D

[56] References Cited

U.S. PATENT DOCUMENTS

D. 214,490 6/1969 Slagell D12/98

3,841,690 10/1974 Piercy 296/10
3,930,680 1/1976 Littefield 296/10

Primary Examiner—Wallace R. Burke
Assistant Examiner—James M. Gandy
Attorney, Agent, or Firm—Stanley G. Ade

[57] CLAIM

The ornamental design for a truck box, as shown and described.

DESCRIPTION

FIG. 1 is an isometric view of a truck box showing our new design;
FIG. 2 is a rear elevational view thereof;
FIG. 3 is a top plan view thereof on a reduced scale;
FIG. 4 is a bottom plan view thereof on a reduced scale;
FIG. 5 is a rear elevational view thereof with the end gates omitted for convenience of illustration.
The side opposite to that shown in FIG. 1 is substantially a mirror image thereof.

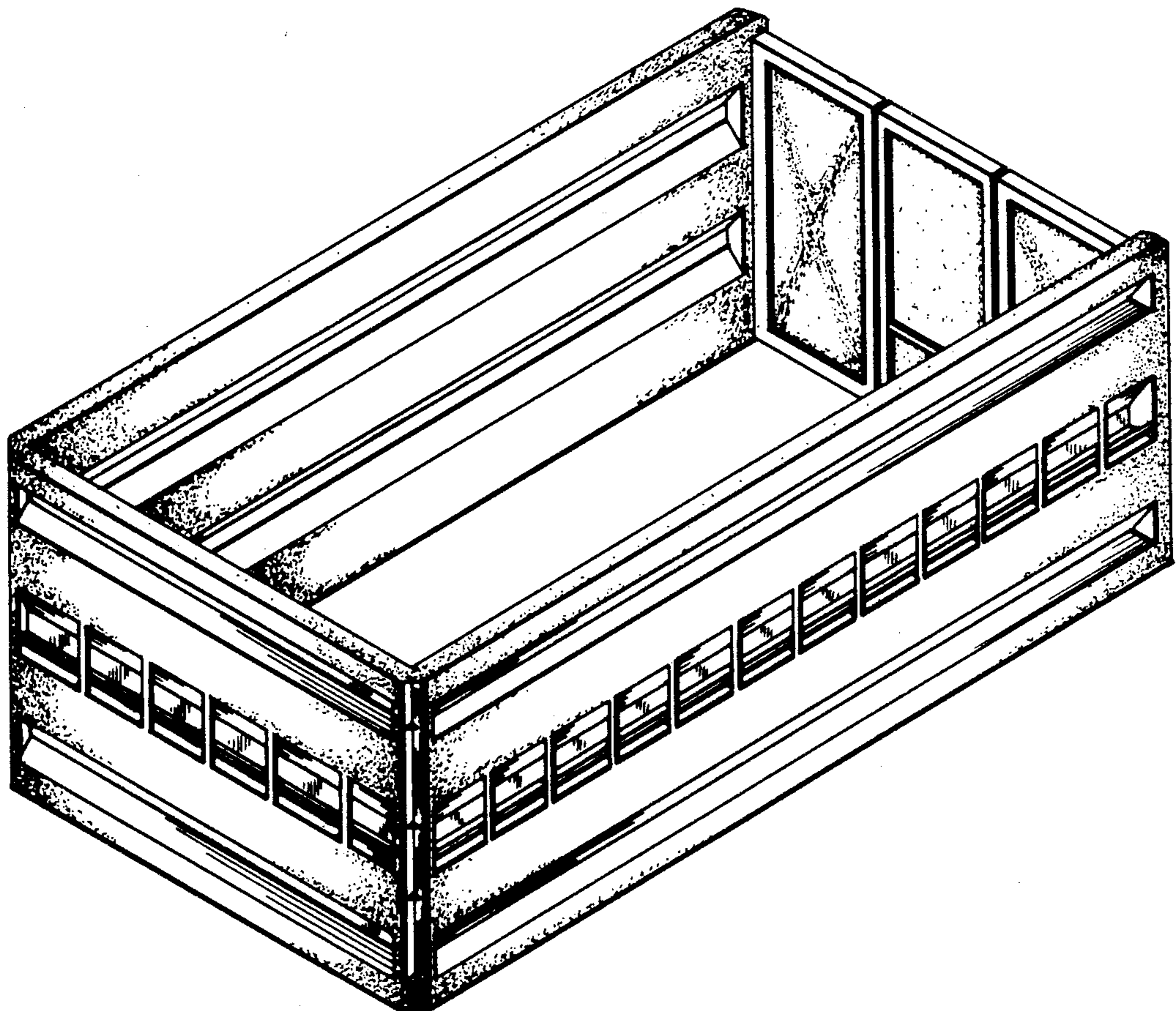

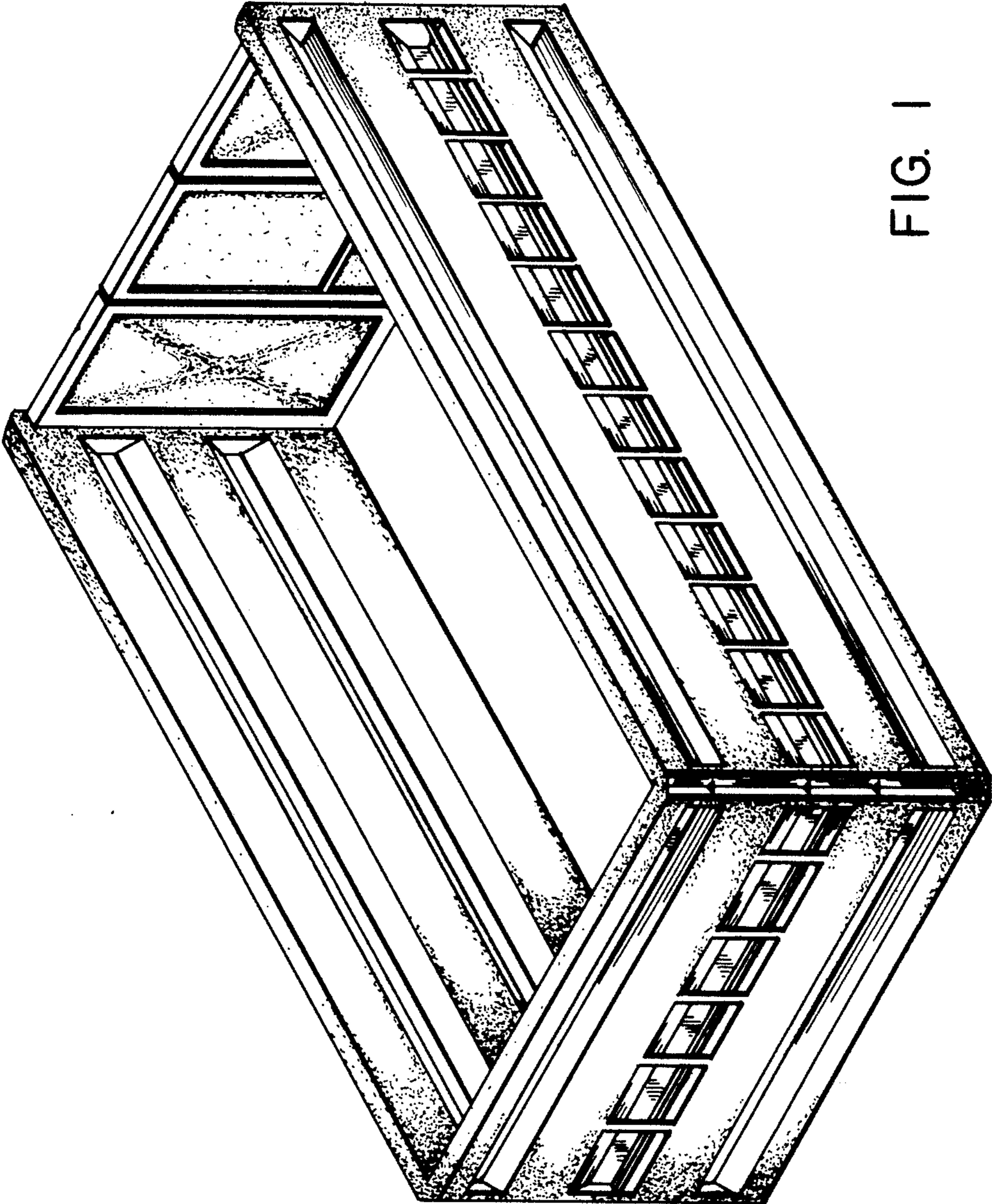

FIG. 1

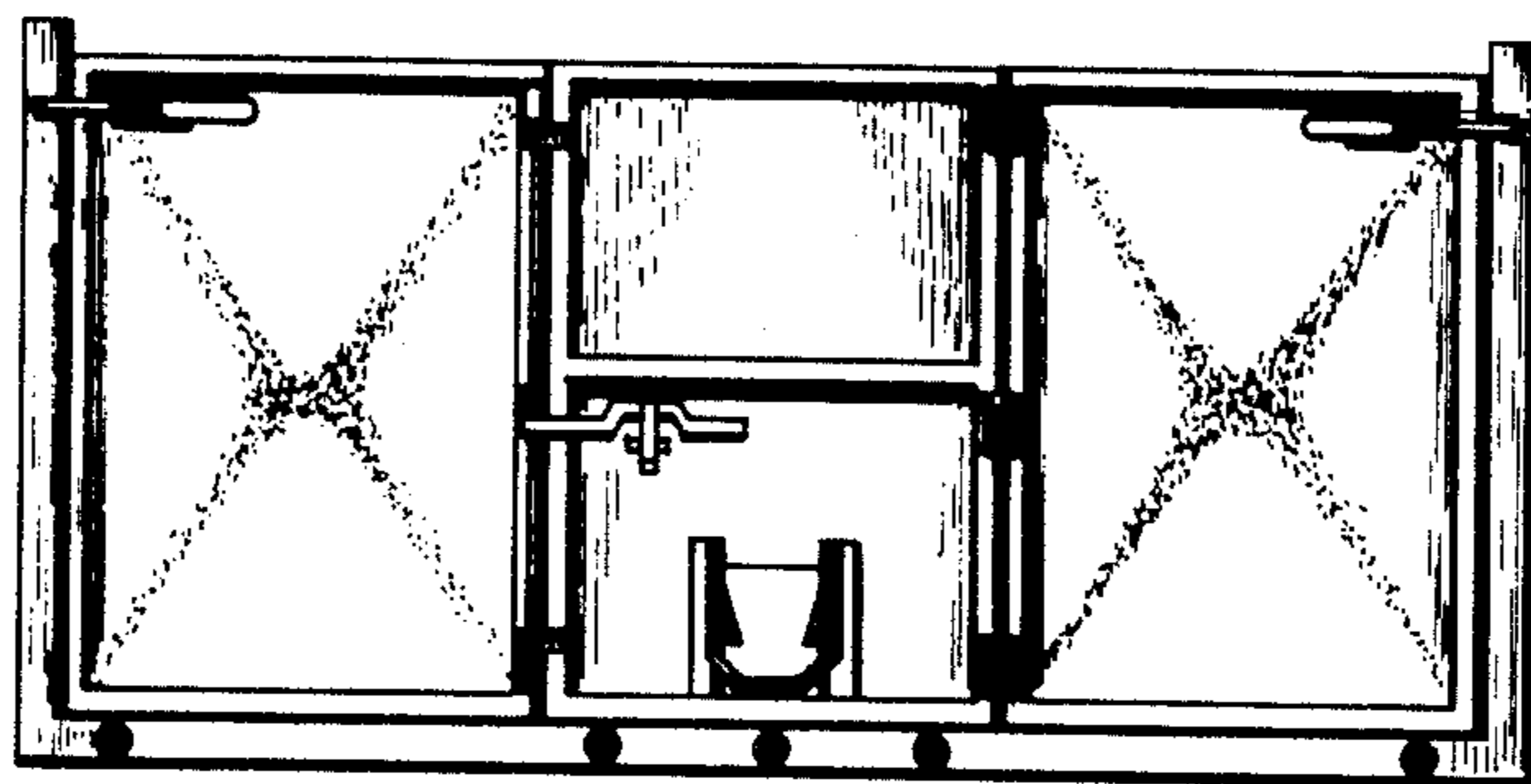

FIG. 2

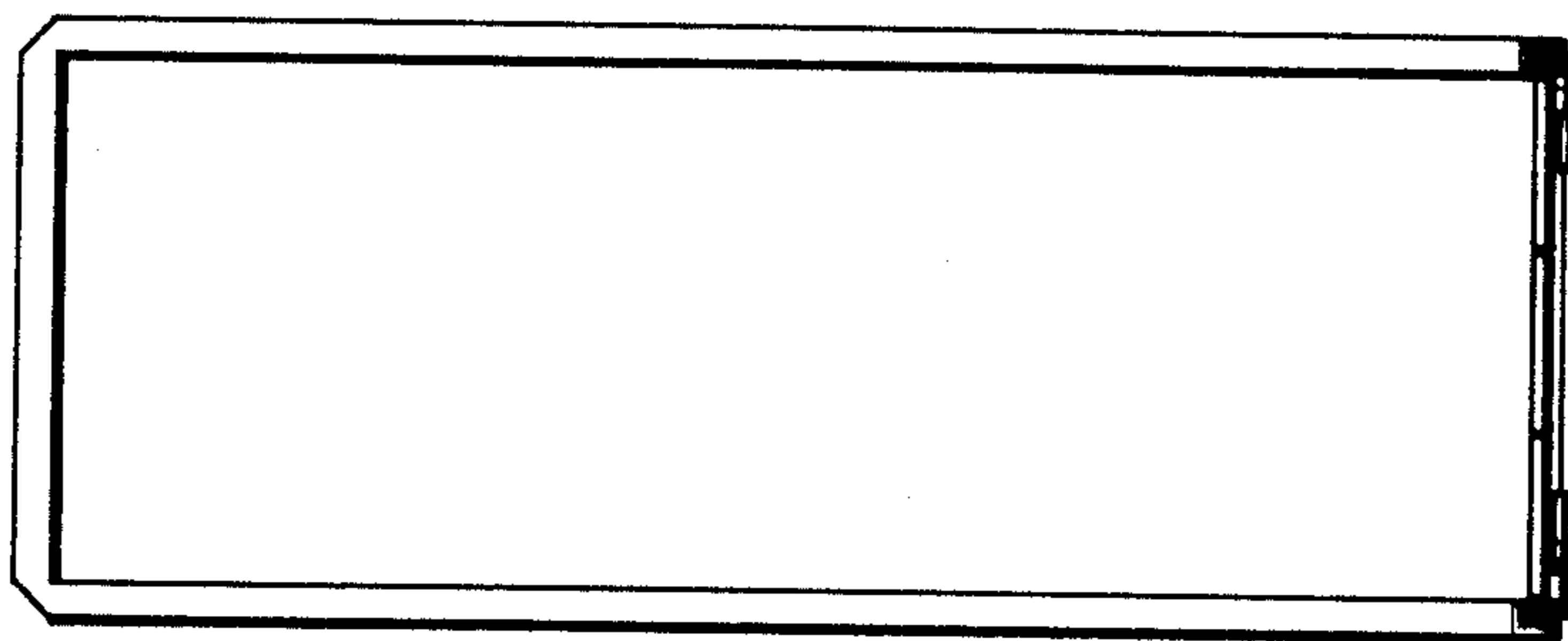

FIG. 3

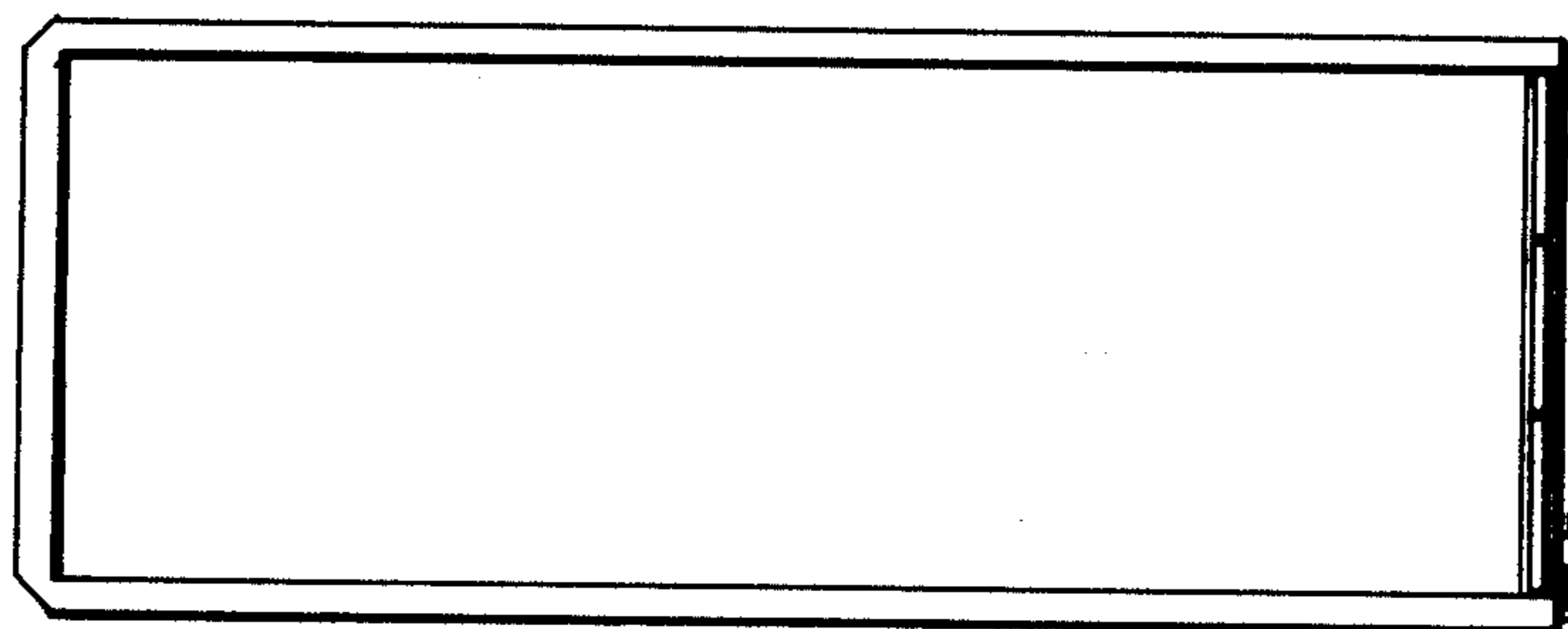

FIG. 4

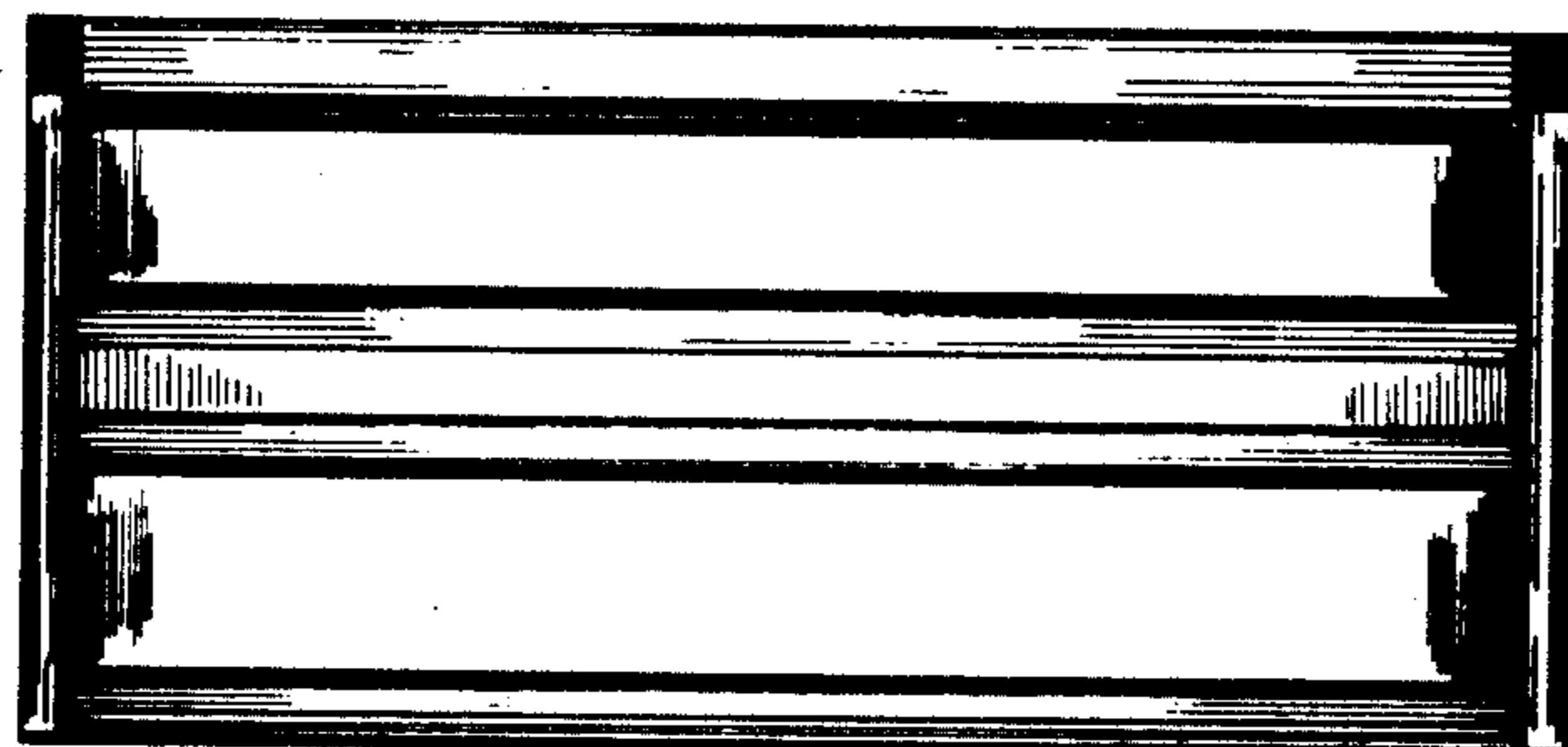

FIG. 5