

[54] DWELL/TACHOMETER

[75] Inventors: David E. Maxwell, Cary; James R. Shaffer, Mt. Prospect; Lee Radtke, Lake Zurich, all of Ill.

[73] Assignee: Sun Electric Corporation

[**] Term: 14 Years

[21] Appl. No.: 744,699

[22] Filed: Nov. 24, 1976

[51] Int. Cl. D10-04

[52] U.S. Cl. D10/75; D10/46; D10/78

[58] Field of Search D10/46, 75-78, D10/80; D13/40, 41; 324/16 T, 156

[56] References Cited

U.S. PATENT DOCUMENTS

D. 180,280 5/1957 Hartz D10/78

D. 205,906	10/1966	Stevenson	D10/78 X
D. 218,117	7/1970	Sato	D10/78 X
D. 235,742	7/1975	Rock	D10/46
D. 246,767	12/1977	Needham	D10/78
D. 247,100	1/1978	Schwartz	D10/78

Primary Examiner—Nelson C. Holtje
Attorney, Agent, or Firm—George B. Newitt

[57] CLAIM

The ornamental design for a dwell/tachometer, as shown and described.

DESCRIPTION

FIG. 1 is a top, right, front perspective view of a dwell-tachometer showing our new design;
FIG. 2 is a front elevational view thereof;
FIG. 3 is a top plan view thereof;
FIG. 4 is a right side elevational view thereof;
FIG. 5 is a top, left rear perspective view thereof;
FIG. 6 is a rear elevational view thereof;
FIG. 7 is a bottom plan view thereof.

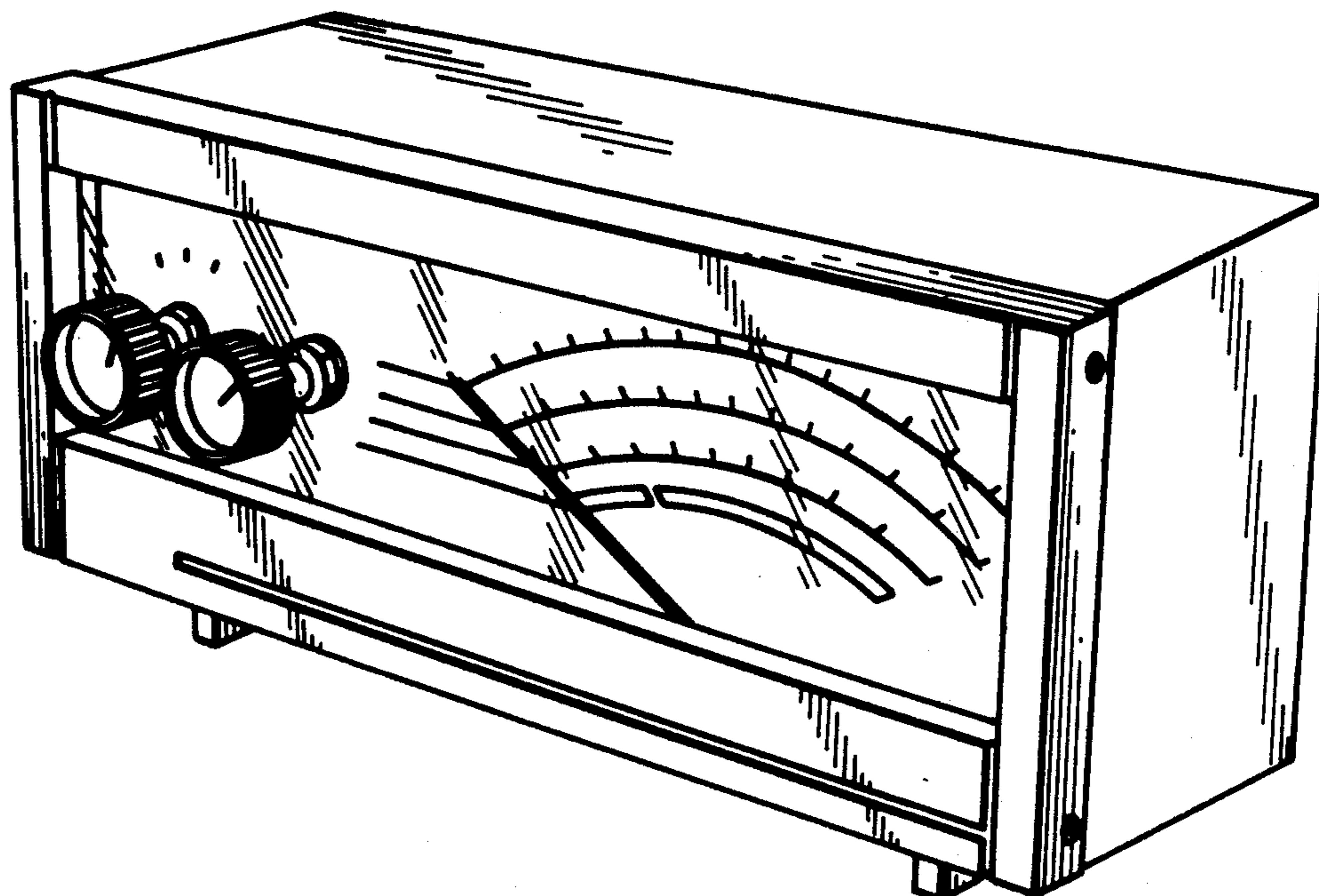

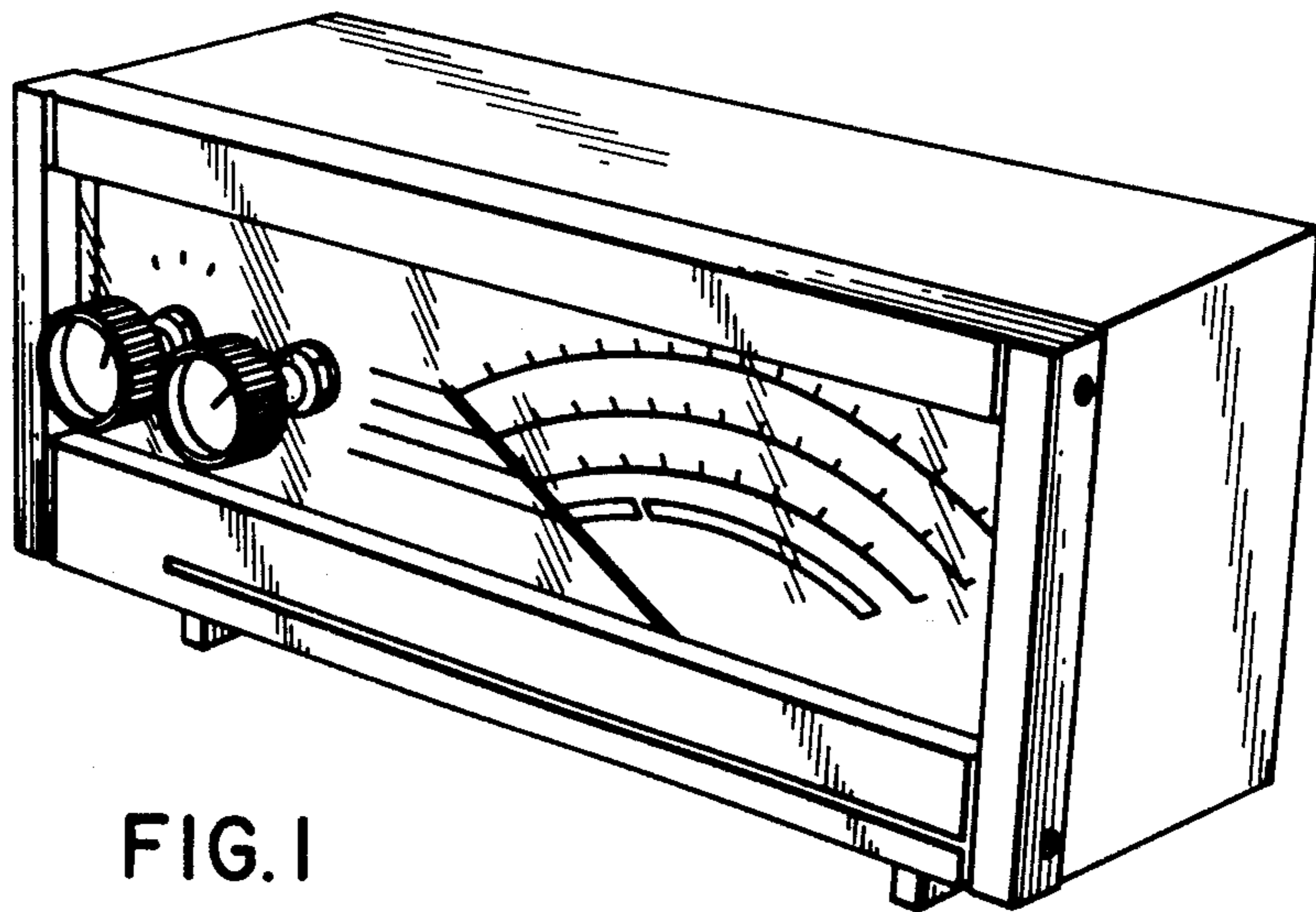

FIG. 1

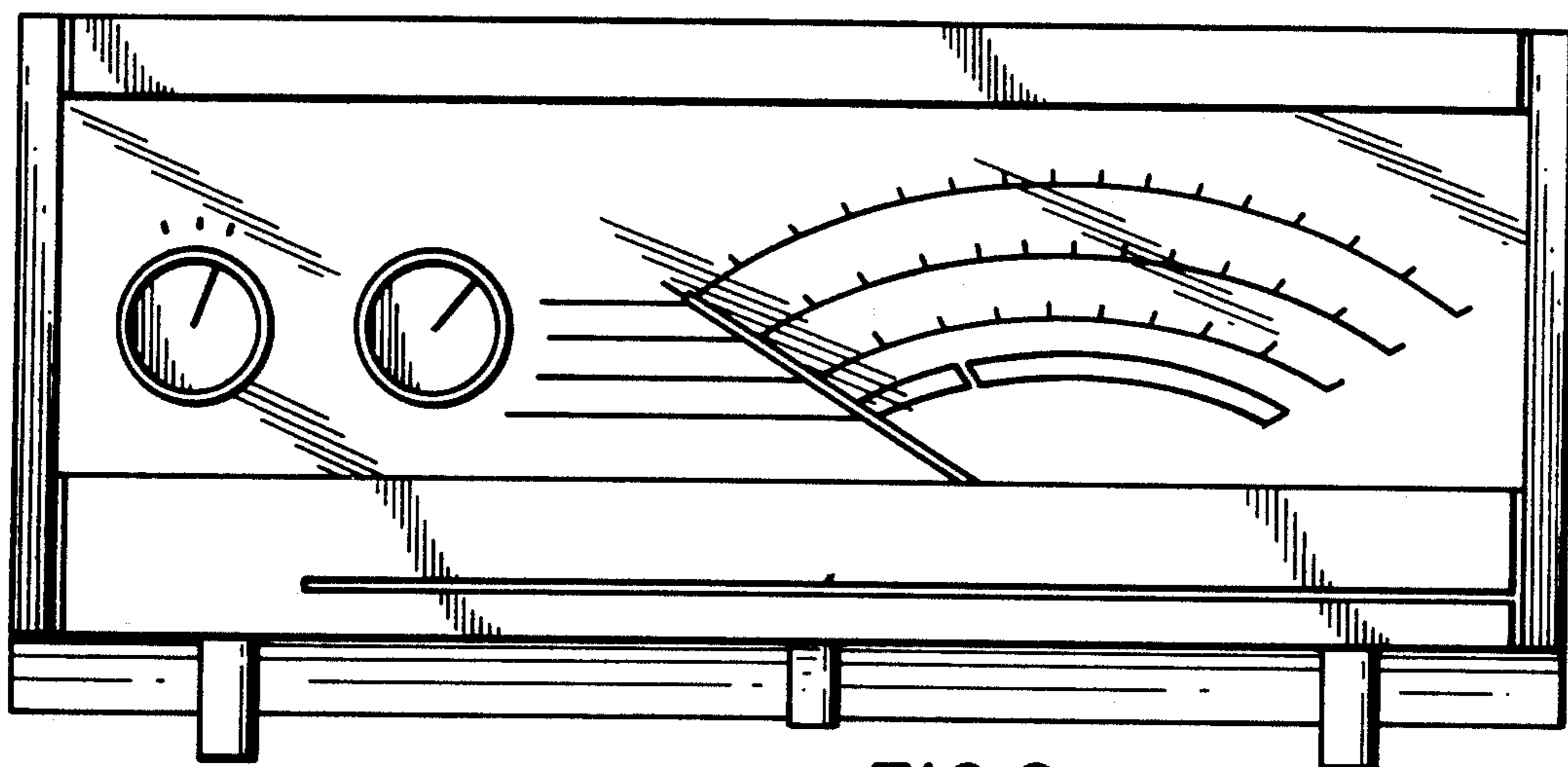

FIG. 2

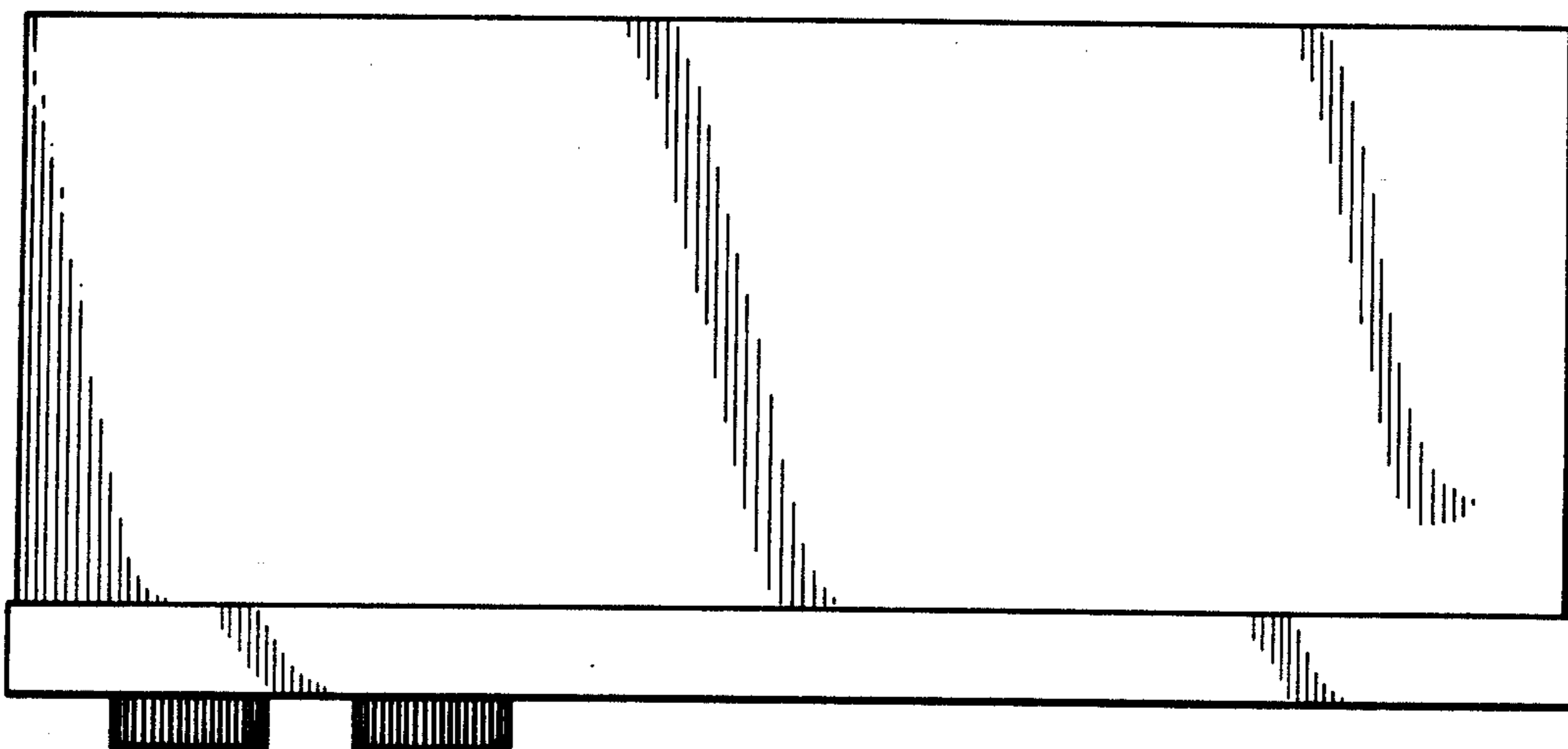

FIG. 3

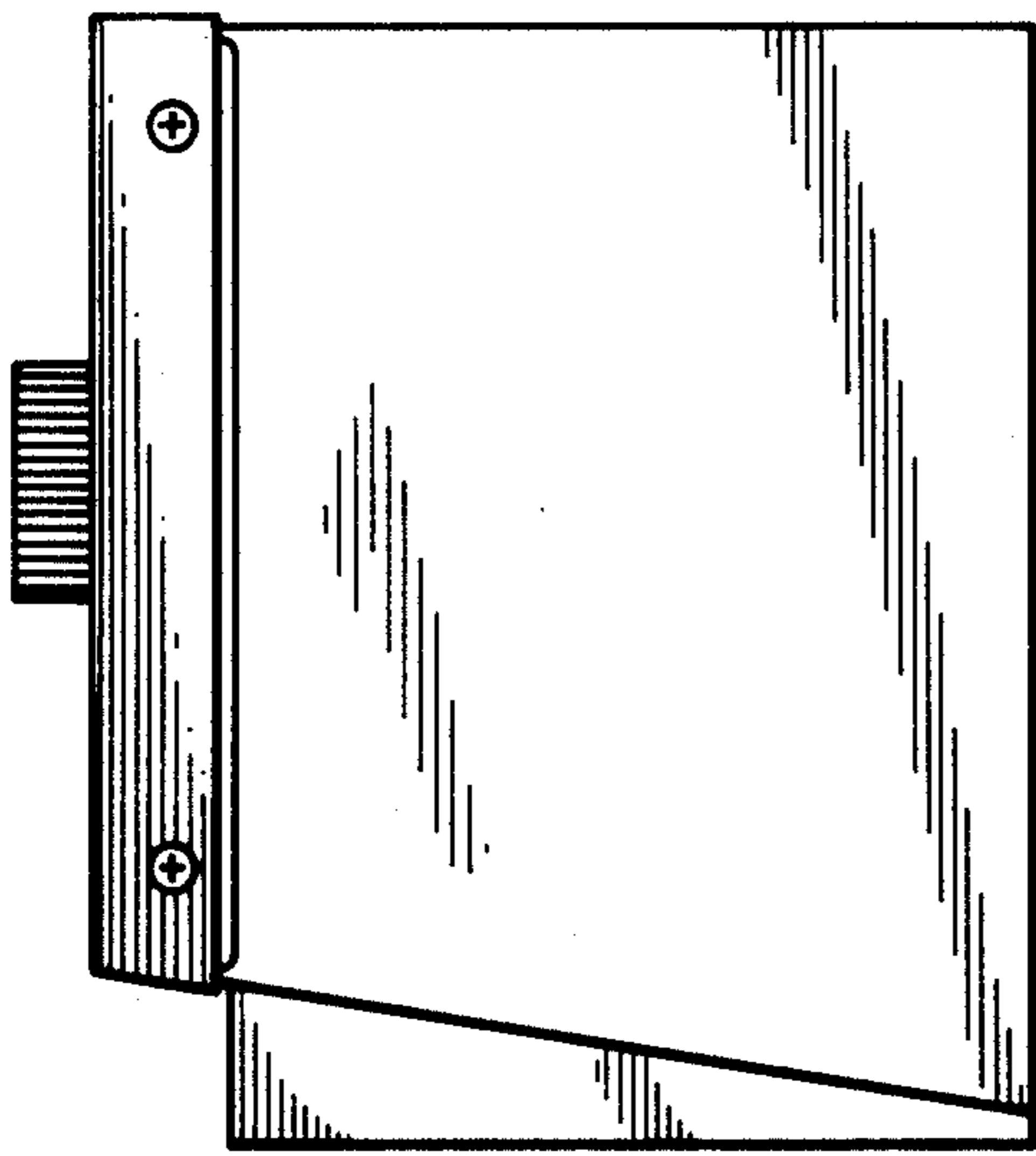

FIG. 4

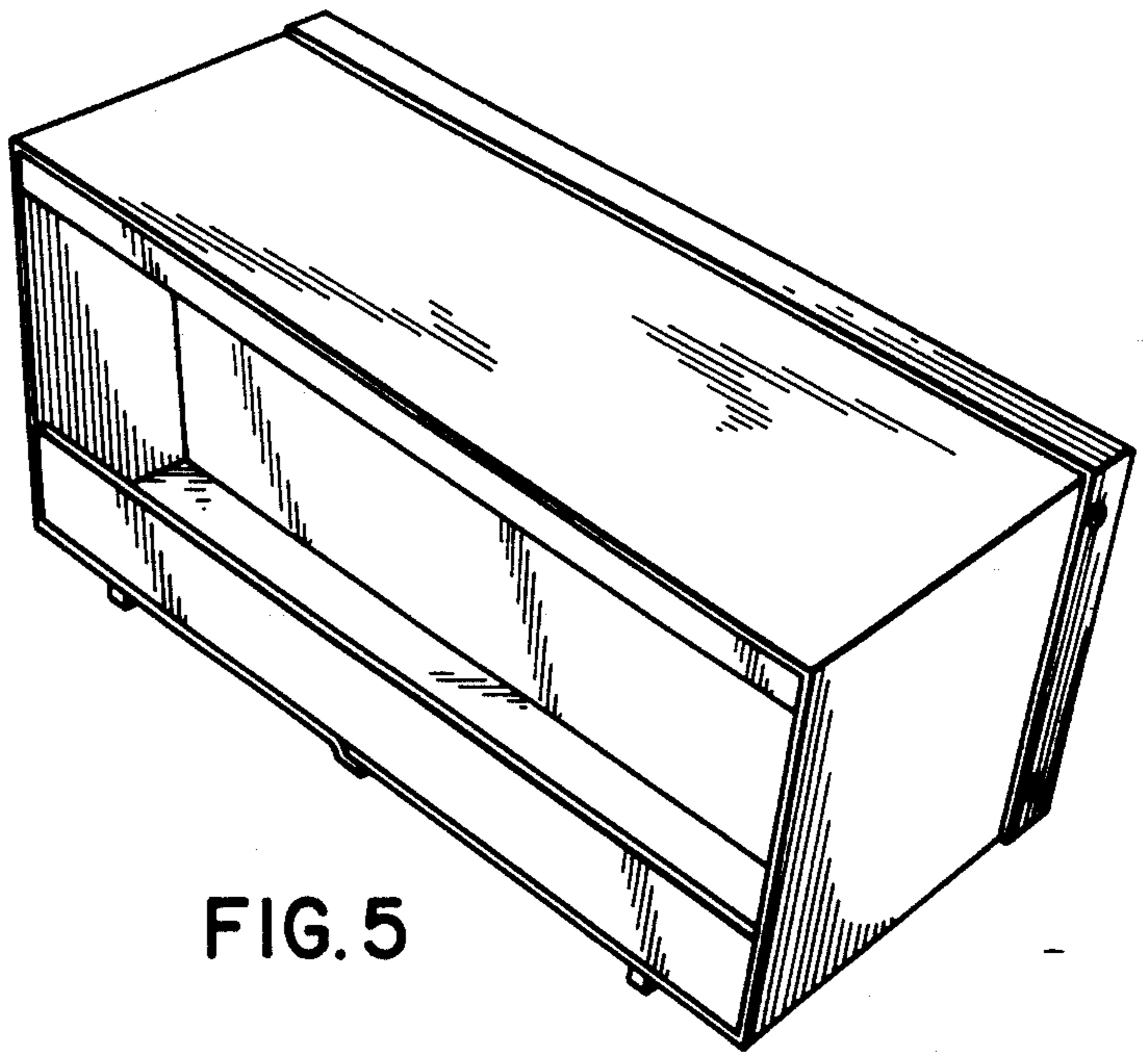

FIG. 5

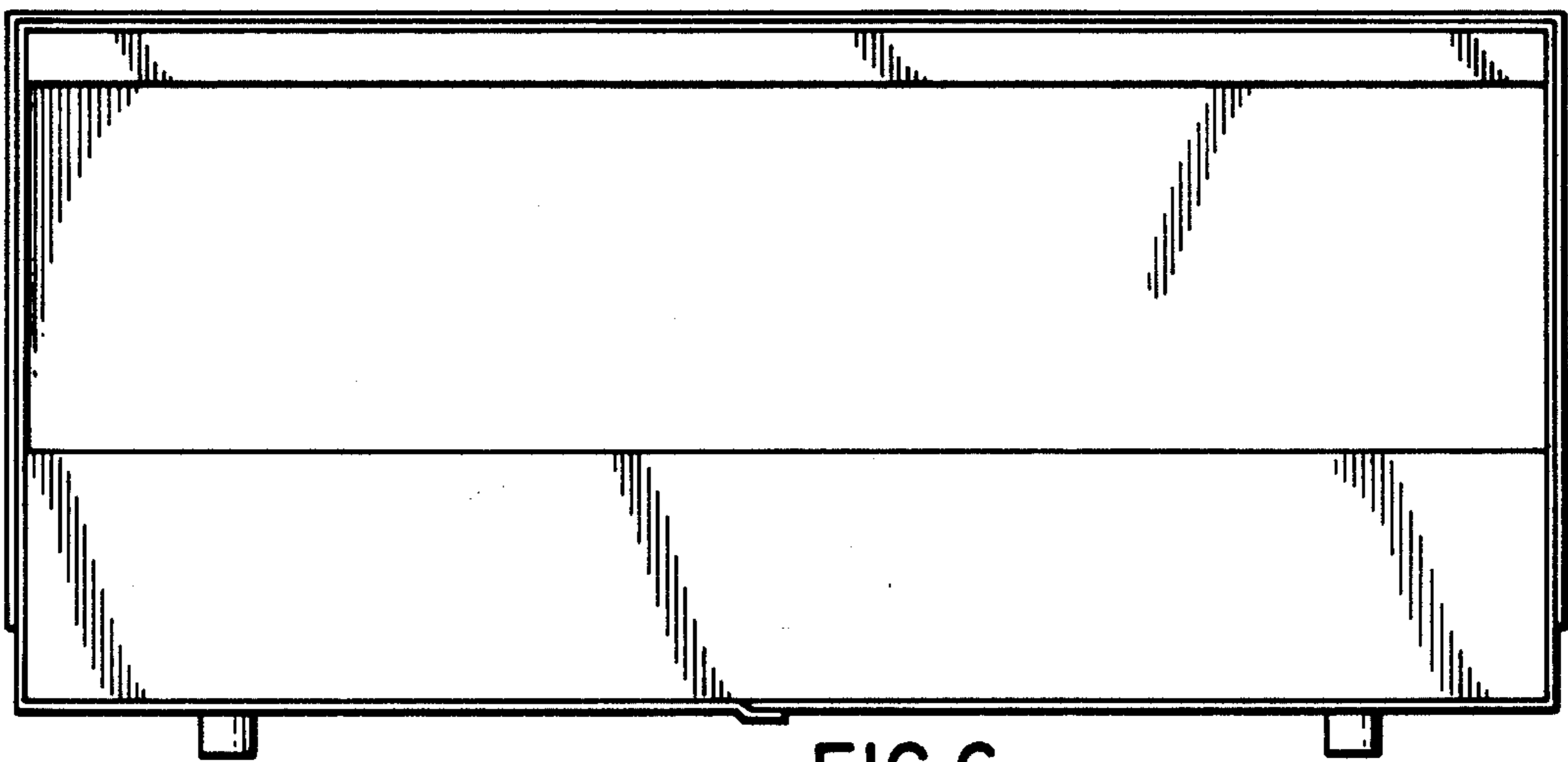

FIG. 6

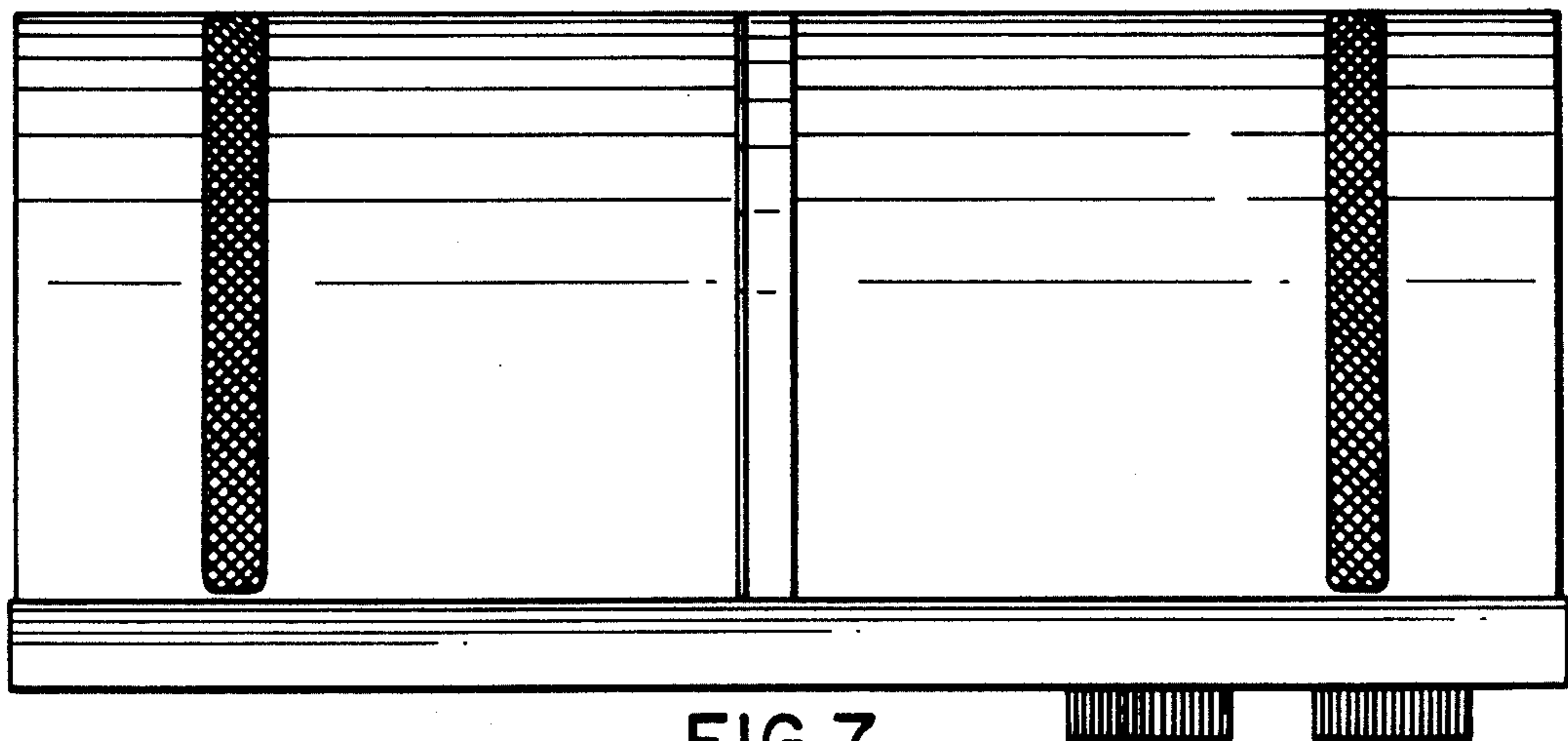

FIG. 7