

[54] **BABY BOTTLE HOLDER**

[76] Inventor: **Edward Sussman**, 166-25 Powells Cove Blvd., Beechhurst, Queens, N.Y. 11427

[**] Term: **14 Years**

[21] Appl. No.: **761,439**

[22] Filed: **Jan. 21, 1977**

[51] Int. Cl. **D24-04**

[52] U.S. Cl. **D24/48**

[58] Field of Search 248/102, 105, 106, 206 R; D24/48; D8/396, 71

[56] **References Cited**

U.S. PATENT DOCUMENTS

D. 234,980 4/1975 Tomlin et al. D8/396 X
1,729,531 9/1929 Wolever 248/105

2,386,042 10/1945 Elzer 248/106
3,222,020 12/1965 Rea 248/106
4,001,444 1/1977 Clarke 211/74

Primary Examiner—Bernard Ansher
Attorney, Agent, or Firm—George Gottlieb

[57] **CLAIM**

The ornamental design for a baby bottle holder, as shown and described.

DESCRIPTION

FIG. 1 is a top plan view of a baby bottle holder showing my new design;
FIG. 2 is a side elevation thereof;
FIG. 3 is a front elevation thereof;
FIG. 4 is a rear elevation thereof; and
FIG. 5 is a bottom plan view thereof.
The broken lines representing the baby bottle in FIG. 2 are shown for illustrative purposes only.

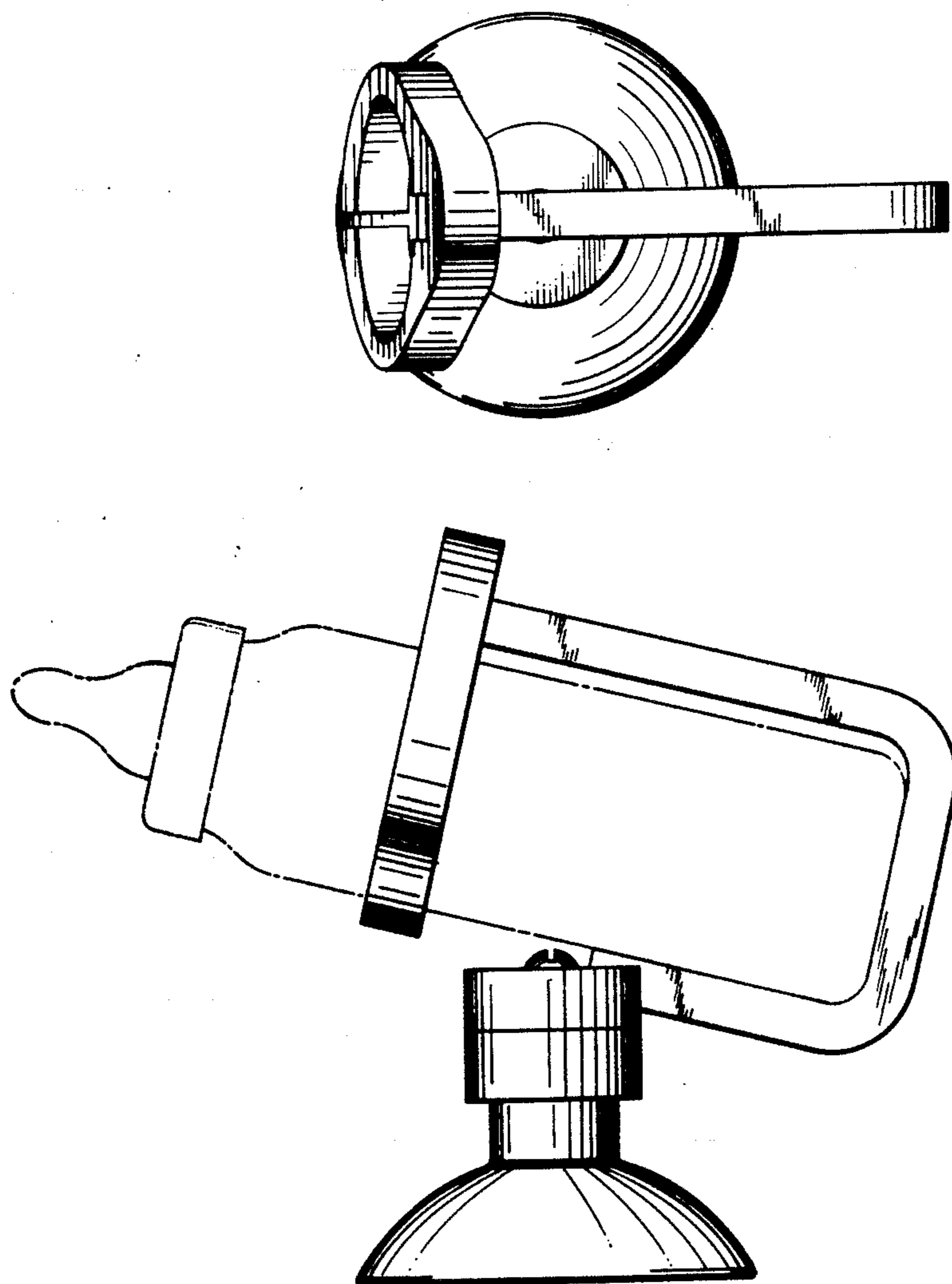

FIG. 1

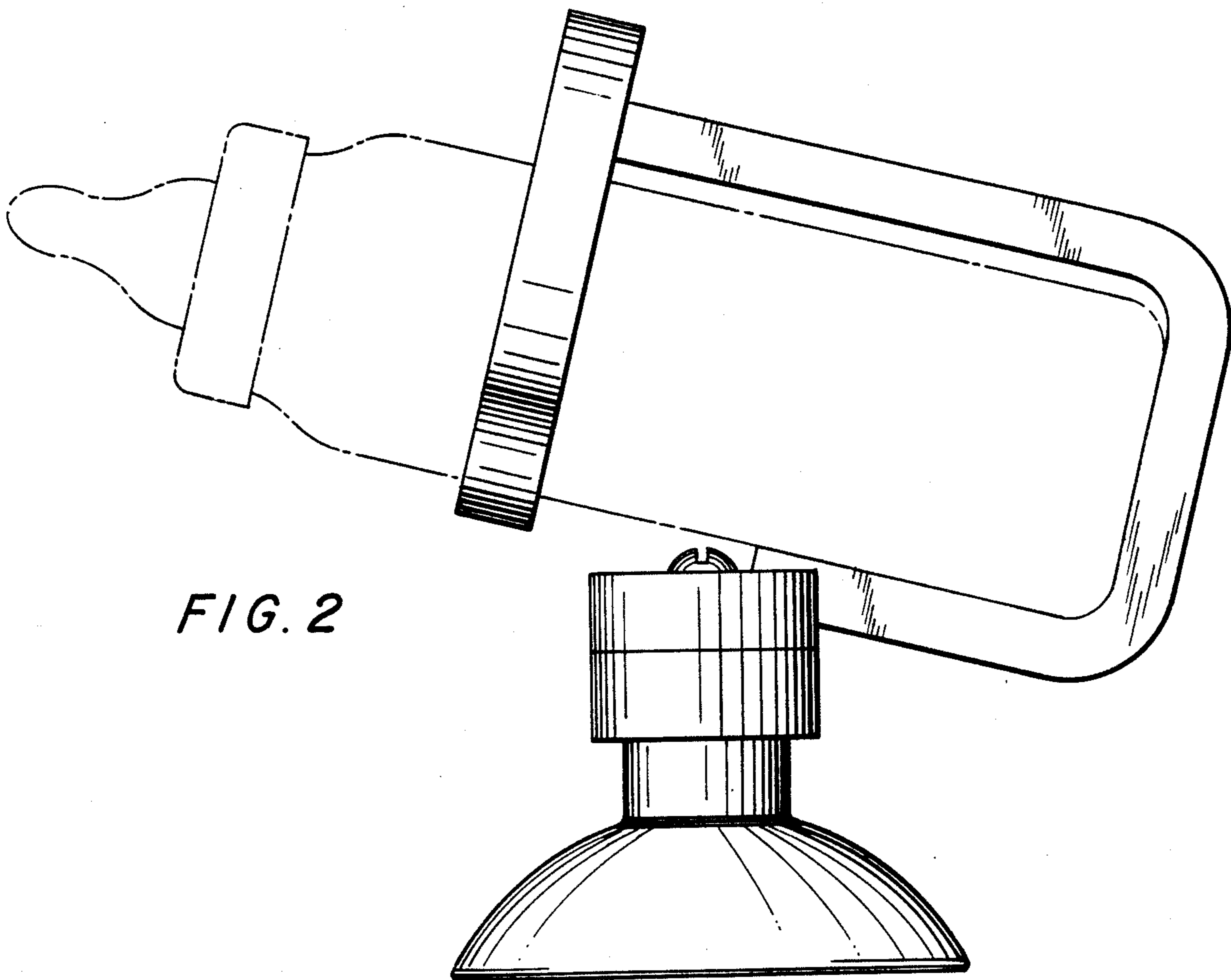
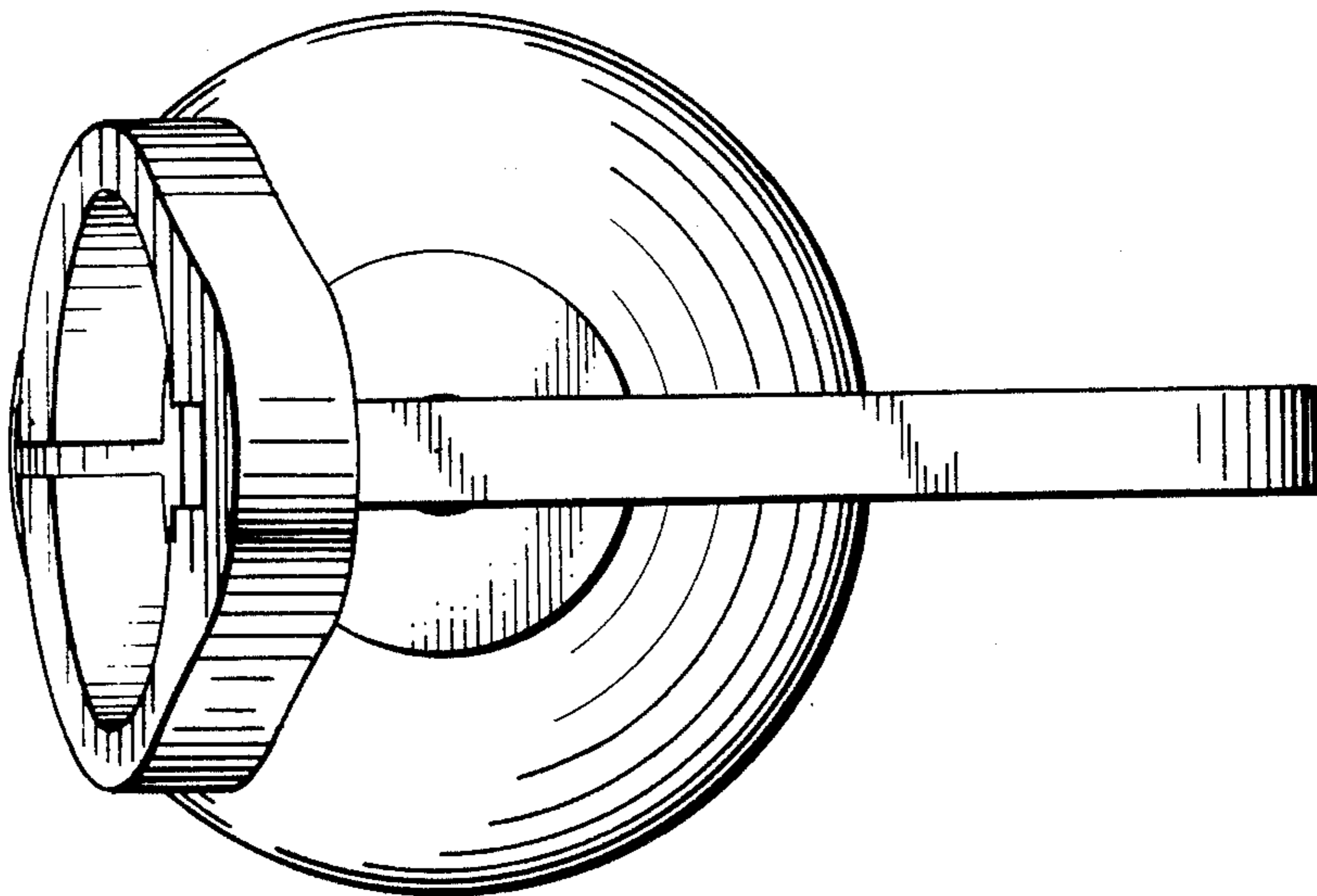

FIG. 2

FIG. 3

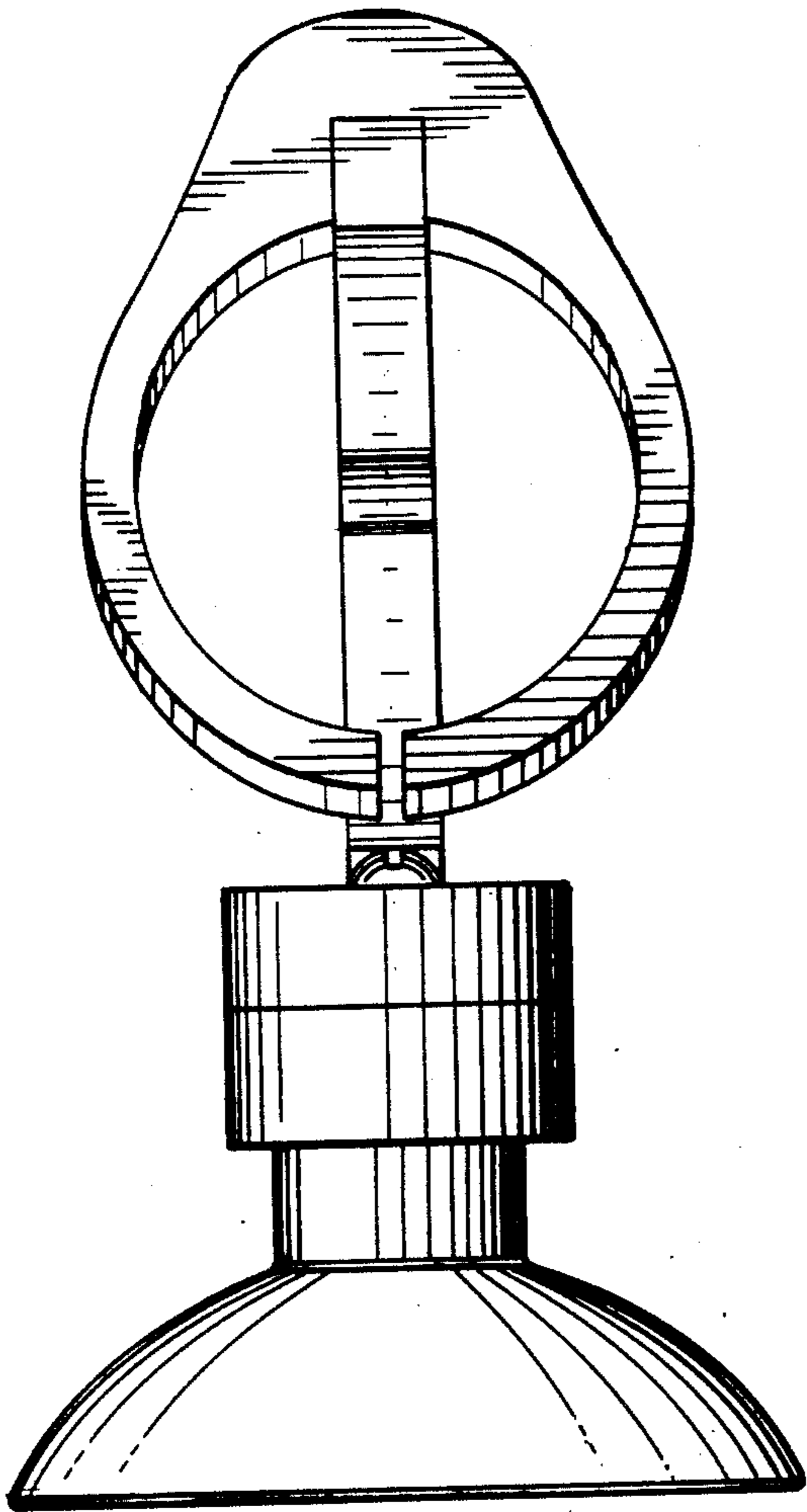

FIG. 4

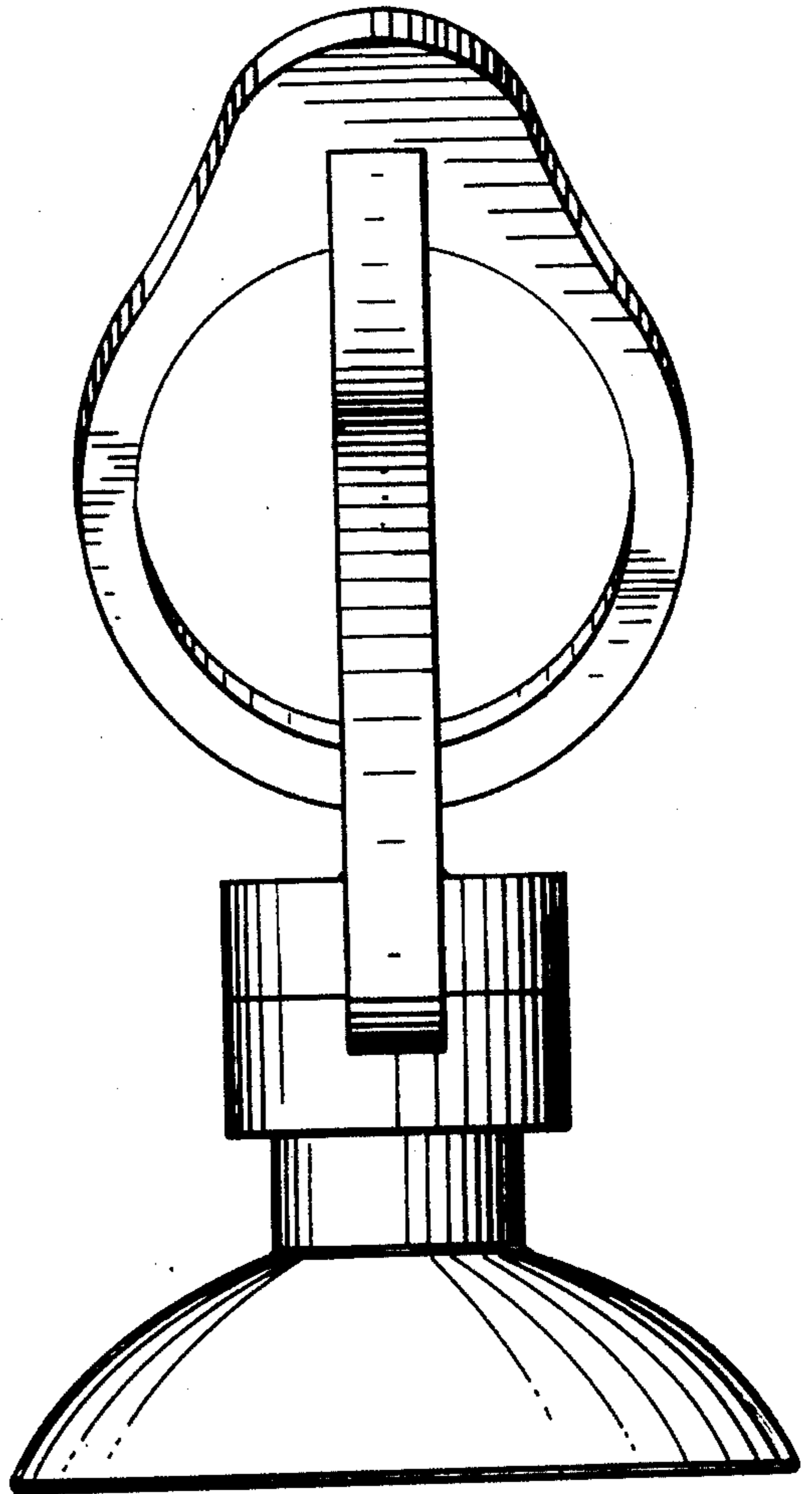

FIG. 5

