

[54] MUSIC INSTRUMENT CASE

[76] Inventor: Carlos Fernandez, 943 W. 34th St., Chicago, Ill.

[**] Term: 14 Years

[21] Appl. No.: 645,317

[22] Filed: Dec. 30, 1975

[51] Int. Cl. D3—02

[52] U.S. Cl. D56/1 B; D87/1 R

[58] Field of Search D56/1 B; D87/1 R, 3 F; 206/314, 14; D9/193; 150/52 R; 190/60

[56] References Cited

U.S. PATENT DOCUMENTS

D. 162,402	3/1951	Gold	D9/193
3,324,997	6/1967	Bonanno	D9/193
3,637,070	1/1972	Friedman	190/60

Primary Examiner—Winifred E. Herrmann
Assistant Examiner—George P. Word
Attorney, Agent, or Firm—Max Dressler

[57] CLAIM

The ornamental design for a music instrument case, substantially as shown and described.

DESCRIPTION

FIG. 1 is a perspective view of a music instrument case showing my new design;

FIG. 2 is a rear perspective view thereof; and

FIG. 3 is an enlarged scale fragmentary cross-sectional view taken along lines 3—3 of FIG. 2.

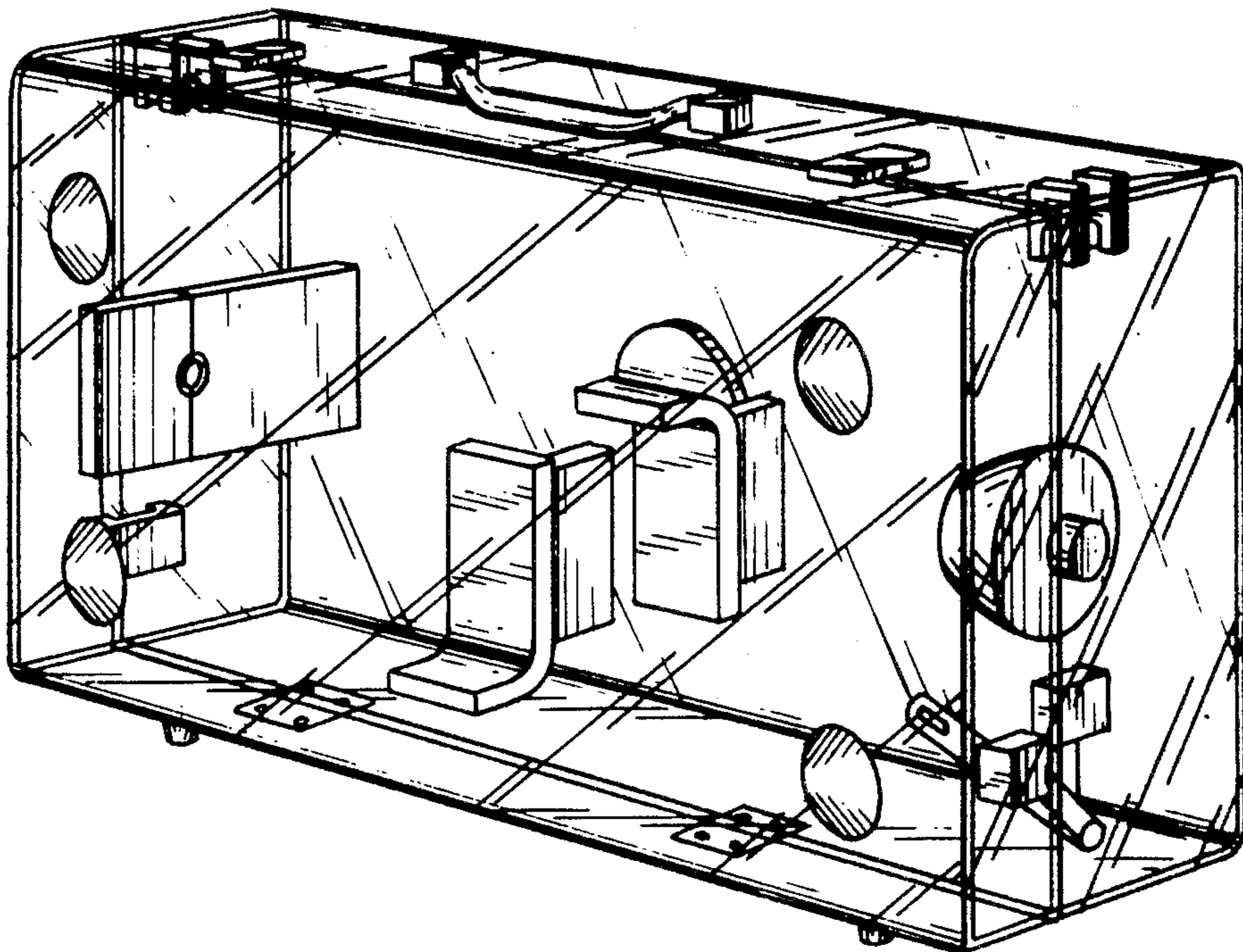

Fig. 1.

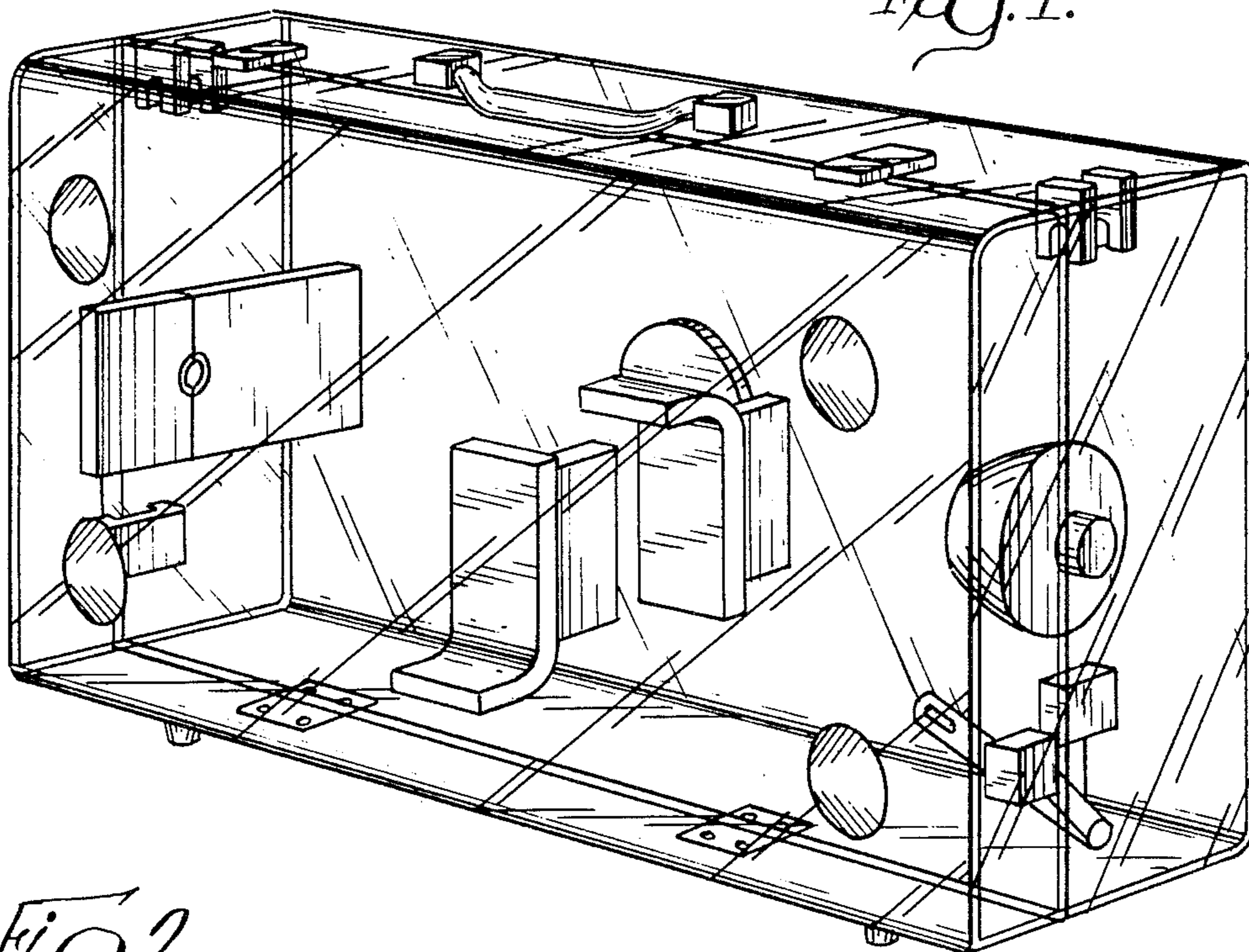

Fig. 2.

