

[54] CHAIR

[76] Inventor: Steven Douglas Gageby, 12 Hay Camp Rd., North Oaks, Minn. 55110

[**] Term: 14 Years

[21] Appl. No.: 677,601

[22] Filed: Apr. 16, 1976

[51] Int. Cl. D6-01

[52] U.S. Cl. D6/75; D6/78

[58] Field of Search D6/47, 37, 39, 67, 69, D6/70, 71, 72, 73, 75, 78

[56] References Cited

U.S. PATENT DOCUMENTS

D. 22,980	1/1974	Lindvall	D6/47
D. 37,508	8/1905	Stickley	D6/73
D. 58,960	9/1921	Wilcox	D6/75
D. 238,633	2/1976	Hunter	D6/78 X

OTHER PUBLICATIONS

Domus Catalog, Jul. 1970, p. 34, chair in panel 10, top center.

Interiors, Aug. 1973, p. 36, chair bottom right.

Primary Examiner—Bruce W. Dunkins

Attorney, Agent, or Firm—Steven Douglas Gageby

[57] CLAIM

The ornamental design for a chair, as shown and described.

DESCRIPTION

FIG. 1 is a front elevation view of a chair showing my new design, the recessed areas are shaded for color contrast;

FIG. 2 is a side elevation view thereof, the undisclosed side being substantially identical to the side shown, the recessed area is shaded for color contrast;

FIG. 3 is a rear elevation view thereof, the recessed areas are shaded for color contrast;

FIG. 4 is a top view thereof, the recessed areas are shaded for color contrast;

FIG. 5 is a cross-section taken on line 5—5 of FIG. 1, the recessed areas are shaded for color contrast;

FIG. 6 is a cross-section taken on line 6—6 of FIG. 2, the recessed areas are shaded for color contrast;

FIG. 7 is a cross-section taken on line 7—7 of FIG. 3;

FIG. 8 is a second embodiment of FIG. 3;

FIG. 9 is a second embodiment of FIG. 2;

FIG. 10 is a third embodiment of FIG. 3;

FIG. 11 is a front perspective view of my new design, the recessed areas are shaded for color contrast; and

FIG. 12 is a rear perspective view thereof, the recessed areas are shaded for color contrast.

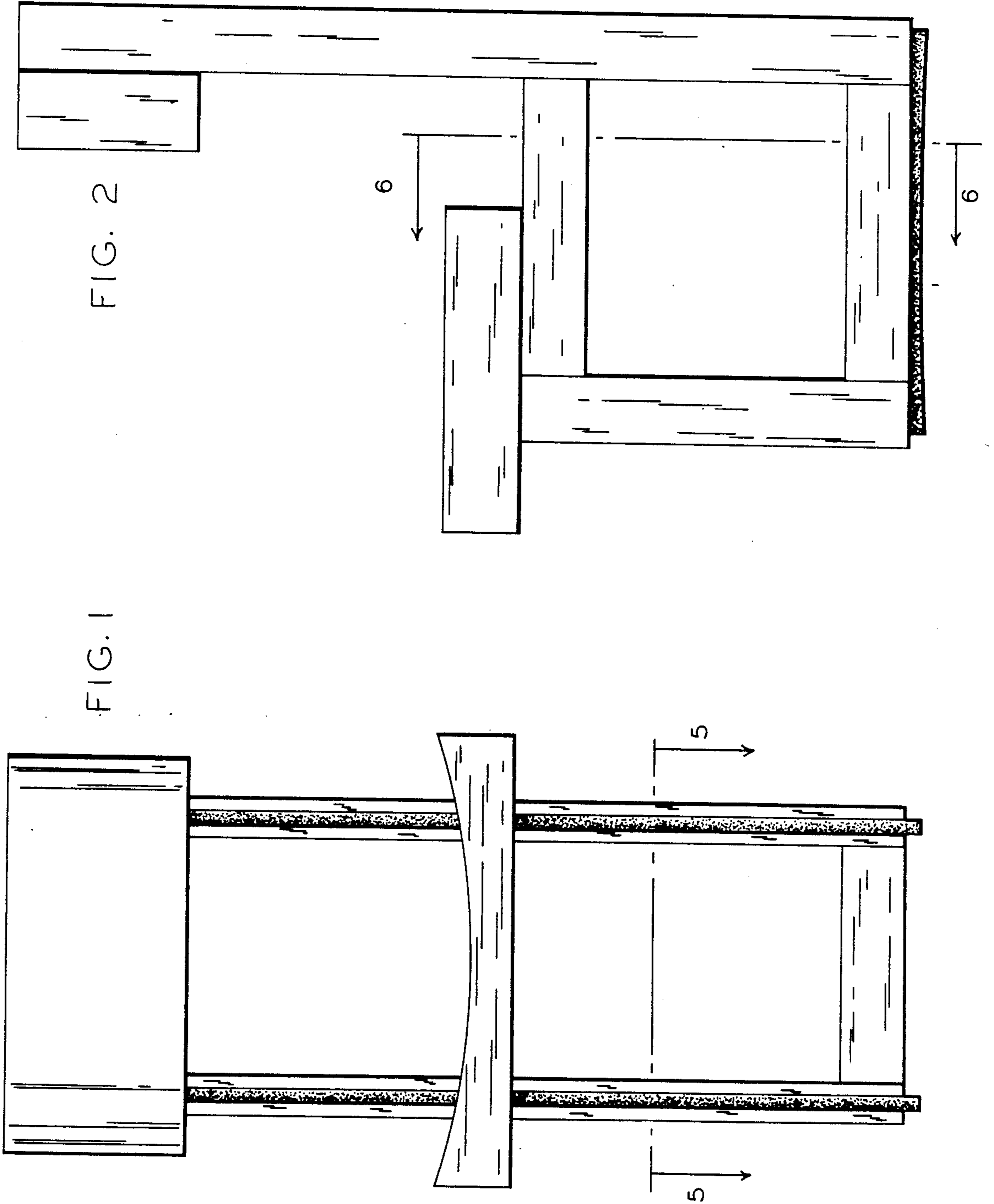

FIG. 2

FIG. 1

FIG. 6

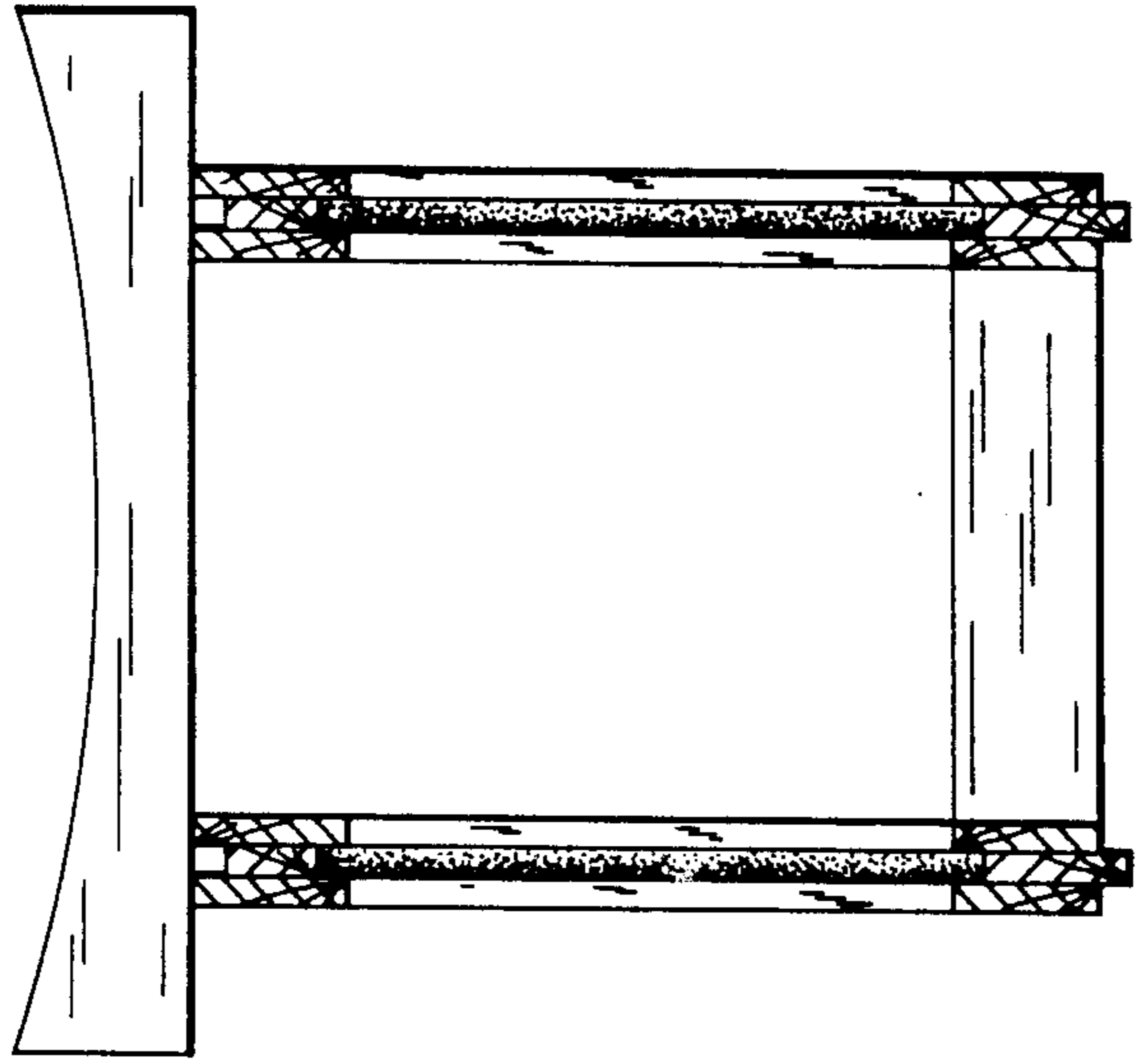

FIG. 7

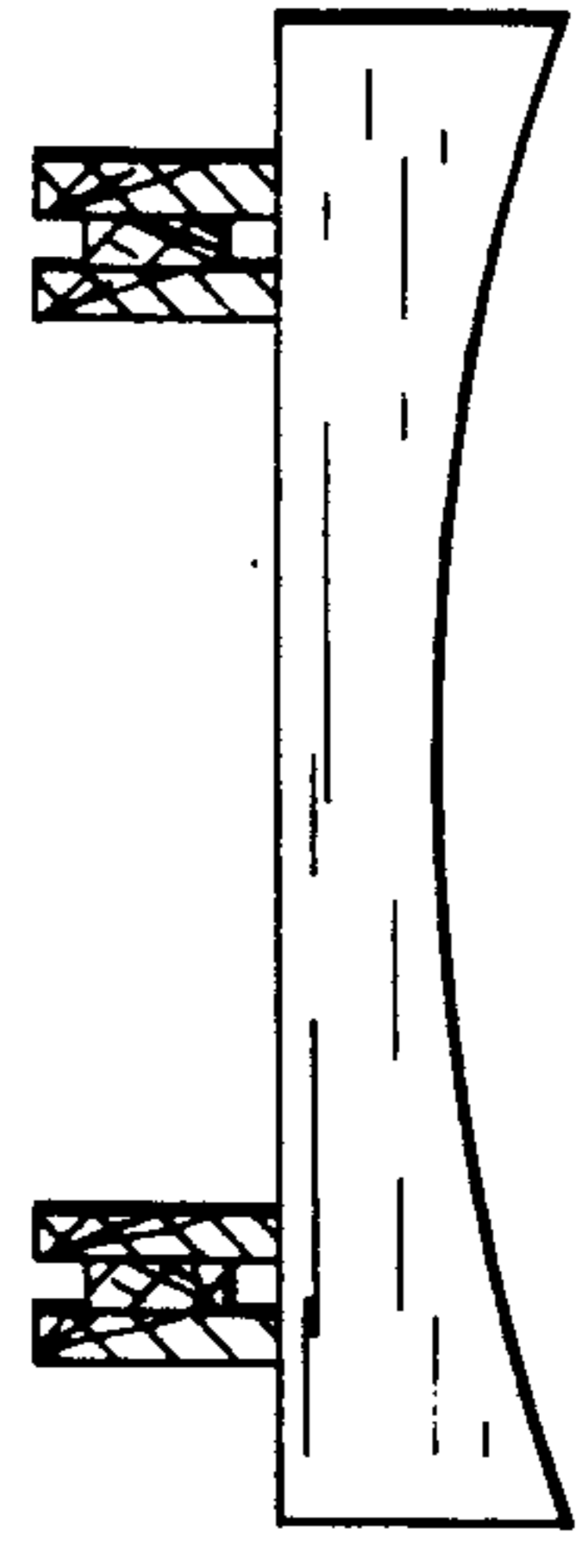

FIG. 4

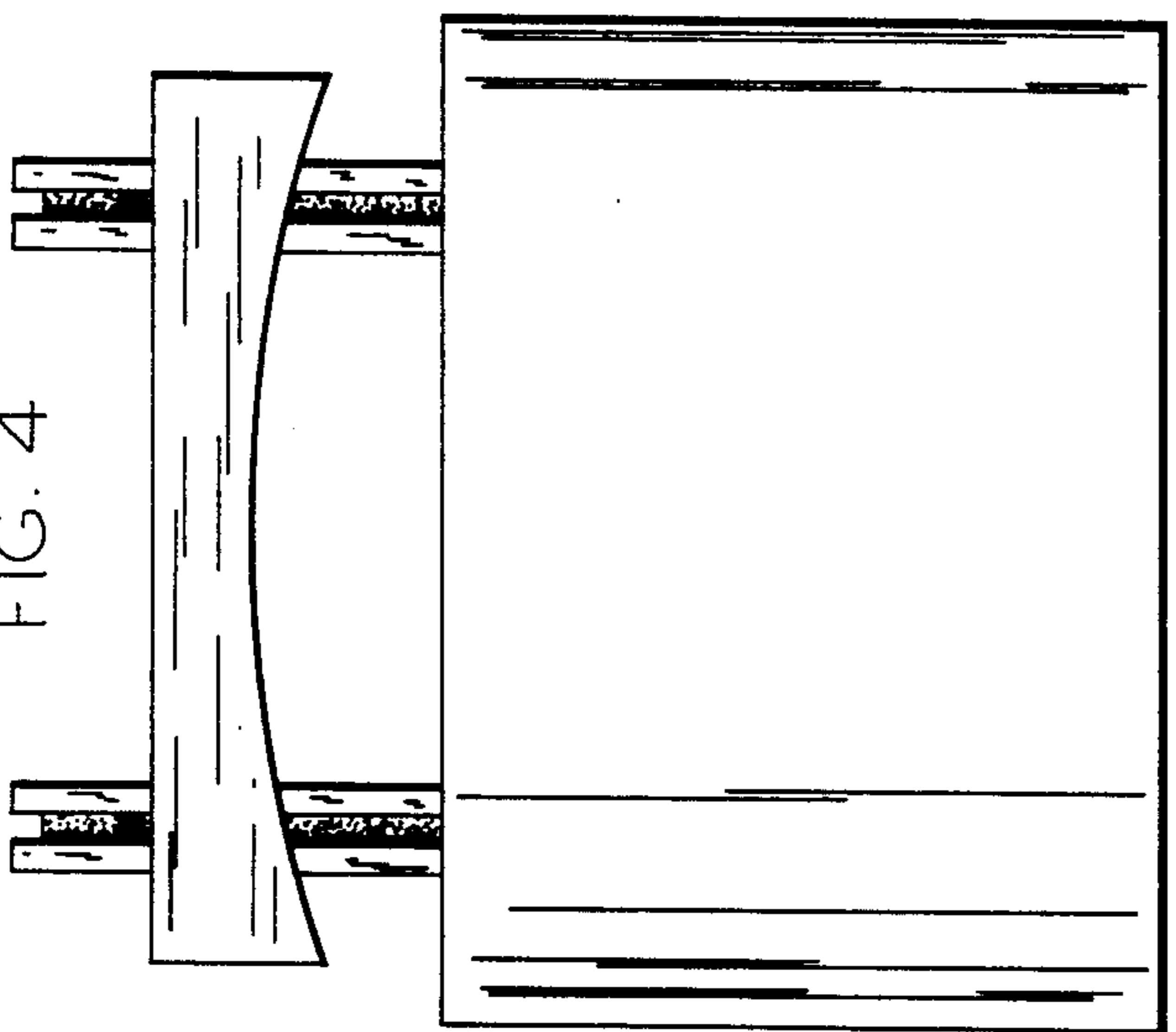

FIG. 5

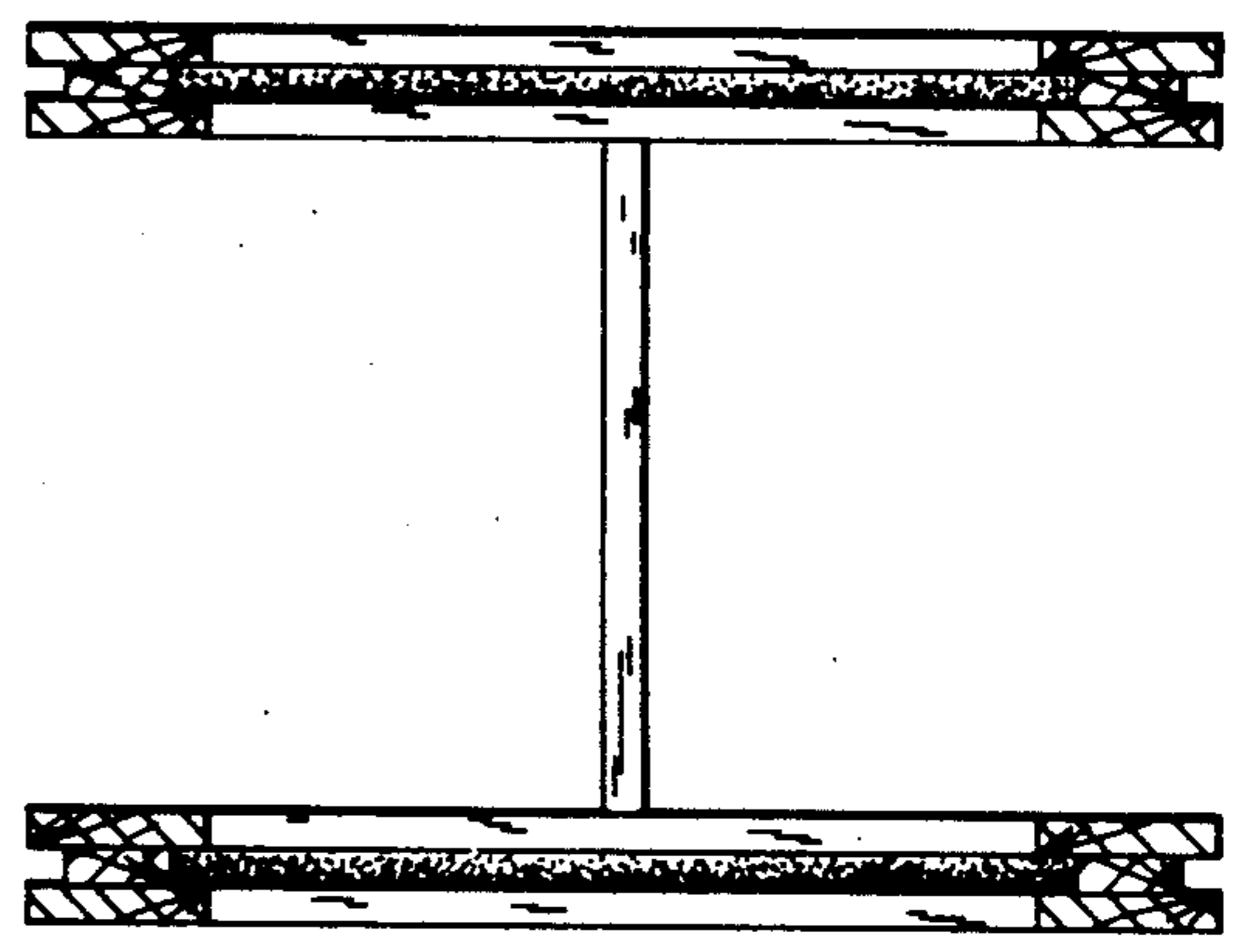
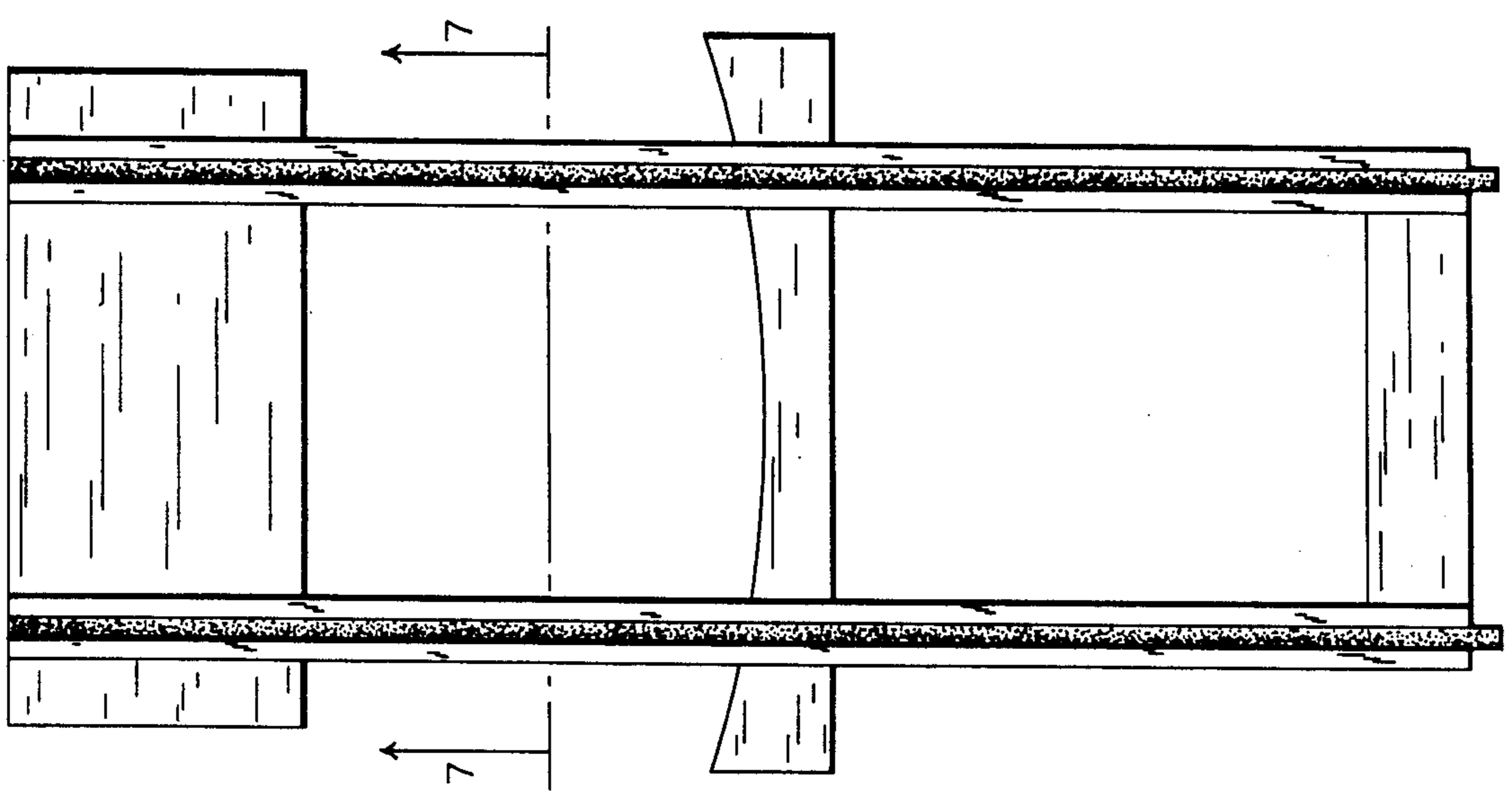

FIG. 3



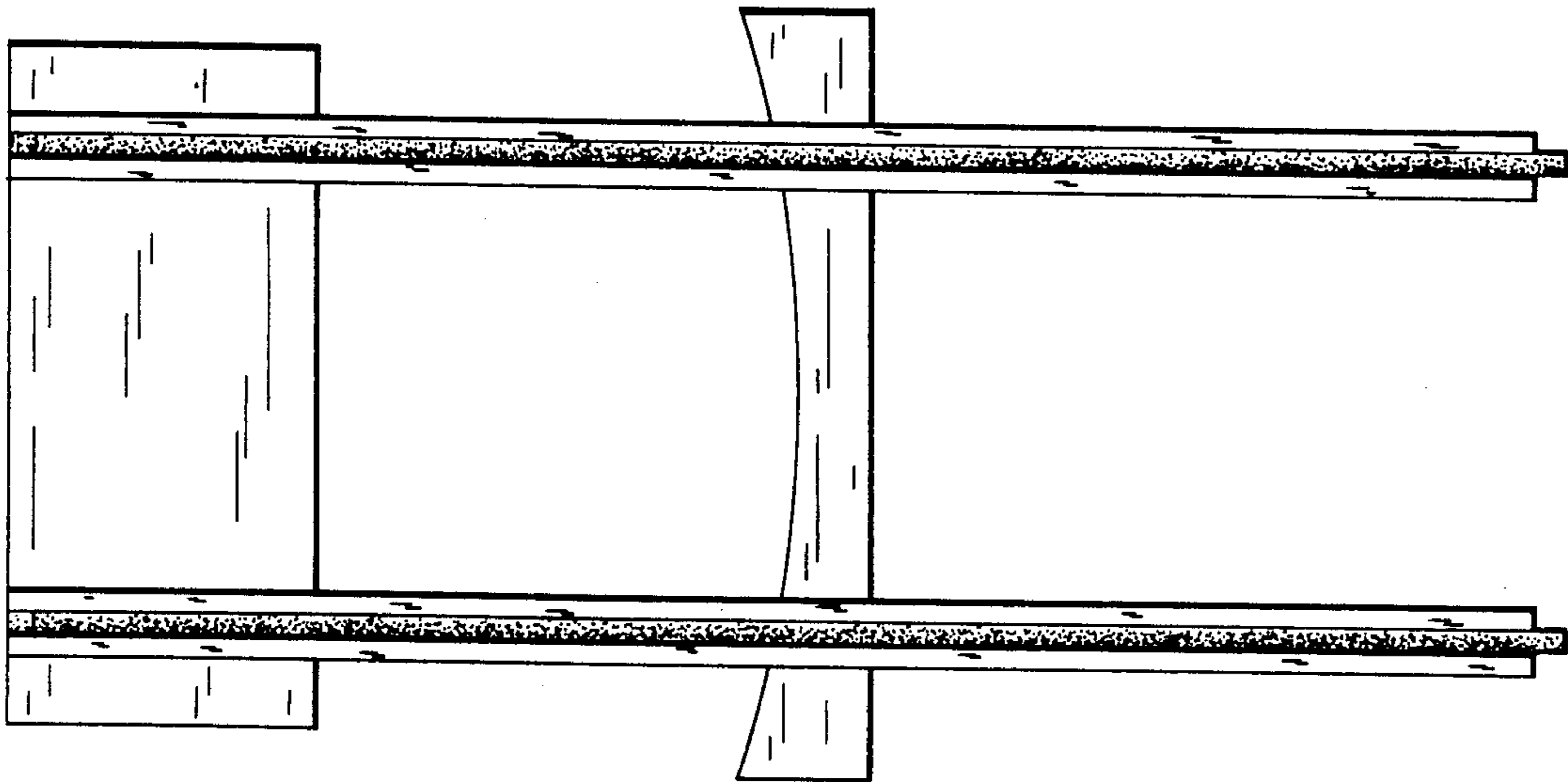

FIG. 8

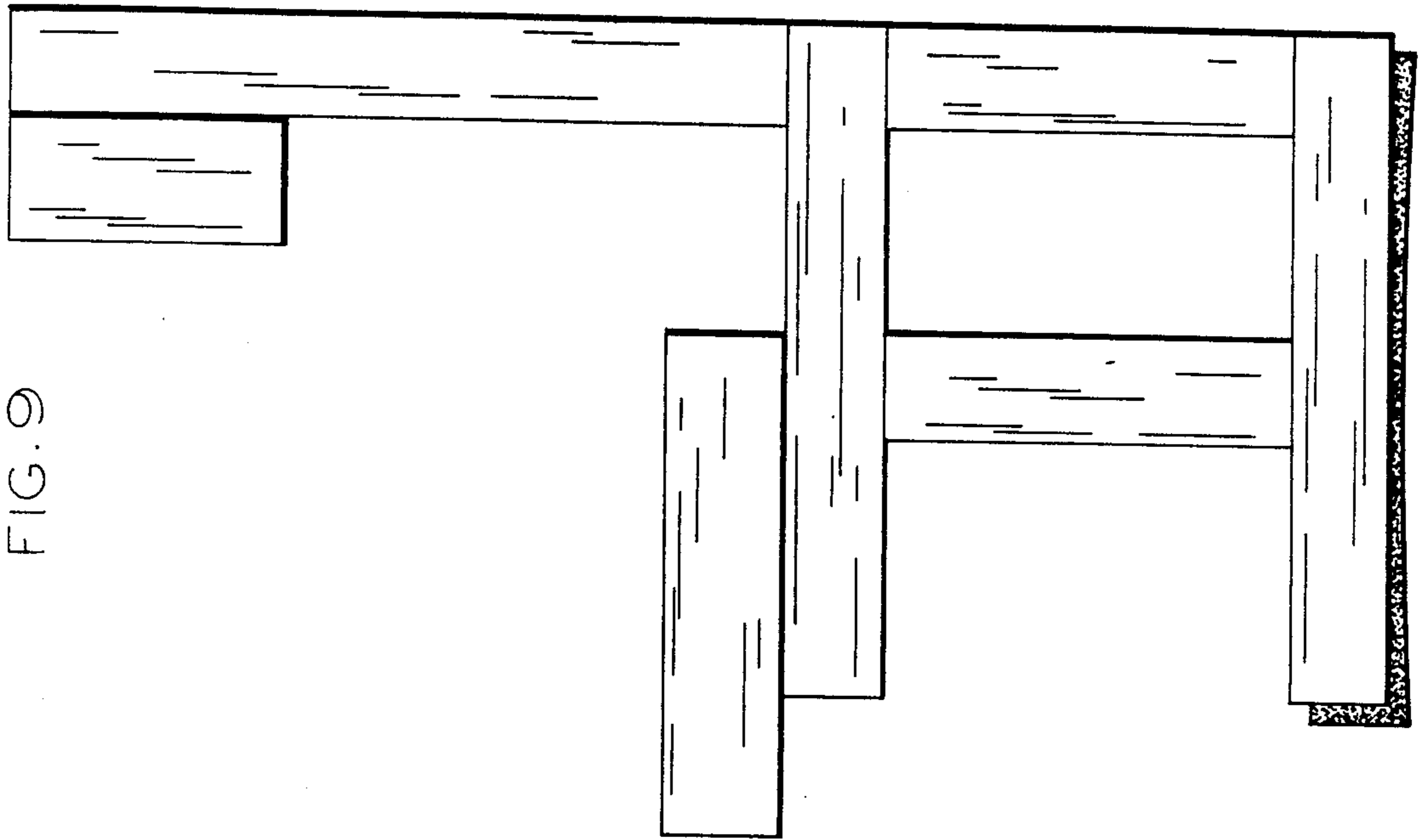

FIG. 9

FIG. 10

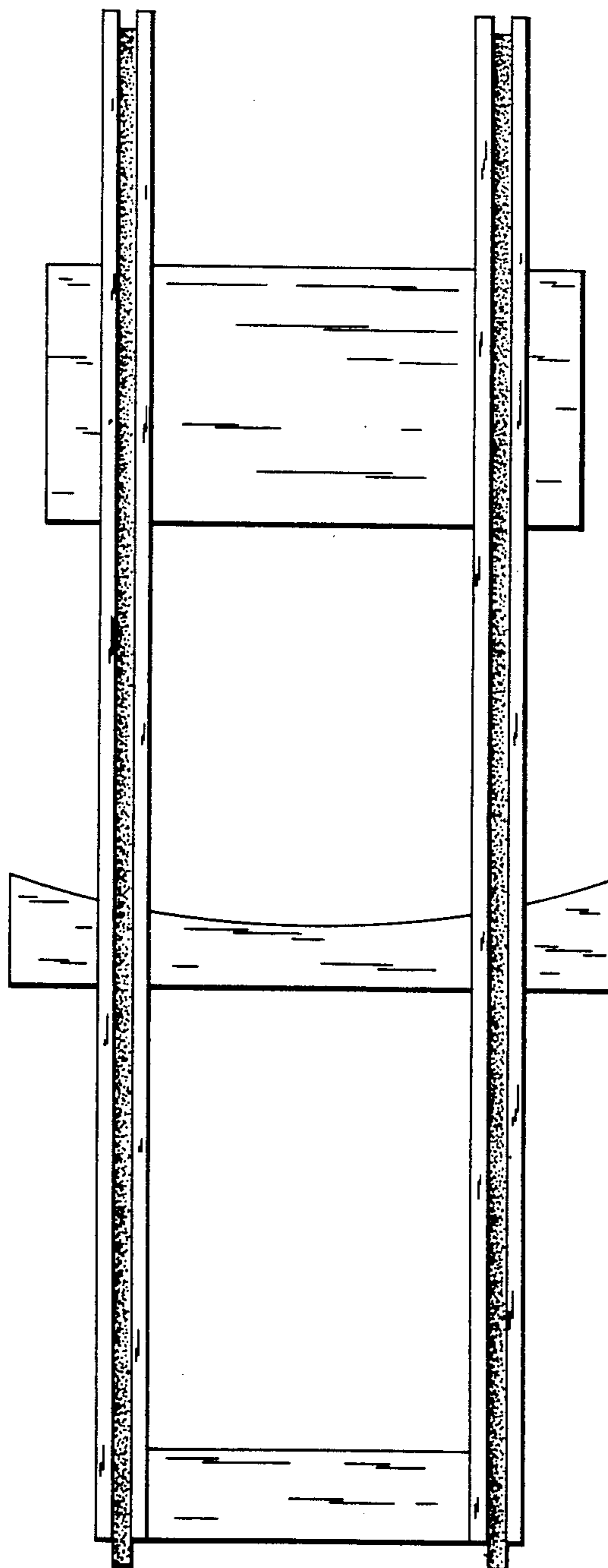
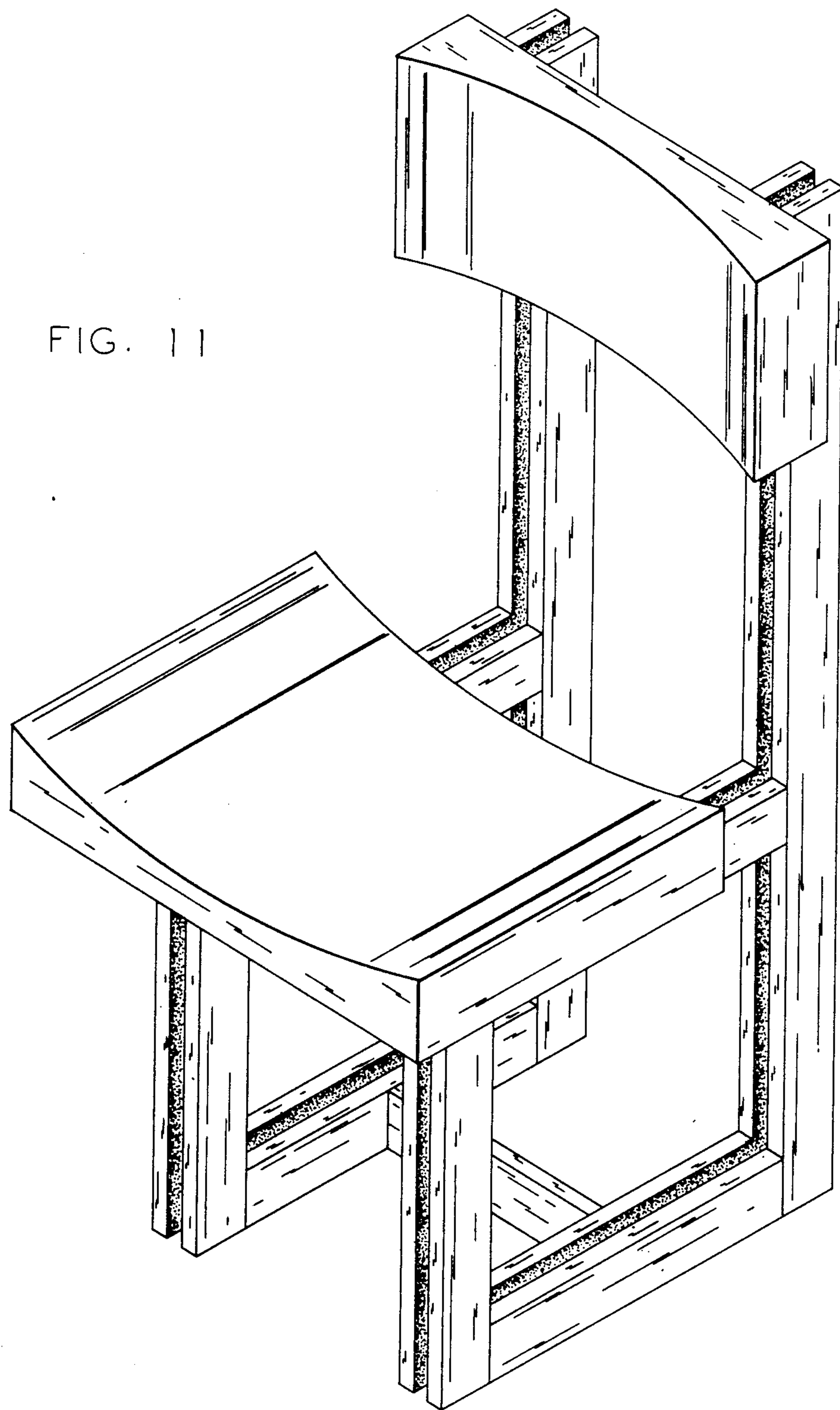

FIG. 11



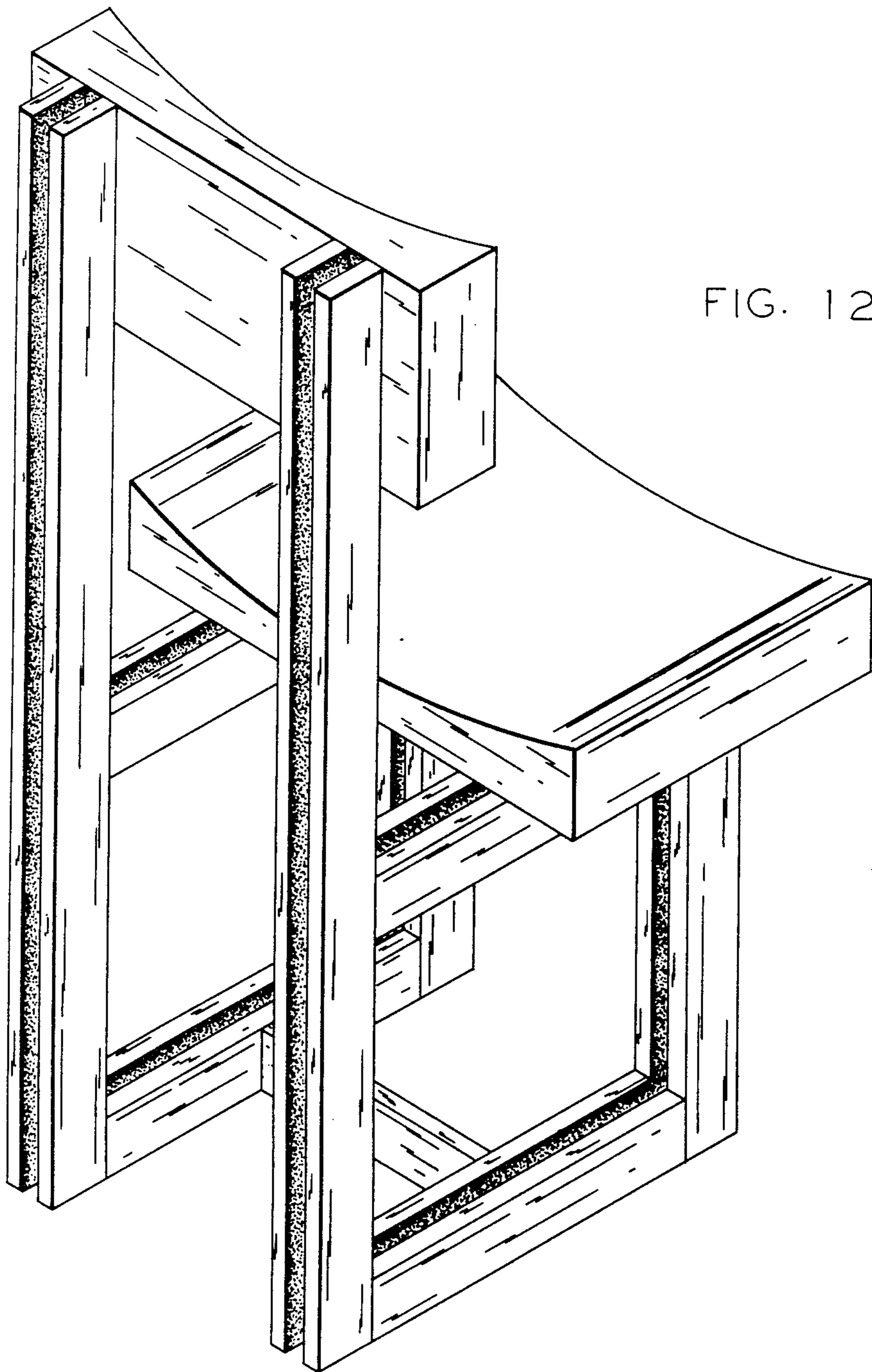

FIG. 12