

[54] **COMBINED MOTORCYCLE FAIRING WITH LOWER ATTACHMENTS**

[75] Inventor: **Craig W. Vetter, Rantoul, Ill.**

[73] Assignee: **Vetter Fairing Company, San Luis Obispo, Calif.**

[\*\*] Term: **14 Years**

[21] Appl. No.: **802,238**

[22] Filed: **May 31, 1977**

[51] Int. Cl. .... **D12-11**

[52] U.S. Cl. .... **D12/182**

[58] Field of Search ..... **D12/182; 296/78.1; 280/289 S**

[56] **References Cited**

**U.S. PATENT DOCUMENTS**

D. 242,339 11/1976 Vetter ..... D12/182

D. 242,340 11/1976 Vetter ..... D12/182

**OTHER PUBLICATIONS**

Cycle, 4/76, p. 70, Fairing, bottom left side of page.

Cycle, 6/76, p. 25, Free Spirit Fairing, top right side of page.

Cycle, 6/76, p. 111, Tour Master Fairing, bottom left side of page.

Cycle, 6/76, p. 116, Wixom Fairing.

Cycle, 4/76, p. 17, Fairing, center of page.

*Primary Examiner*—Wallace R. Burke

*Assistant Examiner*—James M. Gandy

*Attorney, Agent, or Firm*—Ernest A. Wegner

[57] **CLAIM**

The ornamental design for a combined motorcycle fairing with lower attachments, as shown and described.

**DESCRIPTION**

FIG. 1 is a front elevation view of a combined motorcycle fairing with lower attachments showing the new design;

FIG. 2 is a rear elevation view thereof;

FIG. 3 is a right side elevation view thereof;

FIG. 4 is a left side elevation view thereof;

FIG. 5 is a top plan view thereof;

FIG. 6 is an enlarged outside elevation view of the right lower attachment;

FIG. 7 is an enlarged outside elevation view of the left lower attachment;

FIG. 8 is an enlarged inside elevation view of the right lower attachment;

FIG. 9 is an enlarged inside elevation view of the left lower attachment;

FIG. 10 is an enlarged top plan view of the left lower attachment;

FIG. 11 is an enlarged bottom plan view of the left lower attachment;

FIG. 12 is an enlarged rear elevation view of the left lower attachment;

FIG. 13 is an enlarged front elevation view of the left lower attachment;

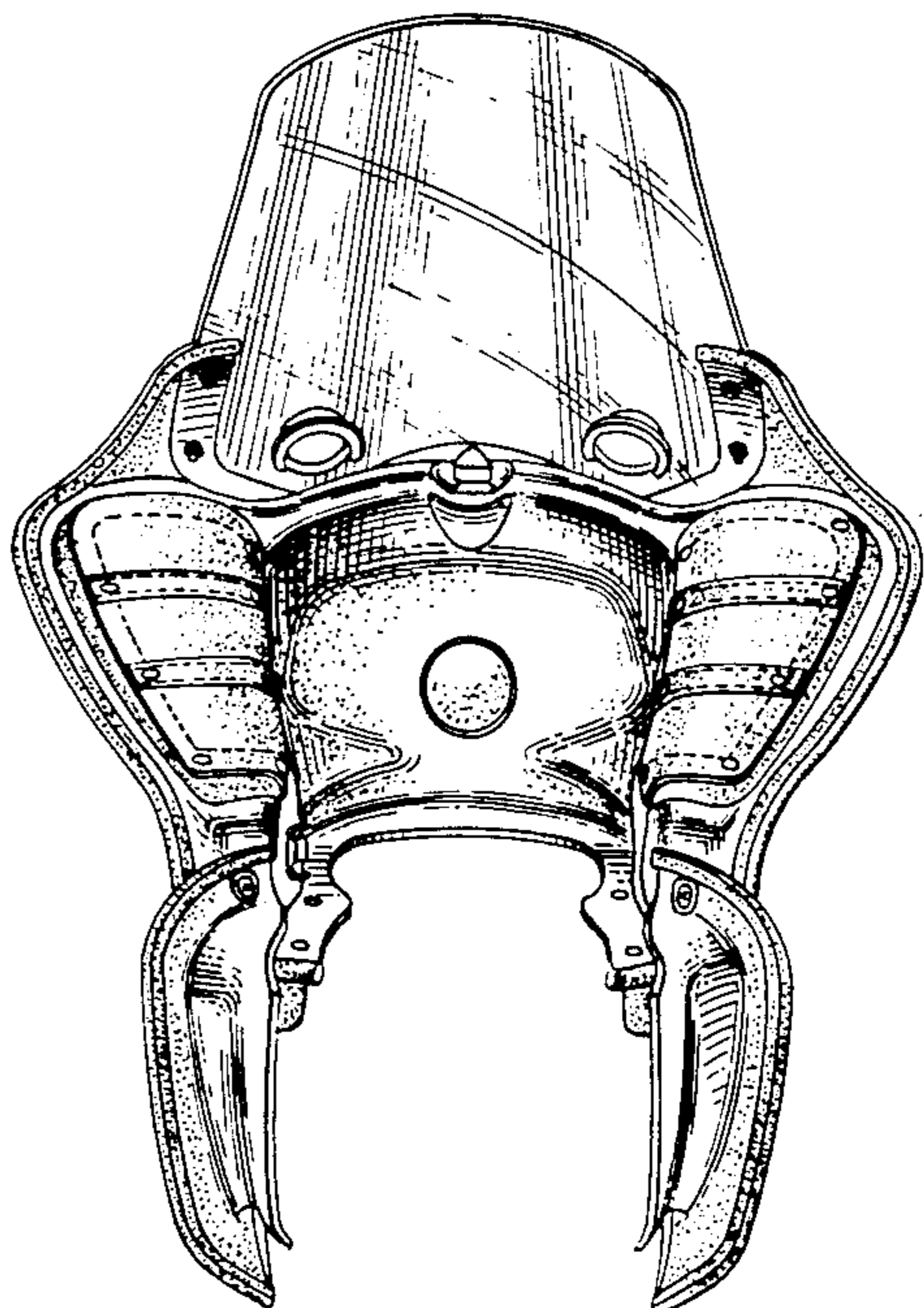
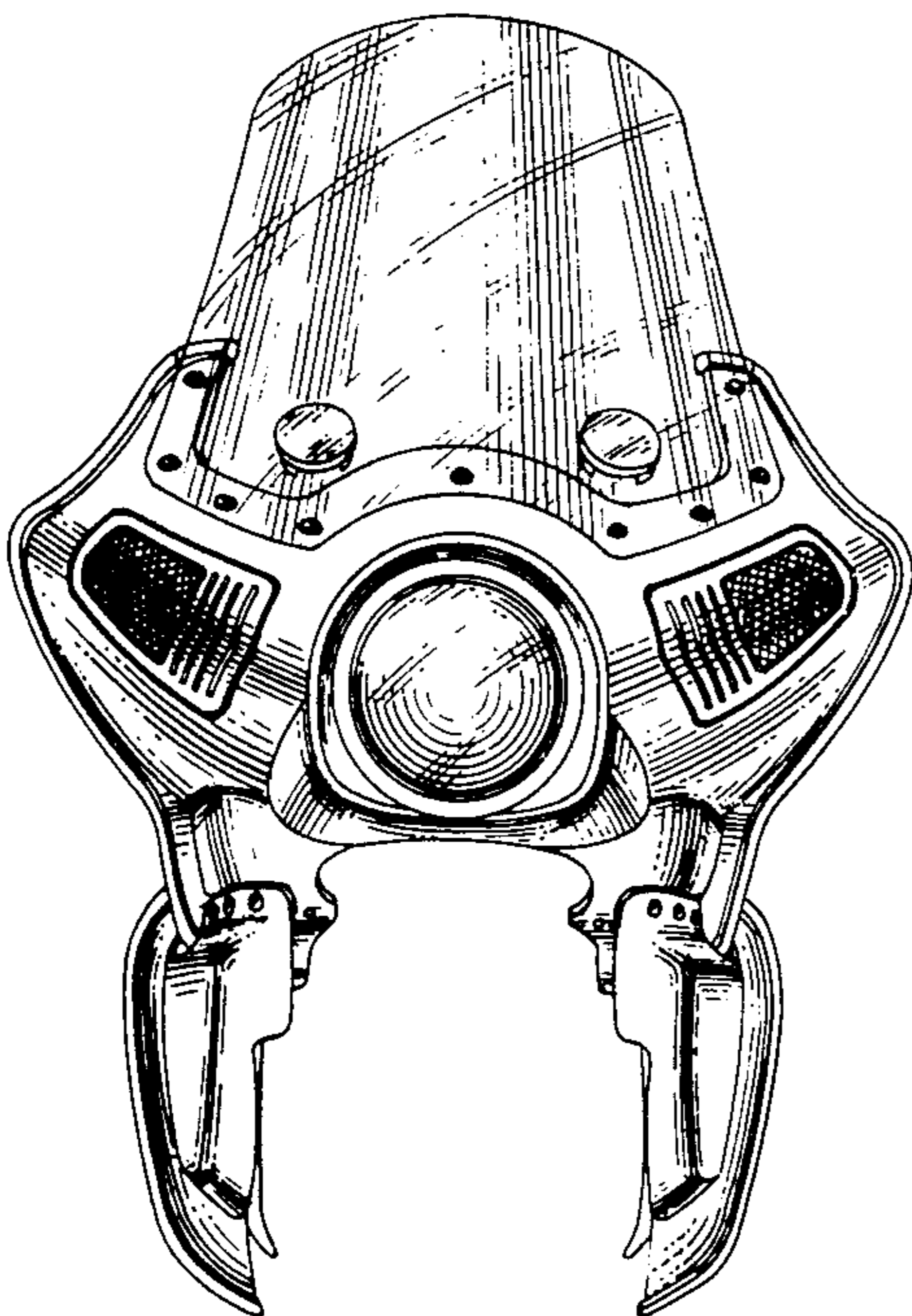
FIG. 14 is an enlarged bottom plan view of the right lower attachment;

FIG. 15 is an enlarged top plan view of the right lower attachment;

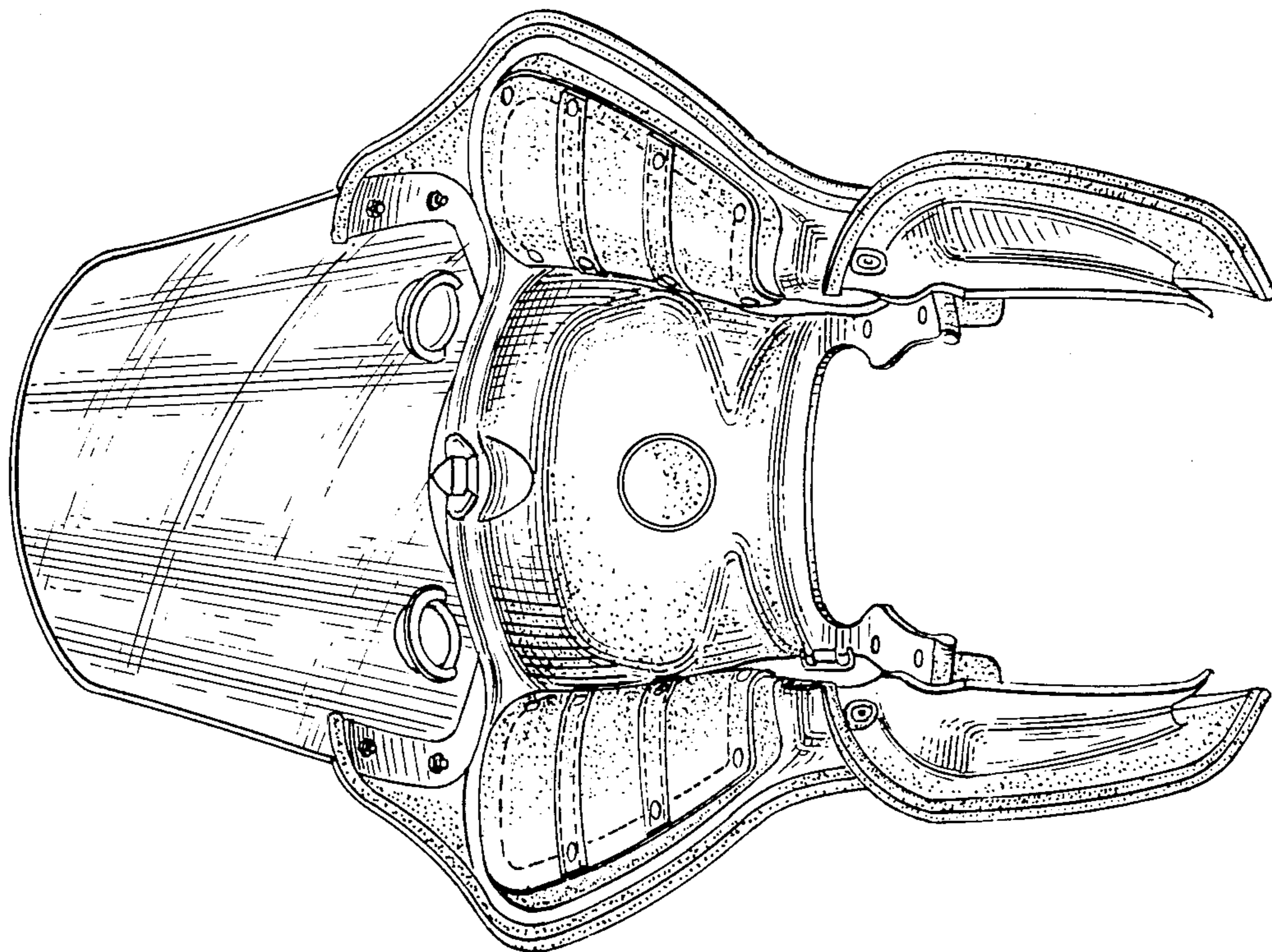
FIG. 16 is an enlarged front elevation view of the right lower attachment; and

FIG. 17 is an enlarged rear elevation view of the right lower attachment.

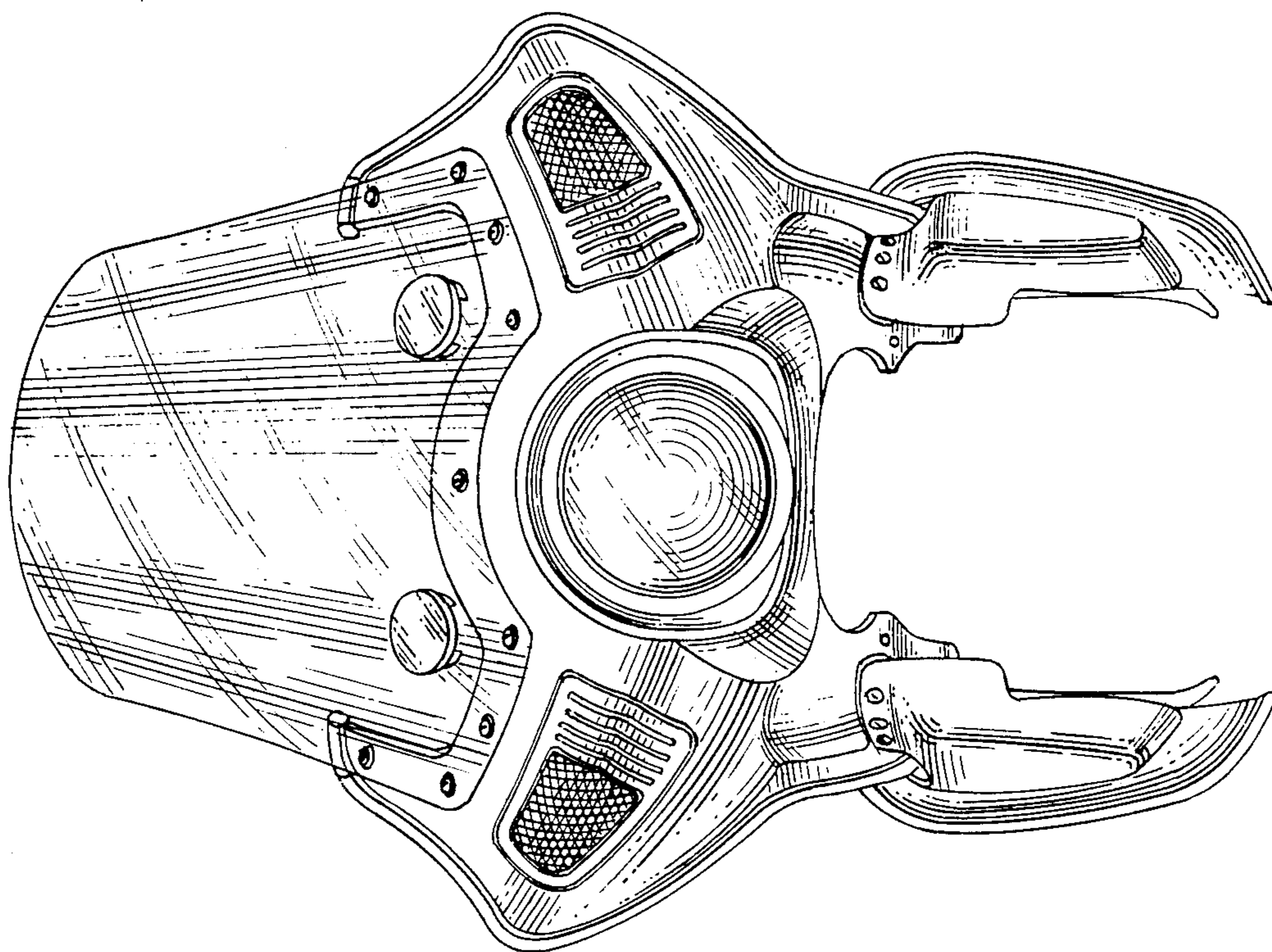
The broken line representations of a portion of a motorcycle in FIGS. 3 and 4 illustrate the environment in which the fairing with lower attachments is used but form no part of the claimed design. The motorcycle fairing has been omitted in FIGS. 6-17 for clarity of illustration.

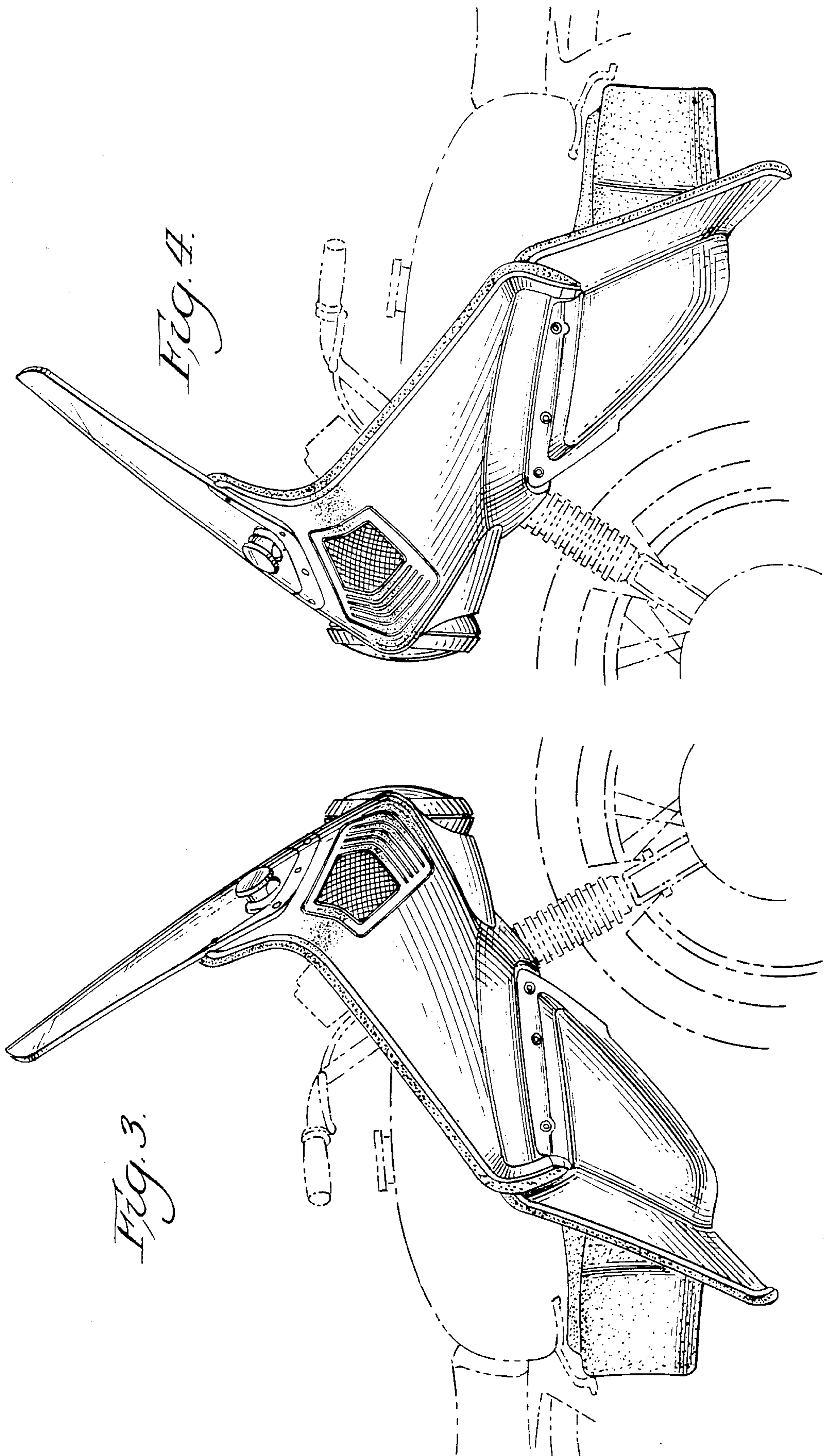


*Fig. 2.*



*Fig. 1.*

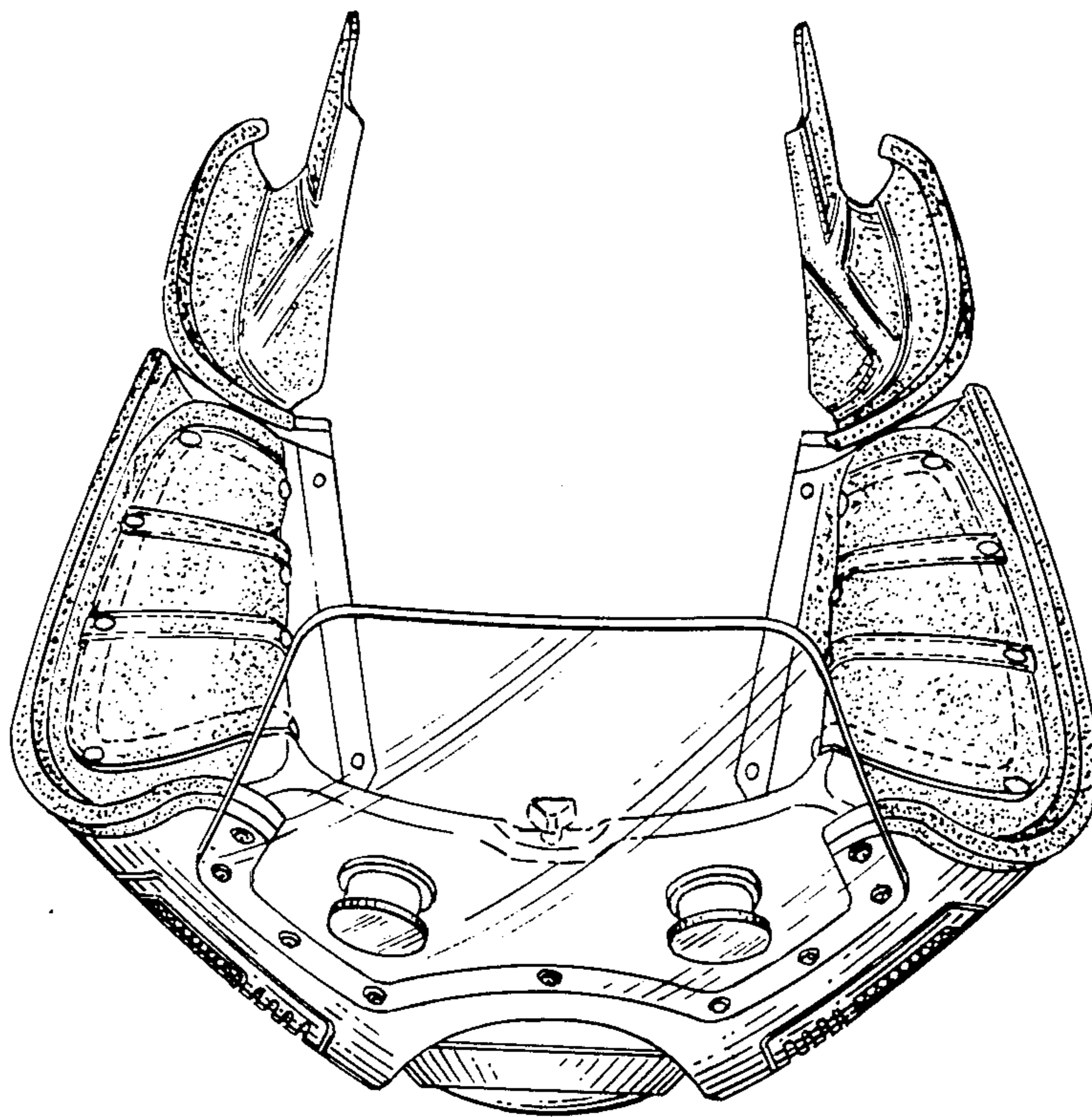


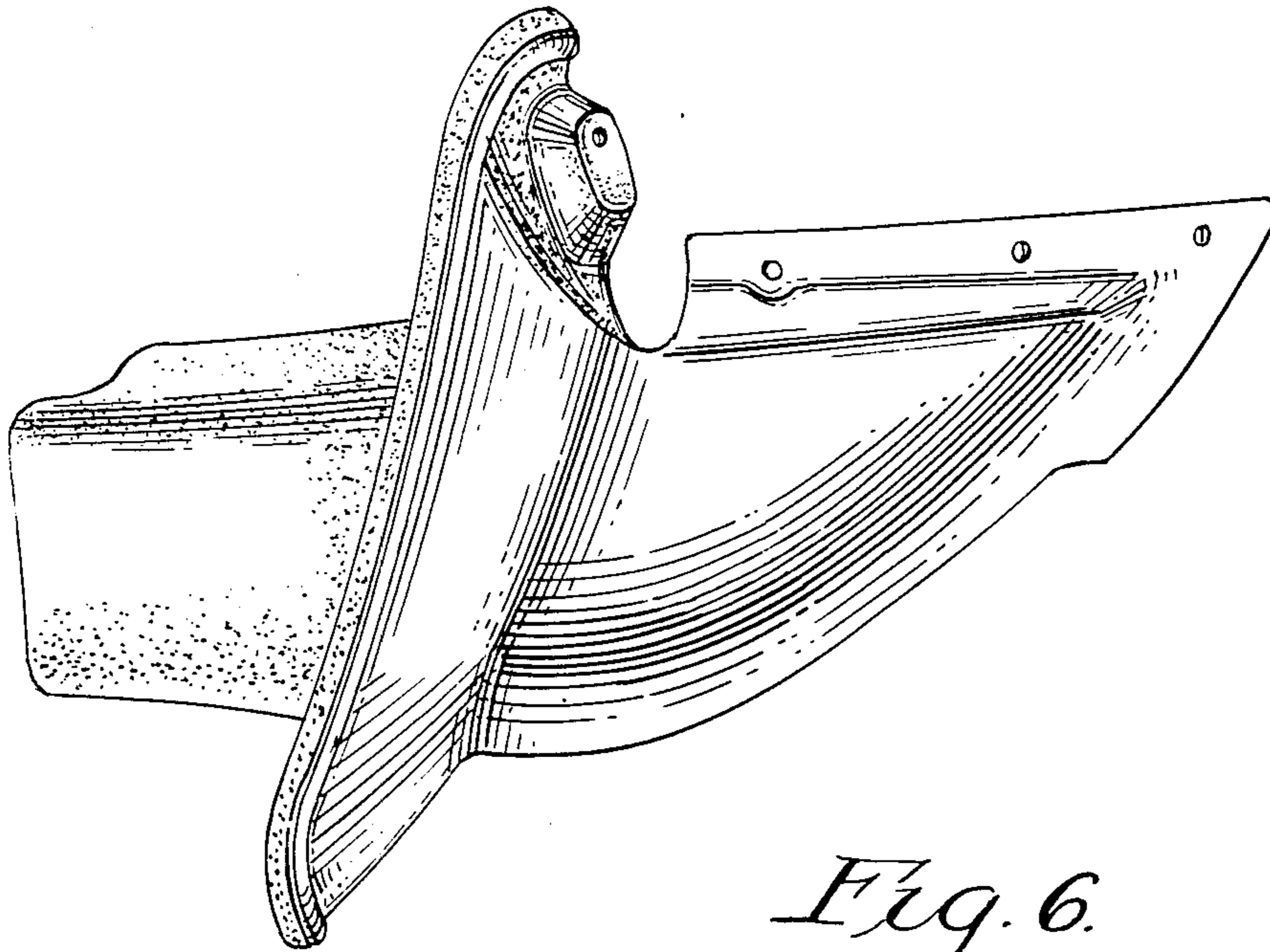


*Fig. 4.*

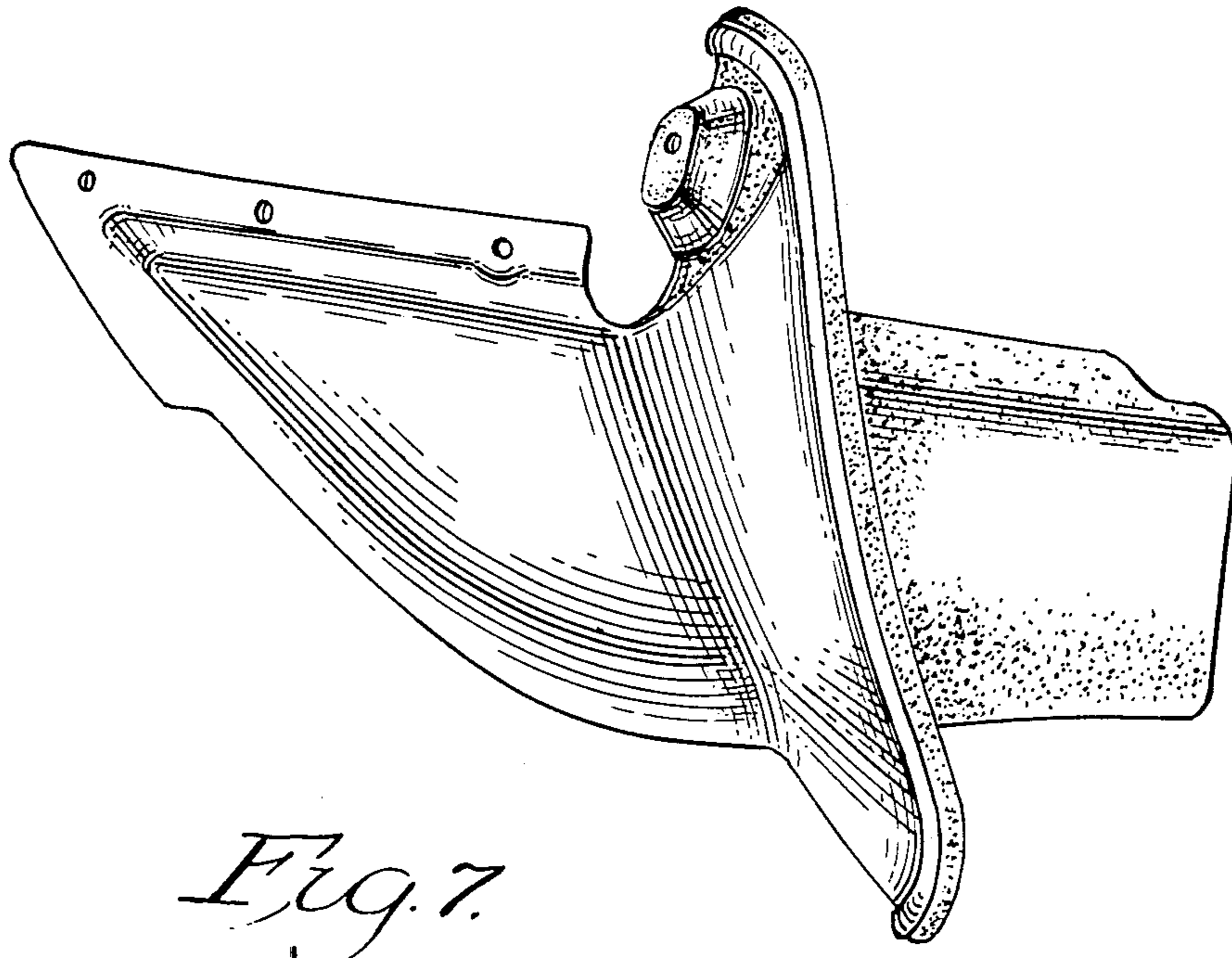
*Fig. 3.*

*Fig. 5.*

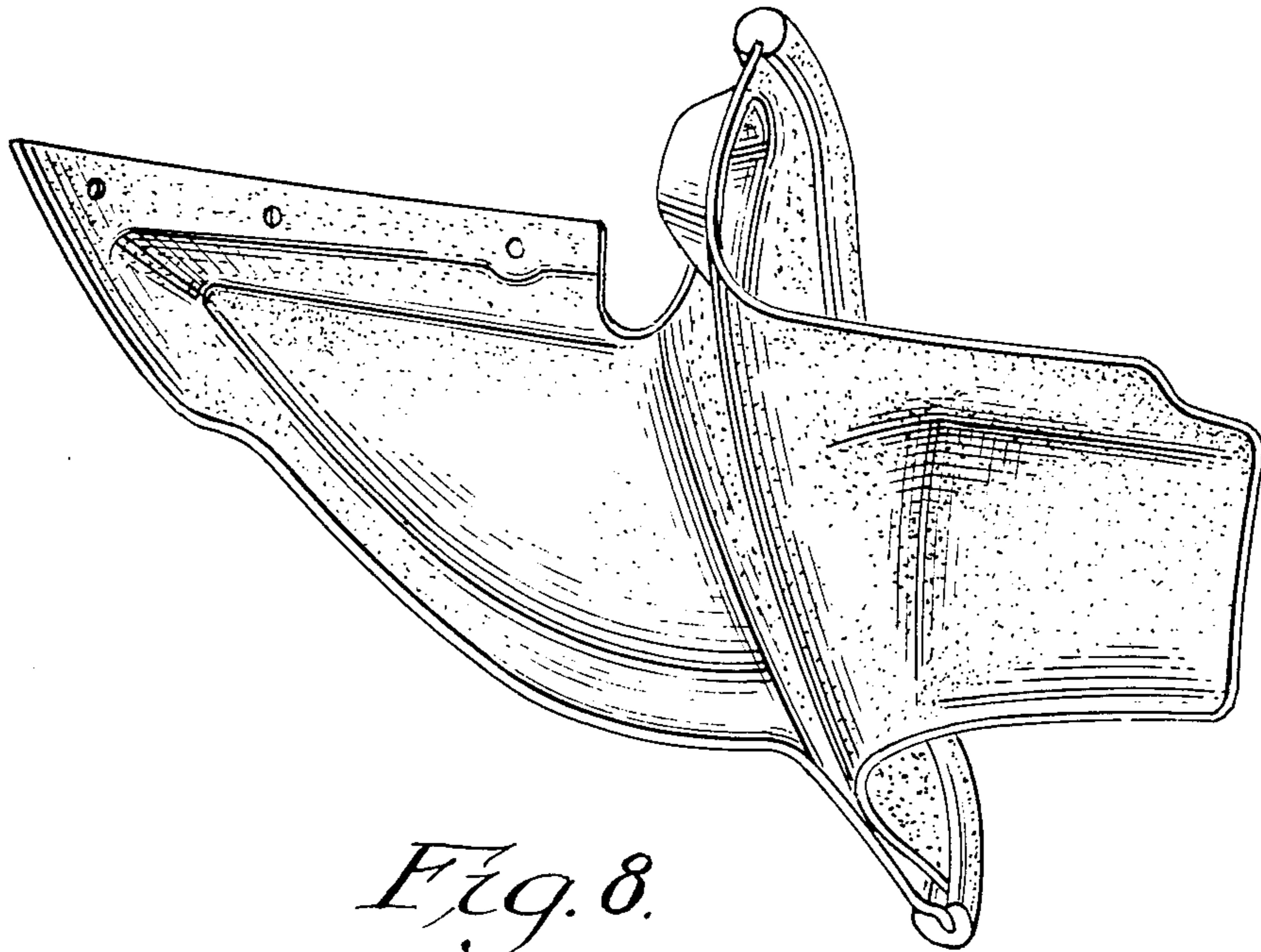




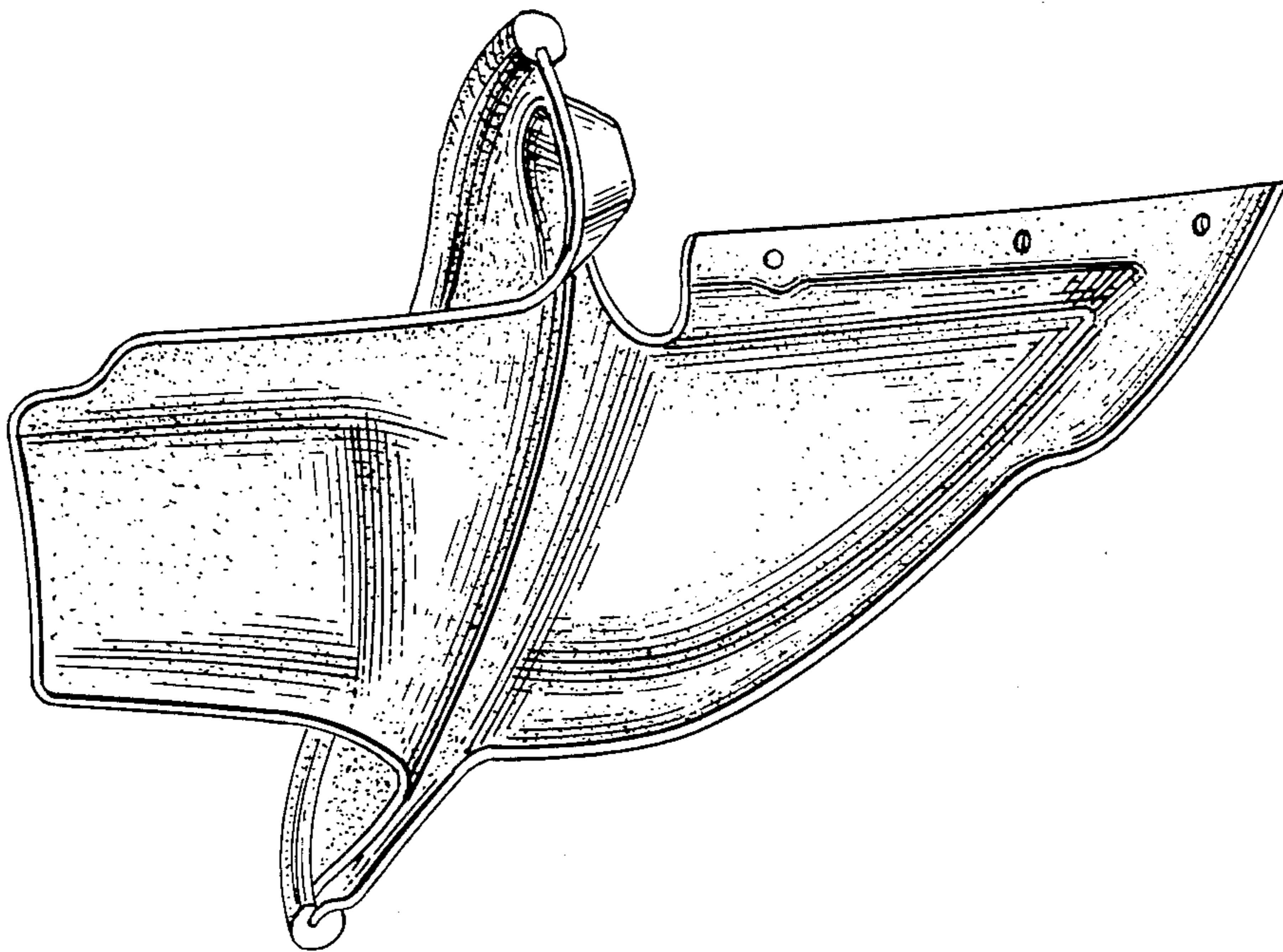
*Fig. 6.*



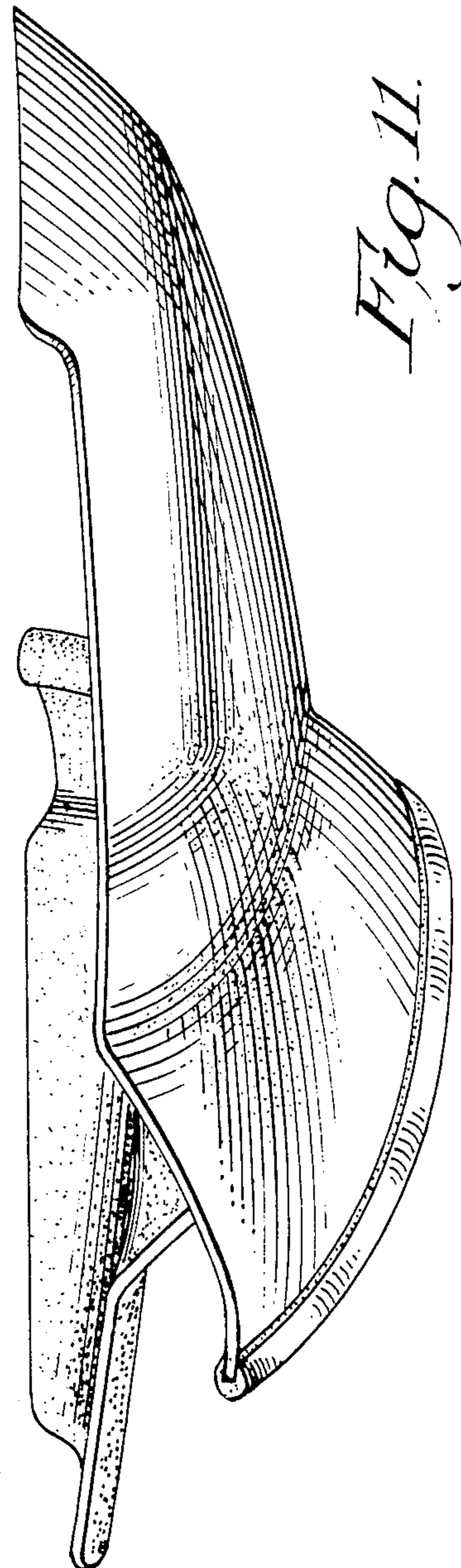
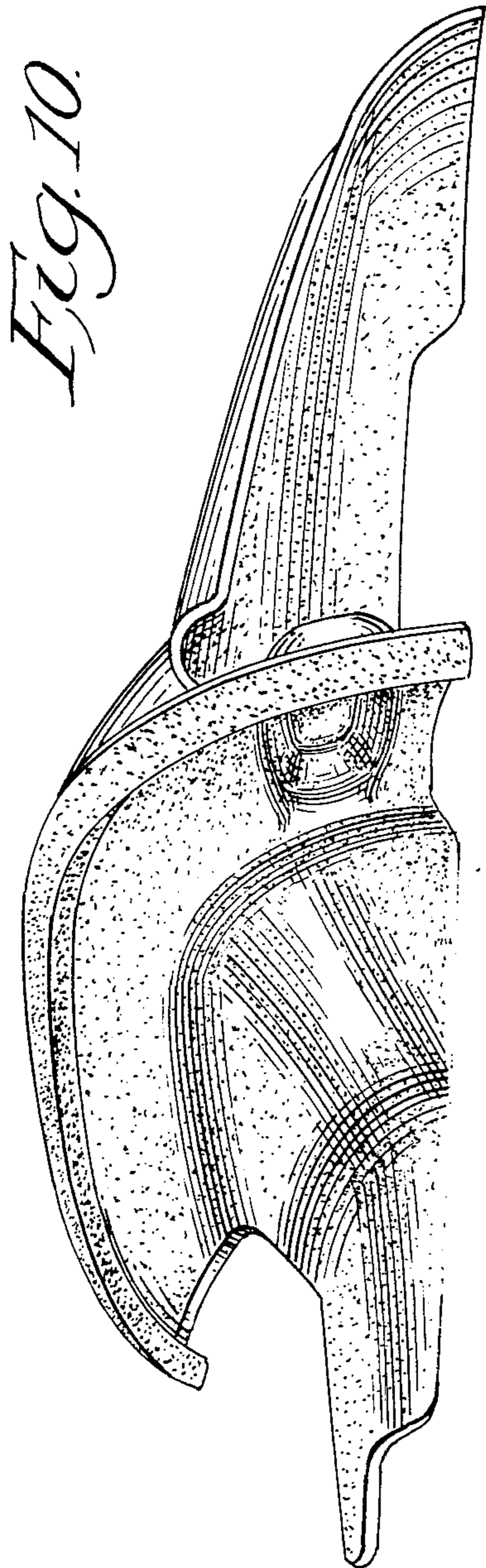
*Fig. 7.*



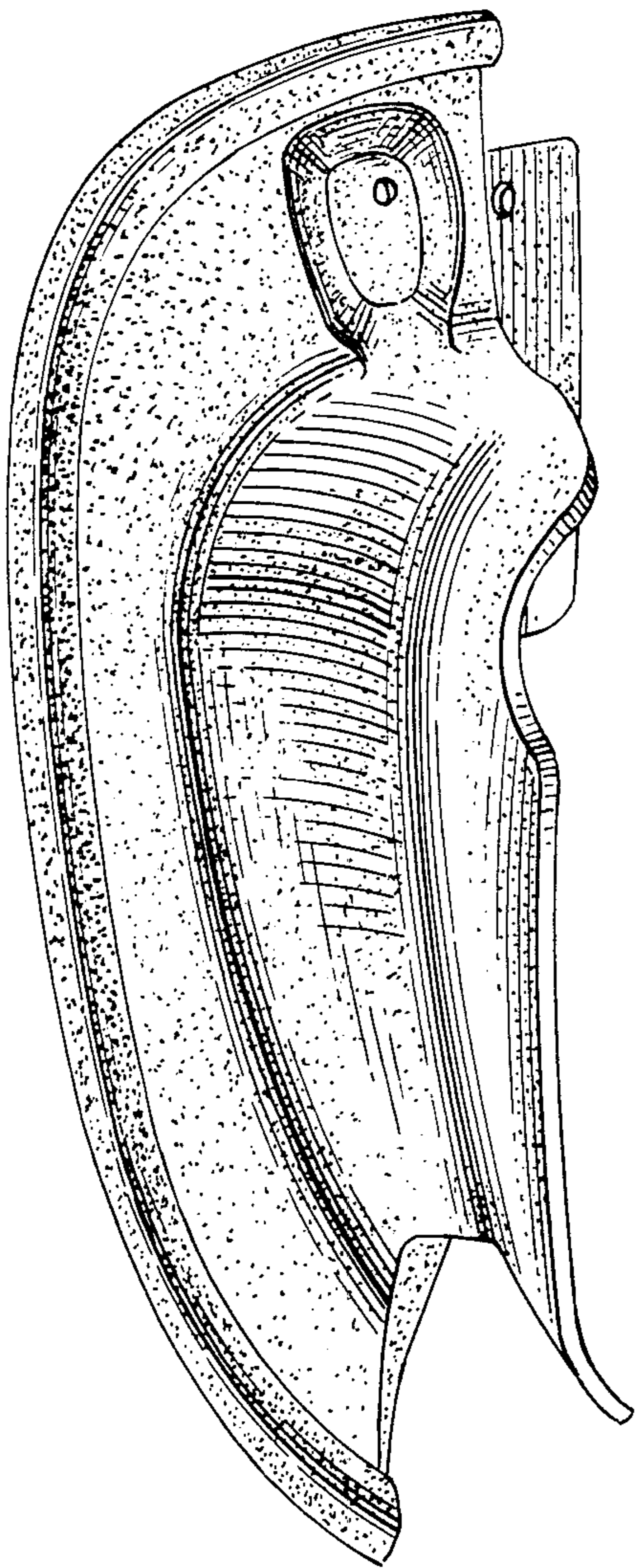
*Fig. 8.*



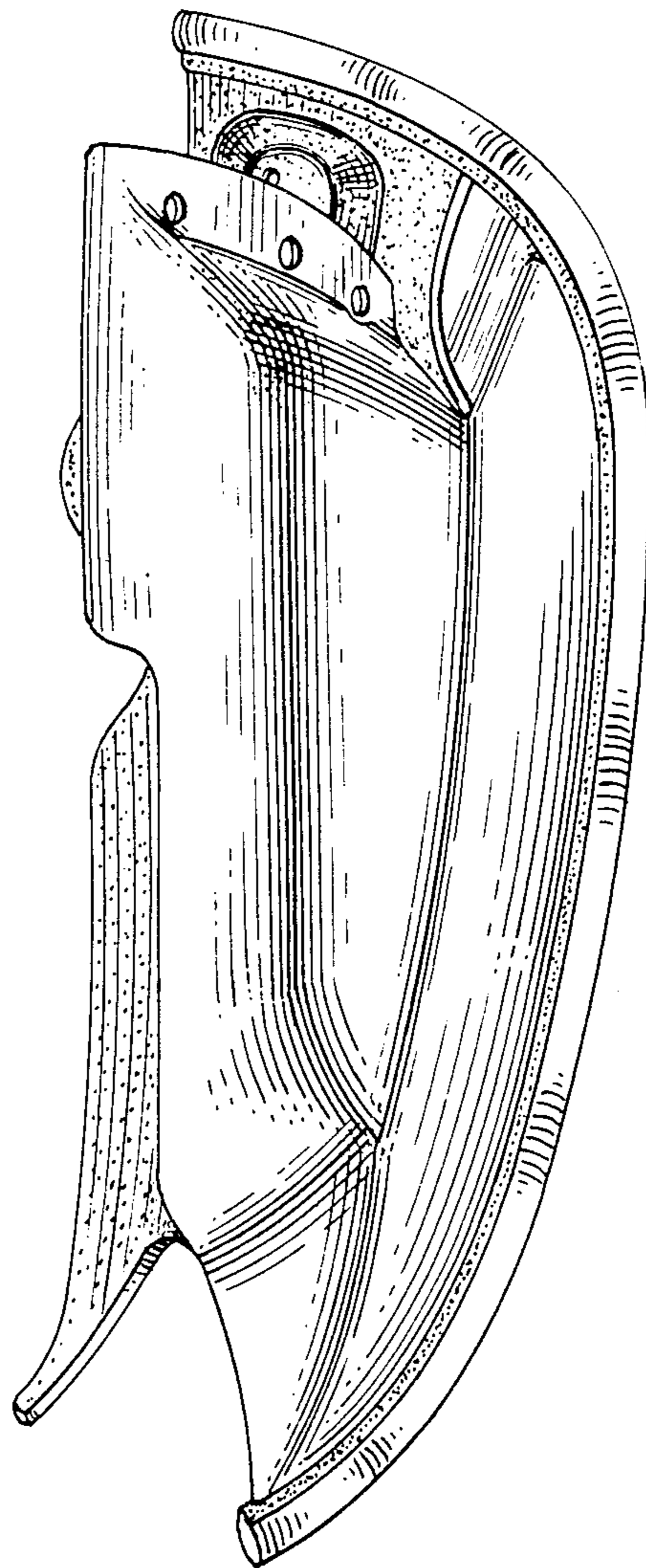
*Fig. 9.*



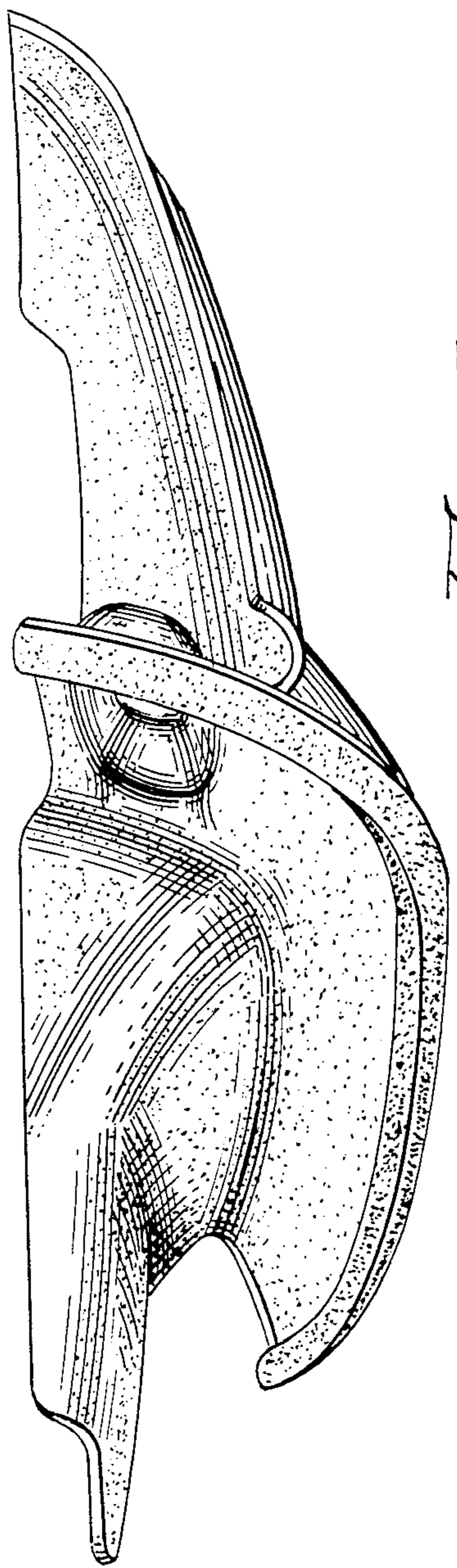
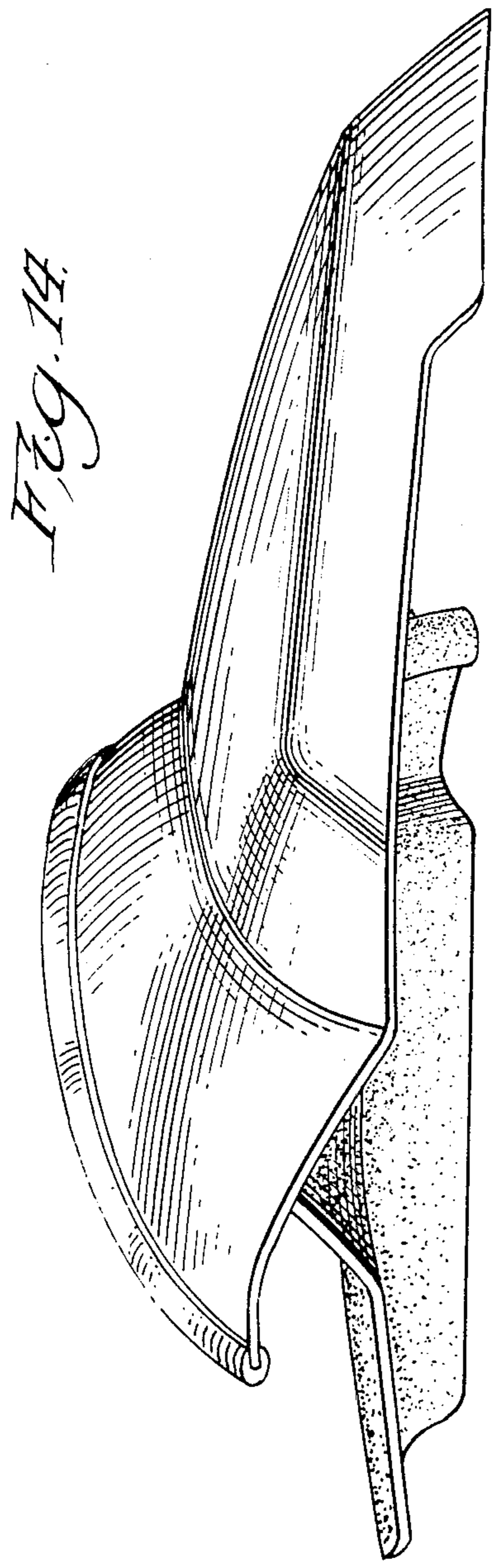
*Fig. 12.*



*Fig. 13.*







*Fig. 16.*

*Fig. 17.*

