

[54] TRUCK WIND DEFLECTOR

[76] Inventor: Donald R. Herpel, 29466  
Candlewood, Southfield, Mich.  
48076

[\*\*] Term: 14 Years

[21] Appl. No.: 705,901

[22] Filed: Jul. 16, 1976

[51] Int. Cl. .... D12-16

[52] U.S. Cl. .... D12/181; D12/96

[58] Field of Search ..... D12/181, 93, 96;  
296/1 S, 1 R, 91

[56] References Cited

U.S. PATENT DOCUMENTS

D. 238,161	12/1975	De Vaughn	.....	D12/181
3,309,131	3/1967	Saunders	.....	296/1 S
3,814,472	6/1974	Zelikovitz	.....	296/1 S
3,972,556	8/1976	Mason, Jr.	.....	296/1 S

FOREIGN PATENT DOCUMENTS

934,592	1/1948	France	.....	296/1 S
---------	--------	--------	-------	---------

2,437,075 2/1976 Fed. Rep. of Germany ..... 296/1 S

OTHER PUBLICATIONS

R. V. Dealer, 9/74, p. 79, Ayr-A-Way Wind Deflector, center left side of page.

Commercial Car Journal, 7/67, p. 170, Air deflector, top right side of page.

Primary Examiner—Wallace R. Burke

Assistant Examiner—James M. Gandy

Attorney, Agent, or Firm—Ralph M. Burton

[57] CLAIM

The ornamental design for a truck wind deflector, as shown and described.

DESCRIPTION

FIG. 1 is a perspective view of a truck wind deflector showing my new design;

FIG. 2 is a front elevation view thereof;

FIG. 3 is a top plan view thereof;

FIG. 4 is a side elevation view thereof; and

FIG. 5 is a rear elevation view thereof.

The broken lines in the drawing are for illustrative purposes only.

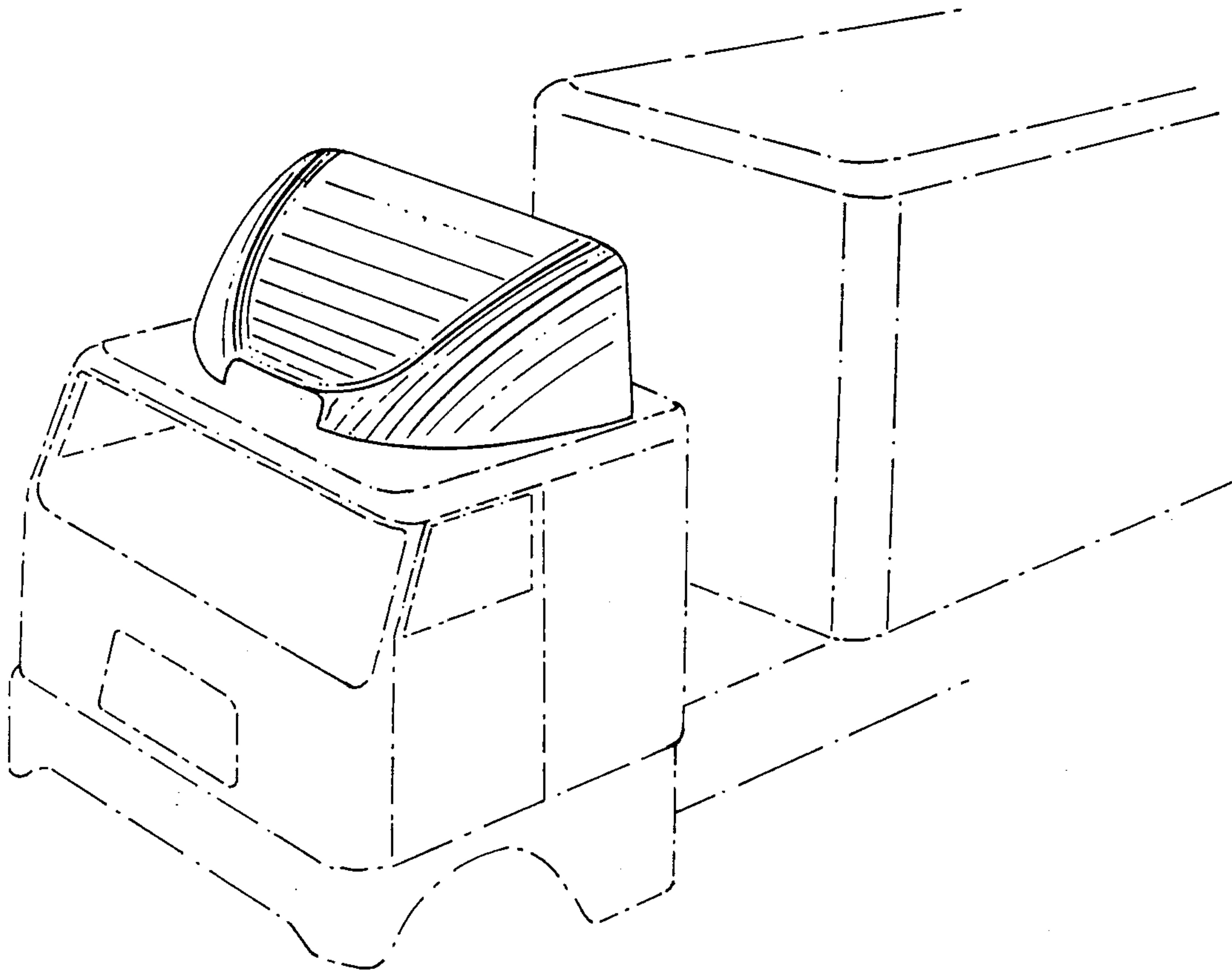

FIG. 1

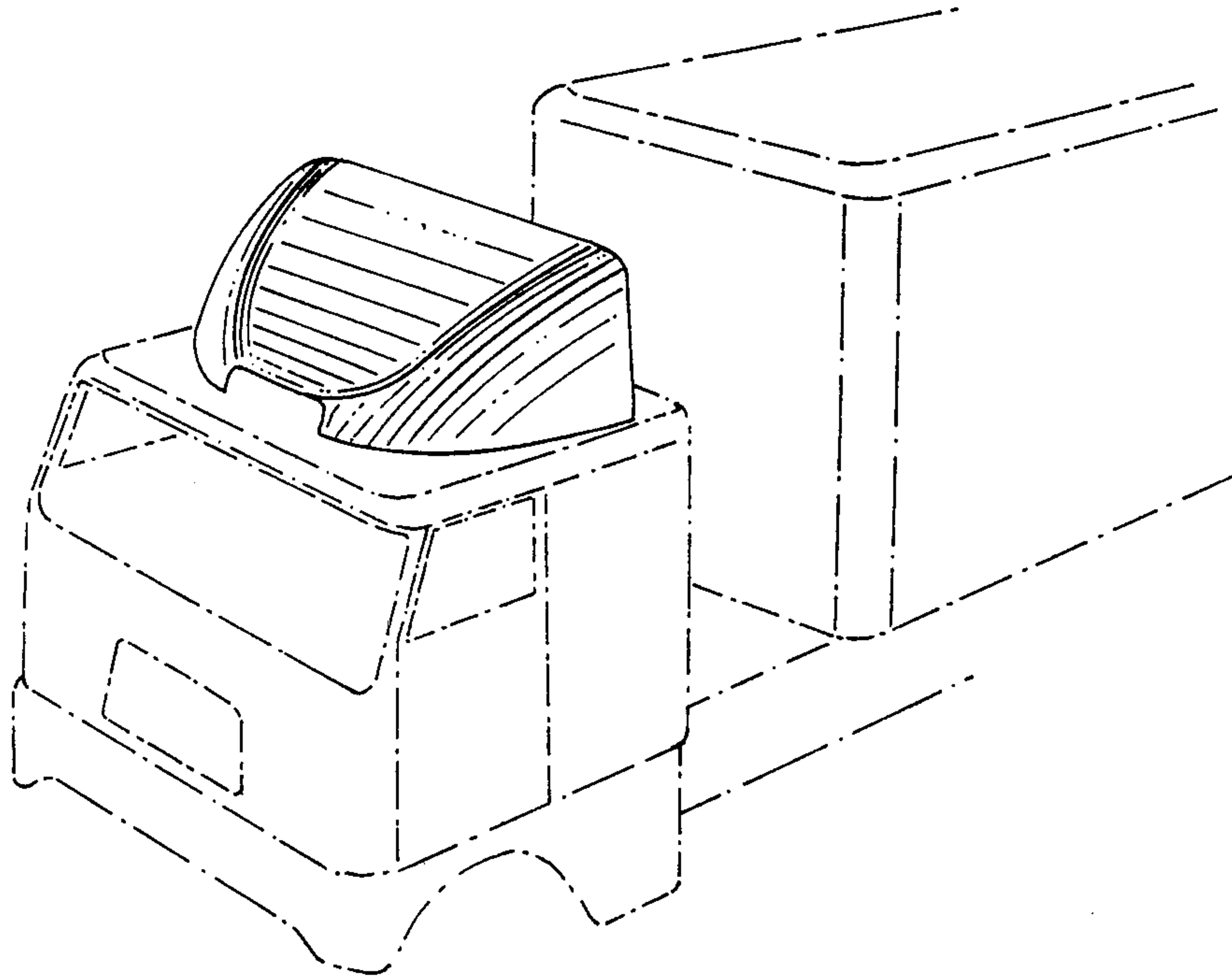

FIG. 2

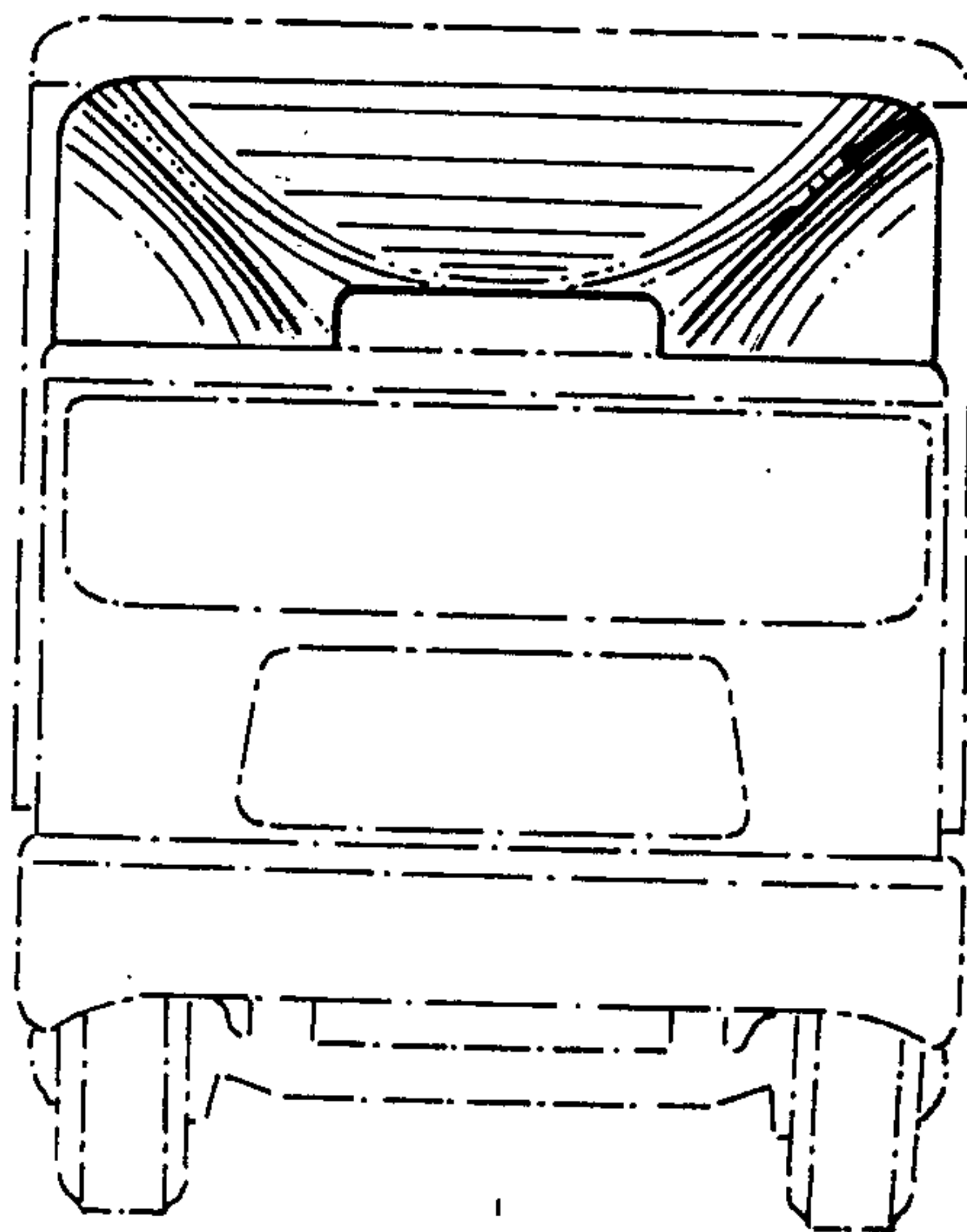

FIG. 3

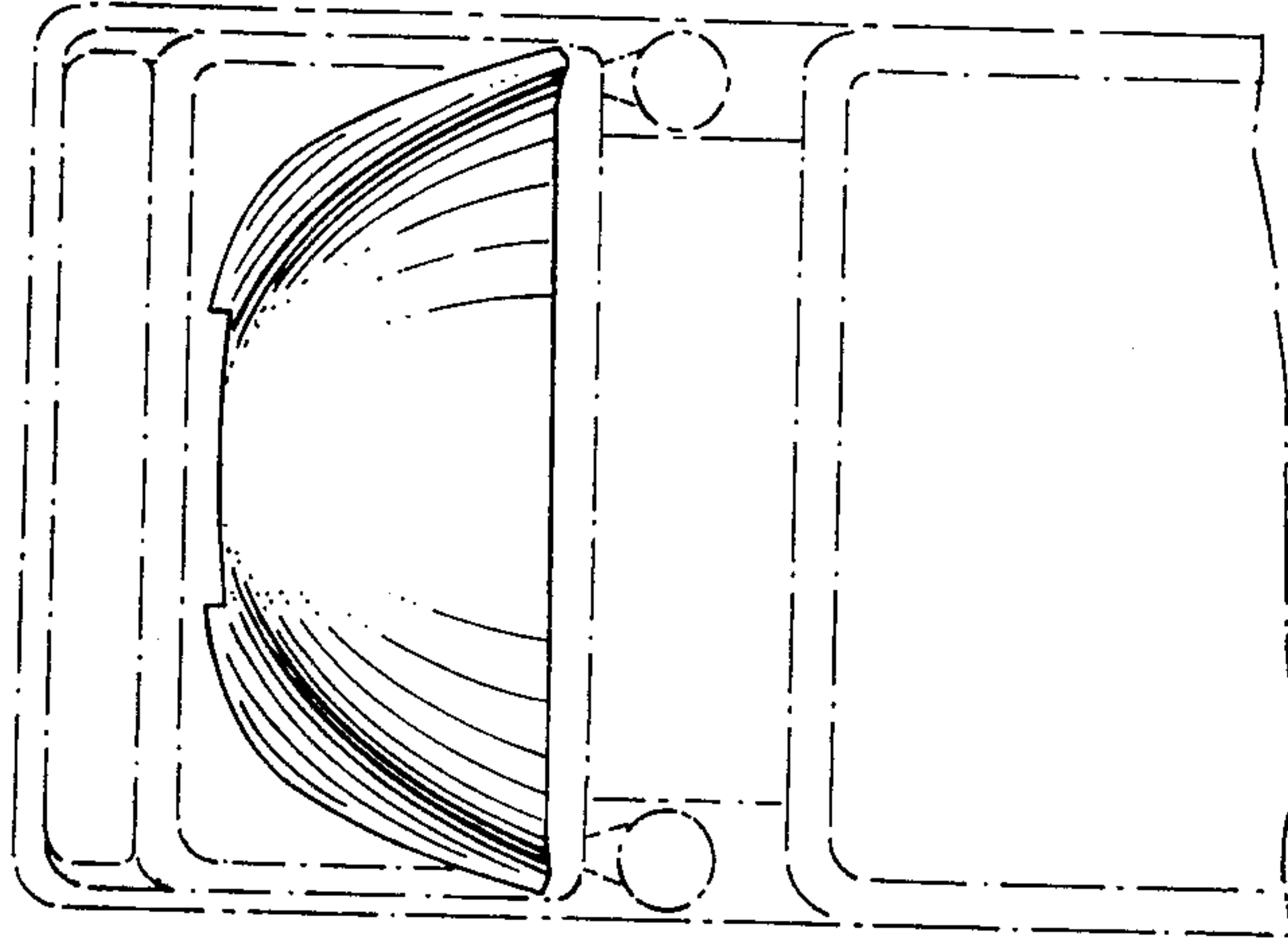

FIG. 4

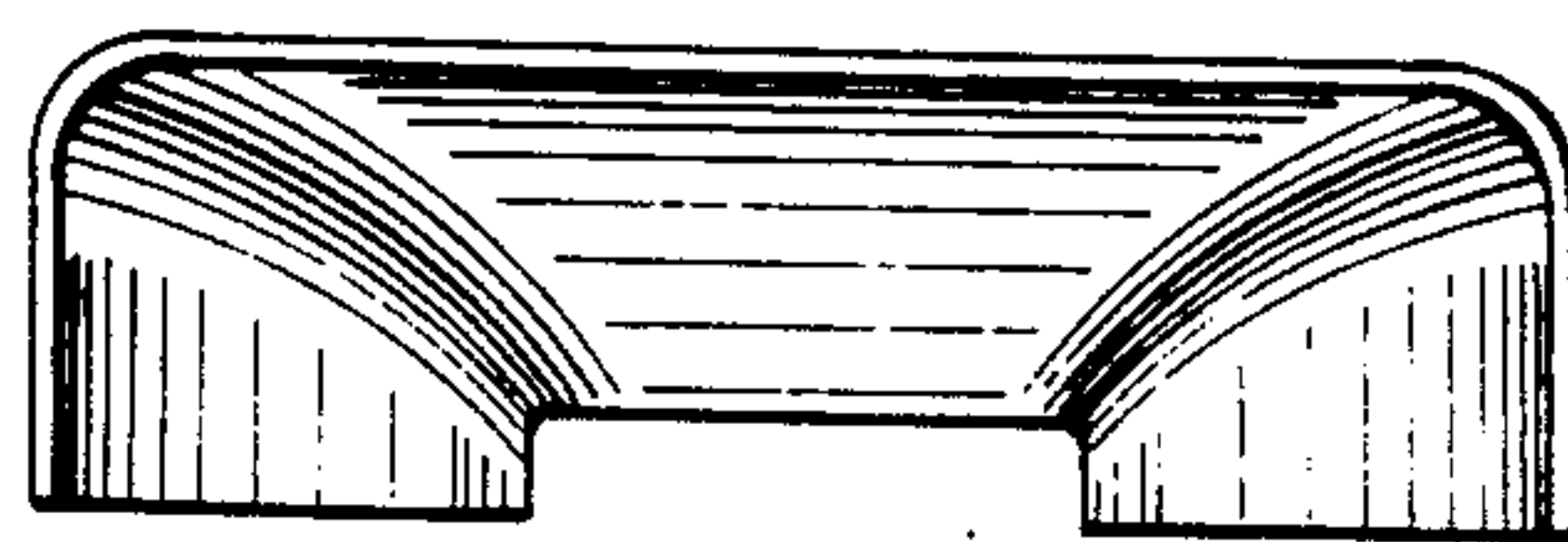
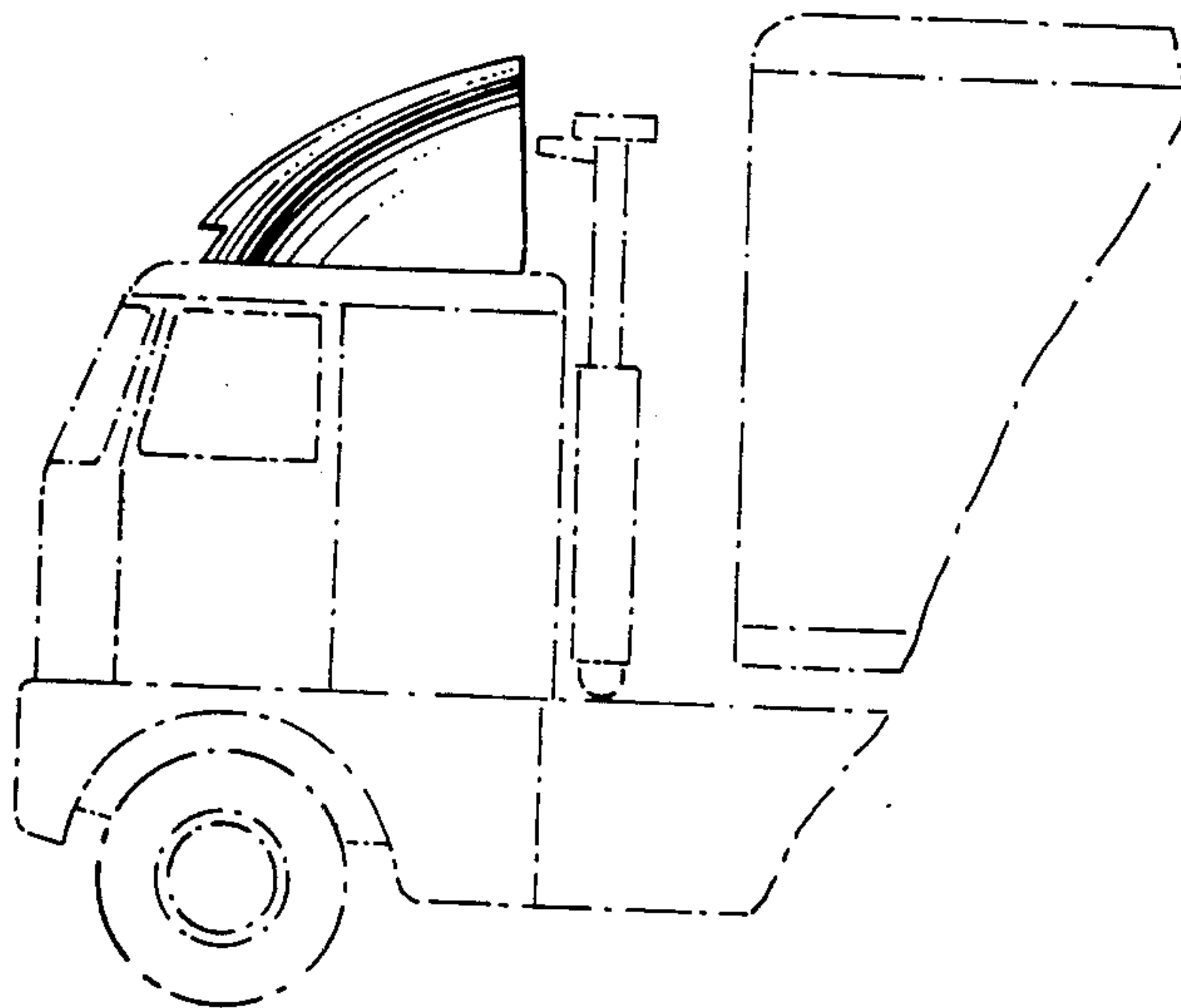

FIG. 5.