

- [54] WHEEL
- [76] Inventor: **Bruce N. Smith, c/o Spherex Inc.,
Seabrook, N.H. 03874**
- [**] Term: **14 Years**
- [21] Appl. No.: **797,590**
- [22] Filed: **May 16, 1977**
- [51] Int. Cl. **D12-16**
- [52] U.S. Cl. **D12/205**
- [58] Field of Search **D12/205, 204; 301/58,
301/59, 63 R, 63 PW, 64 R, 64 SD, 65, 66, 73,
74, 79, 86**

- [56] **References Cited**
U.S. PATENT DOCUMENTS
D. 214,728 7/1969 Reid **D12/205**

- D. 221,833 9/1971 Haydock et al. **D12/204**
- D. 224,221 7/1972 DePuydt et al. **D12/205**

Primary Examiner—Wallace R. Burke
Assistant Examiner—James M. Gandy
Attorney, Agent, or Firm—Norman S. Blodgett

[57] **CLAIM**

The ornamental design for a wheel, as shown.

DESCRIPTION

FIG. 1 is a front elevational view of the wheel showing my new design,
 FIG. 2 is a sectional view thereof taken on the line II—II of FIG. 1,
 FIG. 3 is a rear elevational view thereof,
 FIG. 4 is a right side elevational view thereof,
 FIG. 5 is a left side elevational view thereof,
 FIG. 6 is a top plan view thereof, and
 FIG. 7 is a bottom plan view thereof.

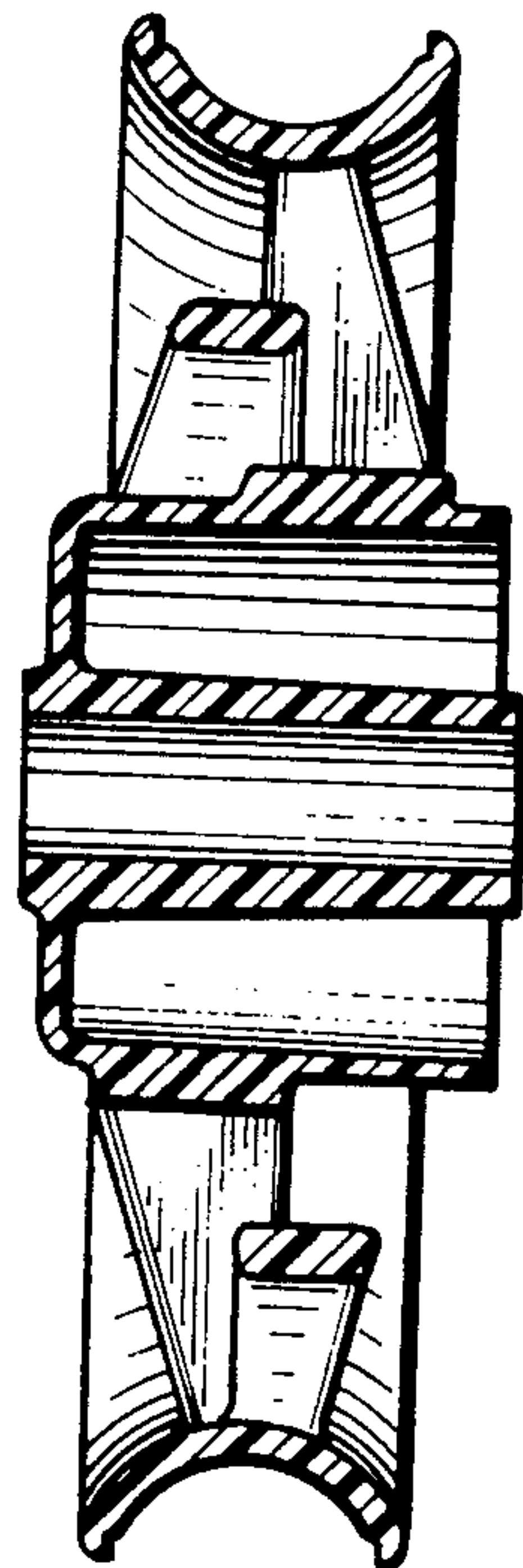
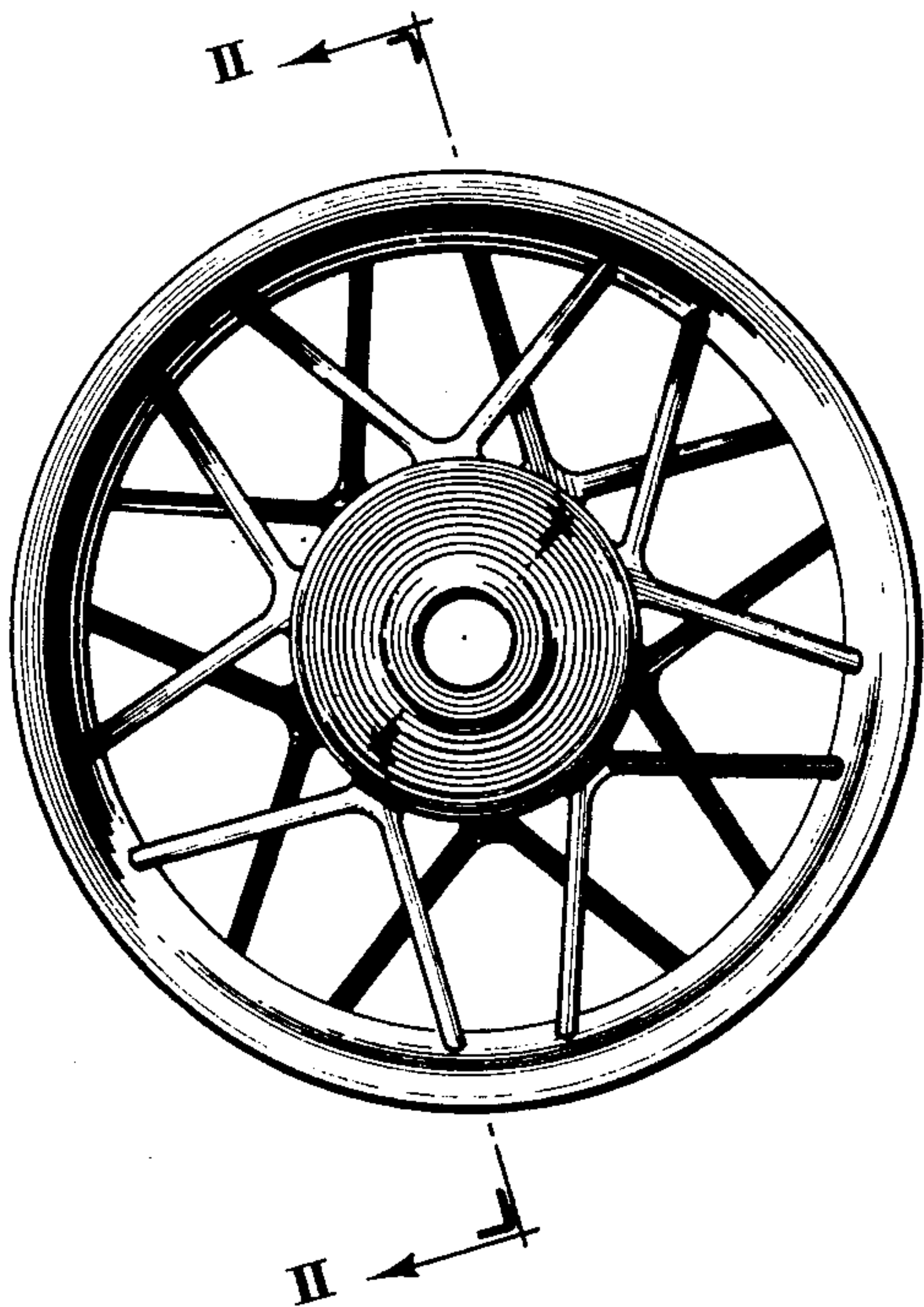

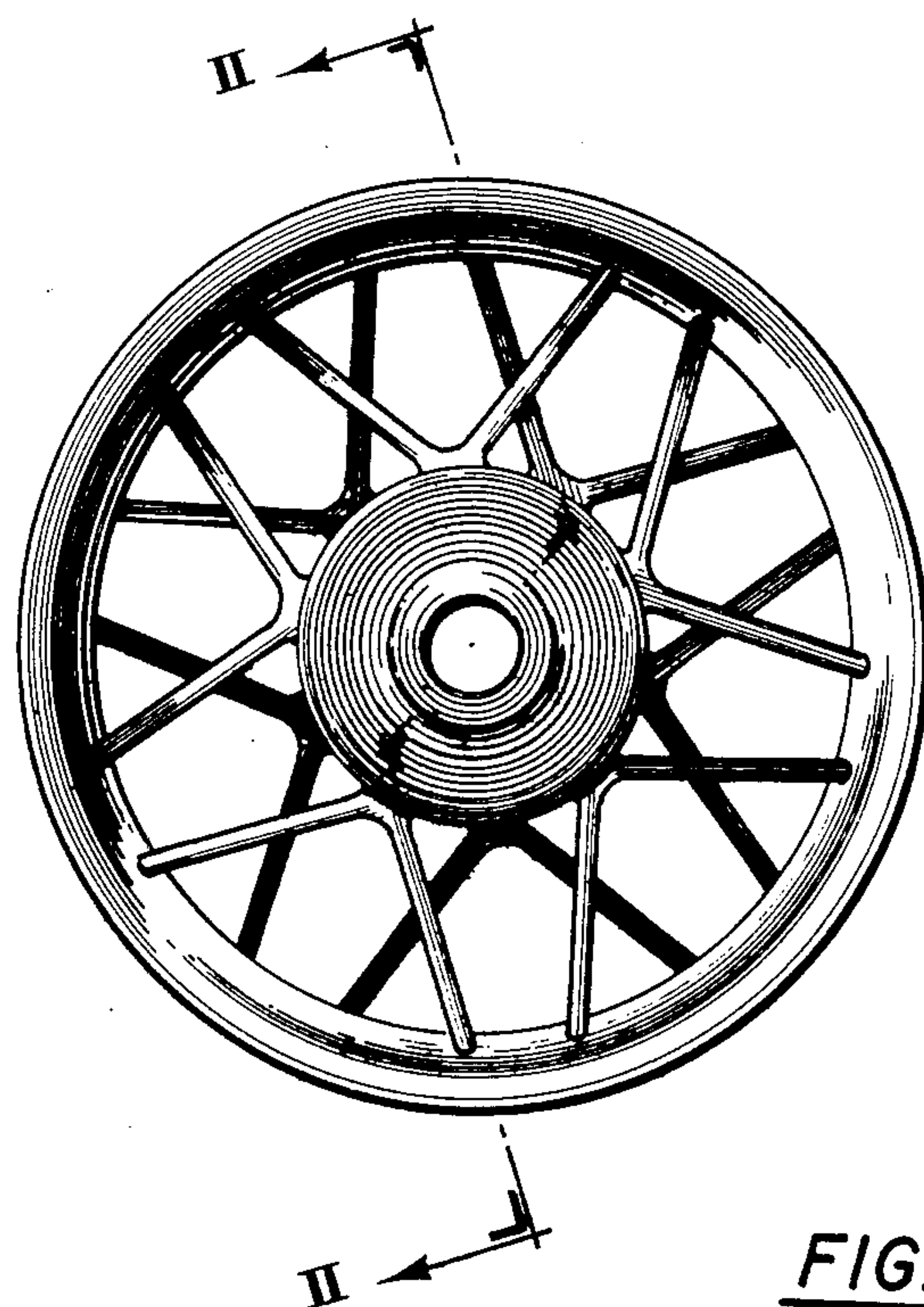

FIG. 1

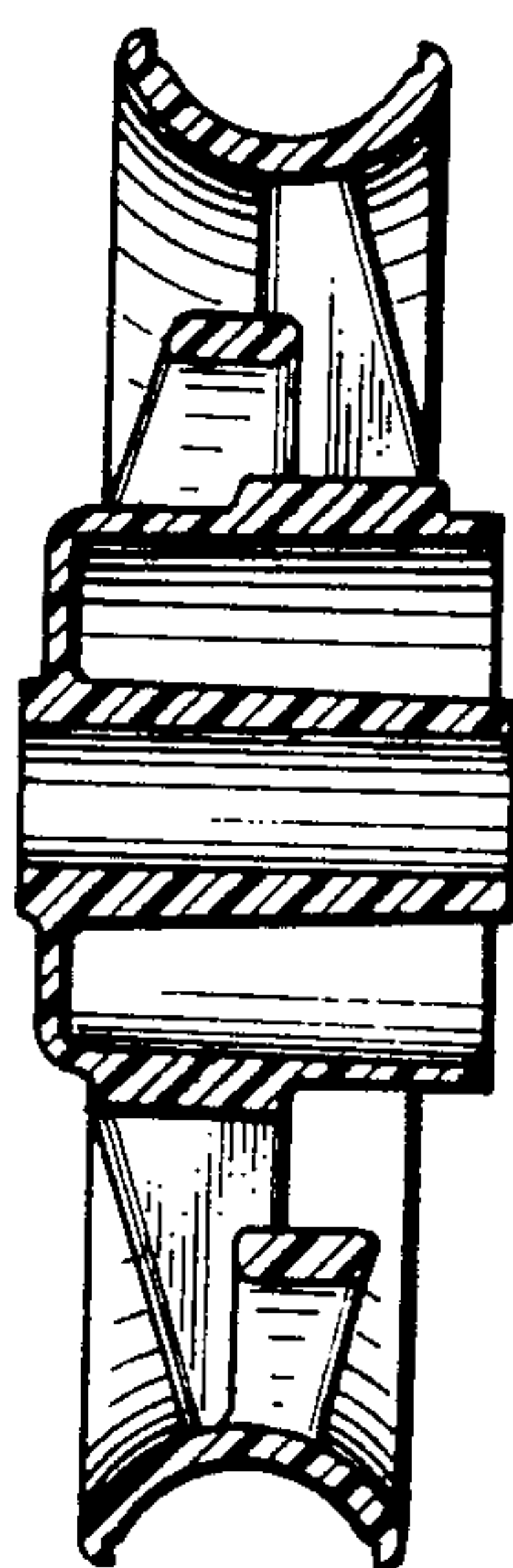

FIG. 2

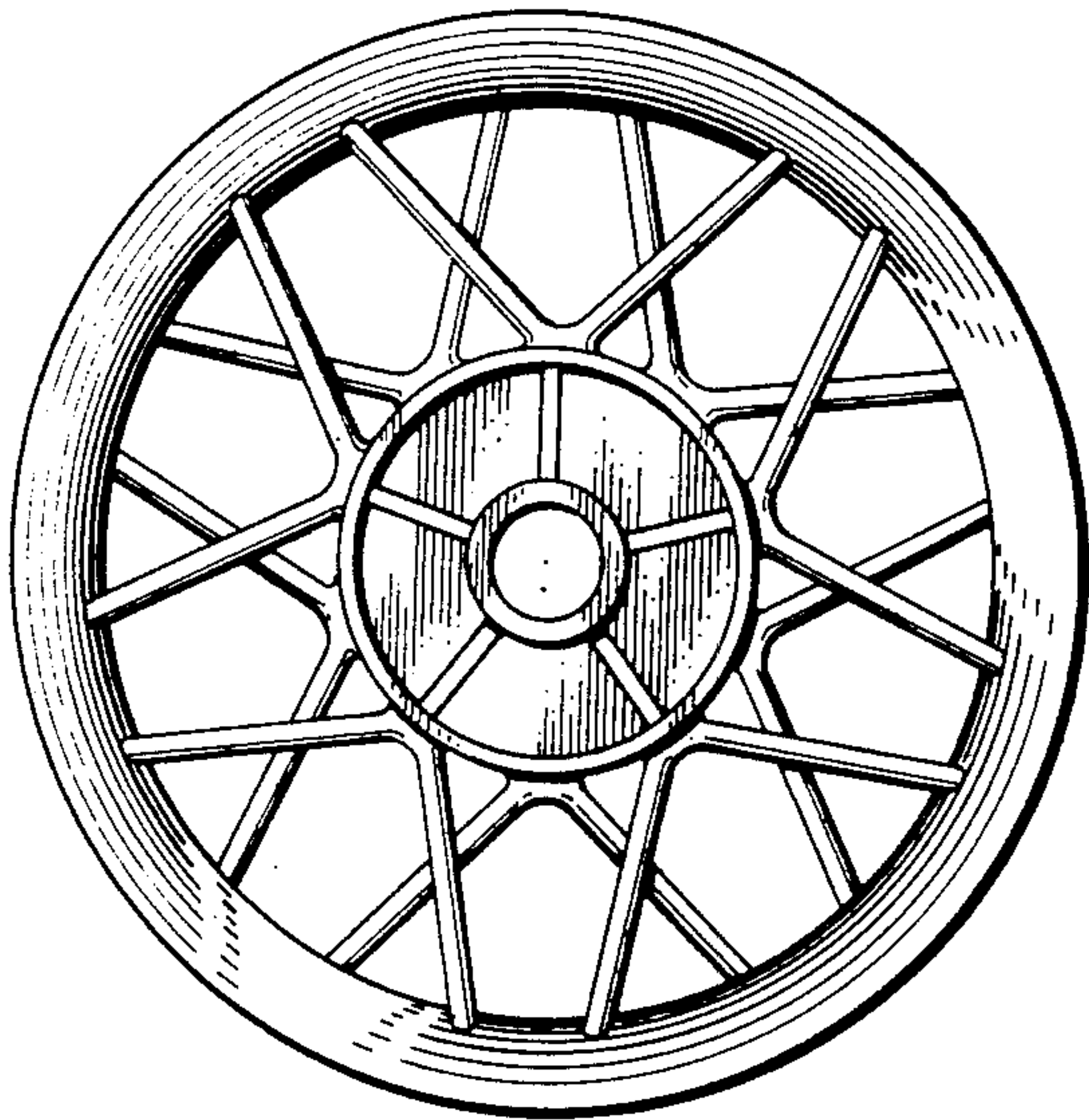

FIG. 3

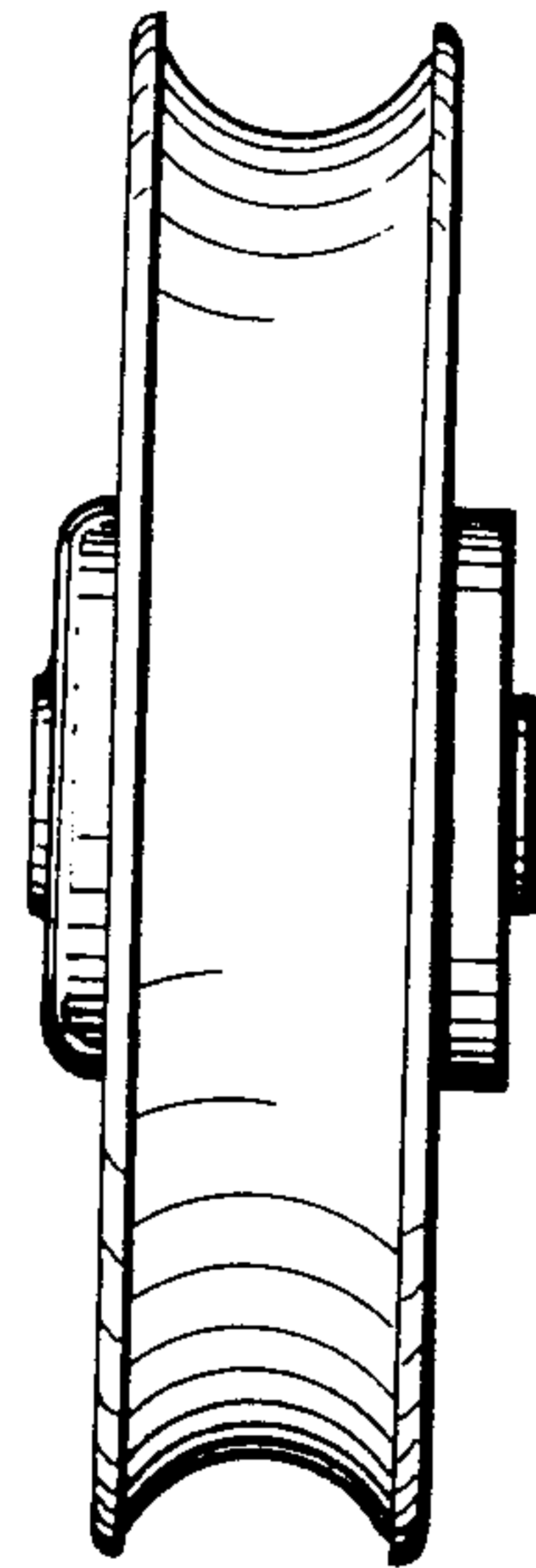

FIG. 4

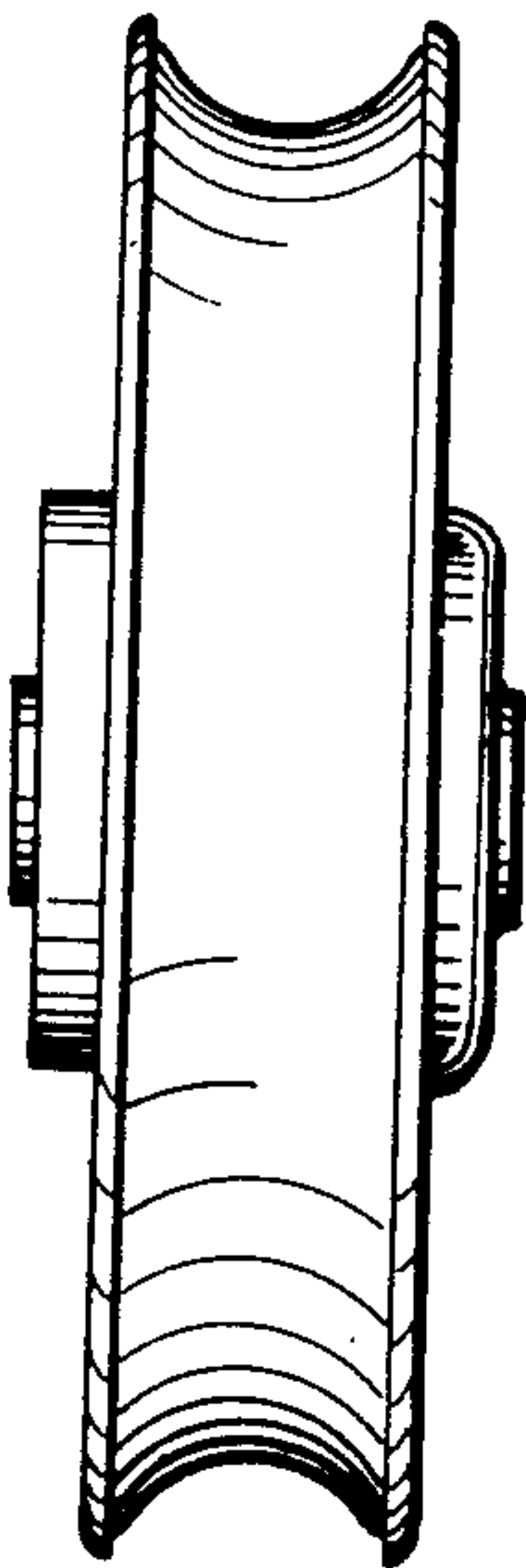

FIG. 5

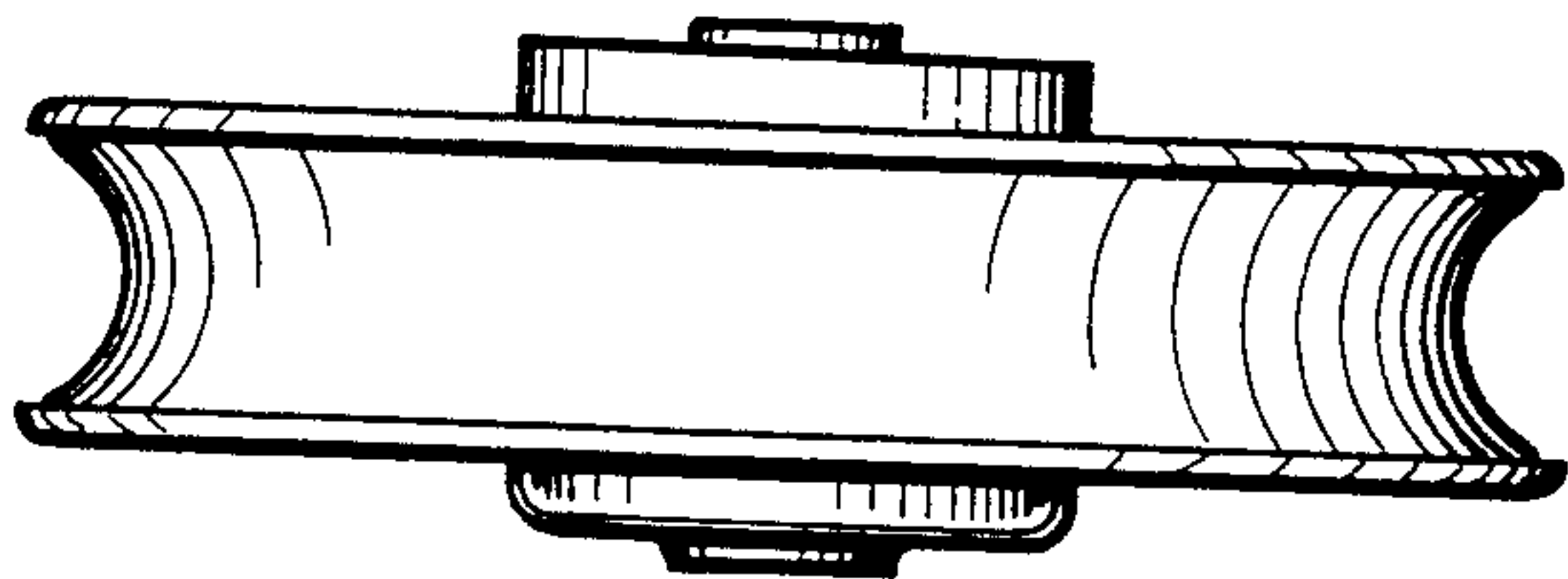

FIG. 6

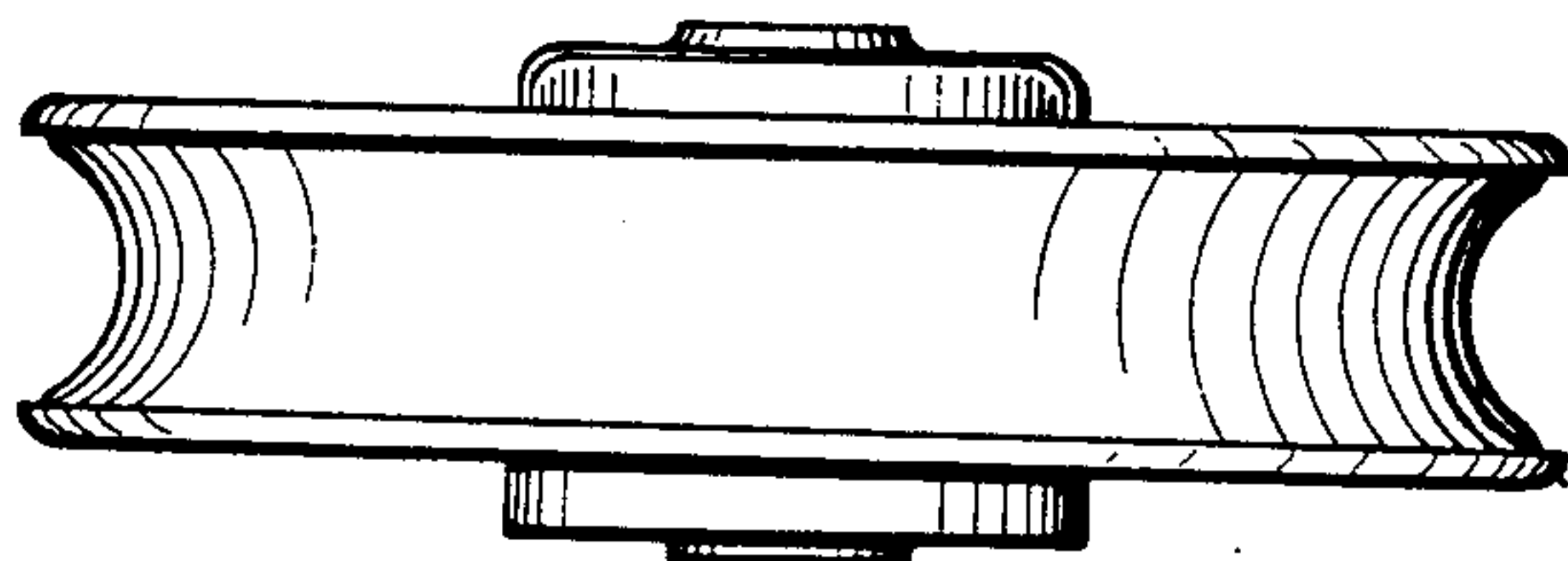

FIG. 7