

[54] TRACTOR CAB

[75] Inventors: Lee E. Elfes, Bloomfield Hills; Leo J. Lorenz, Farmington, both of Mich.

[73] Assignee: Massey-Ferguson Inc., Detroit, Mich.

[**] Term: 14 Years

[21] Appl. No.: 763,377

[22] Filed: Jan. 28, 1977

Related U.S. Application Data

[63] Continuation-in-part of Ser. No. 659,067, Feb. 18, 1976, abandoned.

[51] Int. Cl. D15-03

[52] U.S. Cl. D15/30

[58] Field of Search D15/30, 23, 24; D12/61; 180/89.1, 89.12, 89.13, 89.16, 89.18, 89.19; 296/28 C

[56] References Cited

U.S. PATENT DOCUMENTS

D. 225,521 12/1972 Lorenz et al. D15/23
3,397,008 8/1968 Timmerman 296/28 C

OTHER PUBLICATIONS

Implement & Tractor 2/7/75, front cover, Tractor, bottom center of page.

Implement & Tractor 12/15/72, p. 48, Tractor, top of page.

Agricultural Machinery Journal, 5/75, p. 64, Tractor Cab, top right side of page.

Agricultural Machinery Journal, 1/72, p. 22, Tractor Cab, bottom right side of page.

Primary Examiner—Wallace R. Burke

Assistant Examiner—James M. Gandy

Attorney, Agent, or Firm—John C. Thompson

[57] CLAIM

The ornamental design for the tractor cab, substantially as shown and described.

DESCRIPTION

FIG. 1 is an elevational view of the tractor cab embodying our new design and taken from the left side thereof; FIG. 2 is an elevational view taken from the front thereof;

FIG. 3 is an elevational view taken from the right side thereof;

FIG. 4 is an elevational view taken from the rear thereof; and

FIG. 5 is a top plan view thereof.

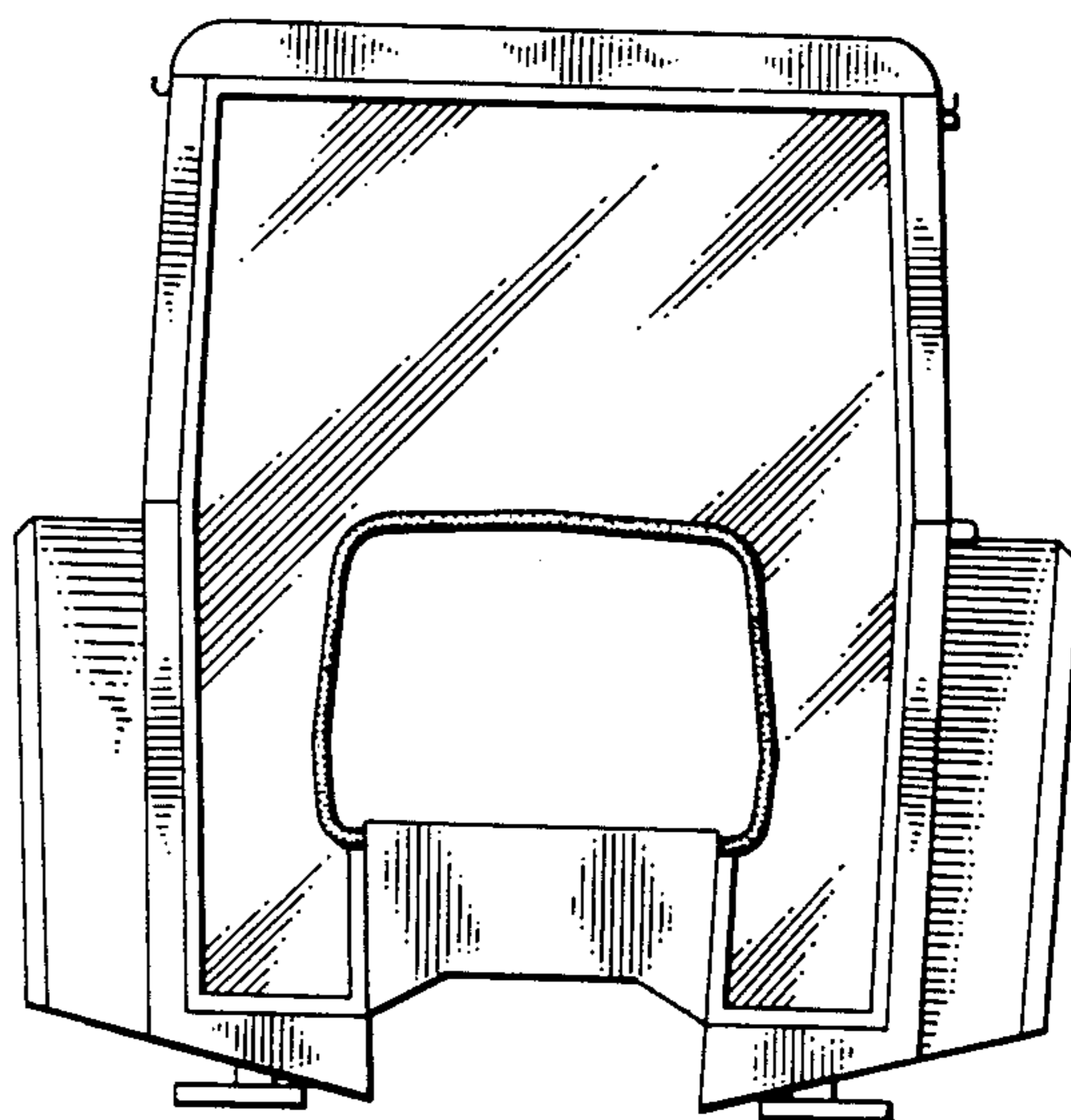
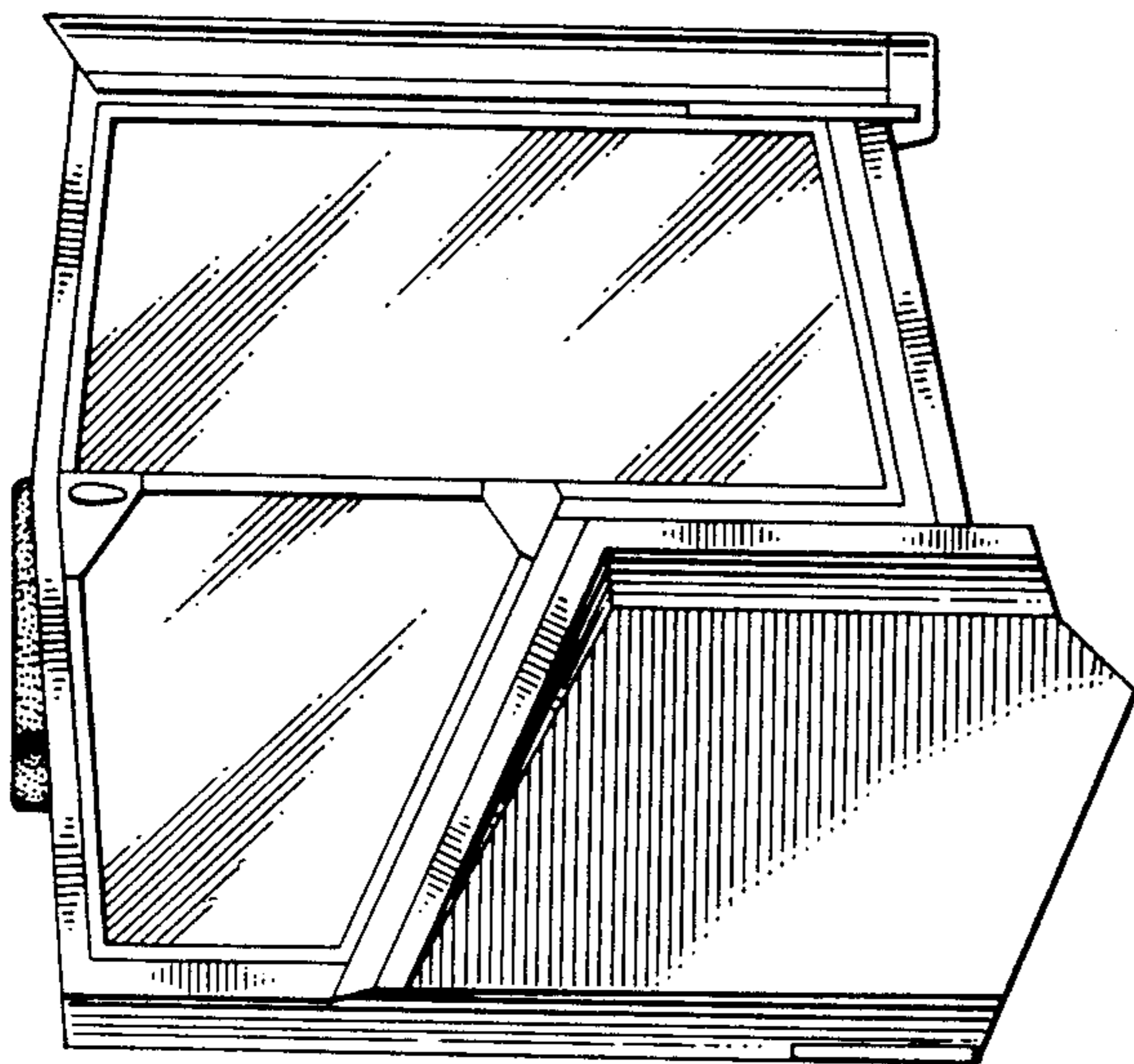

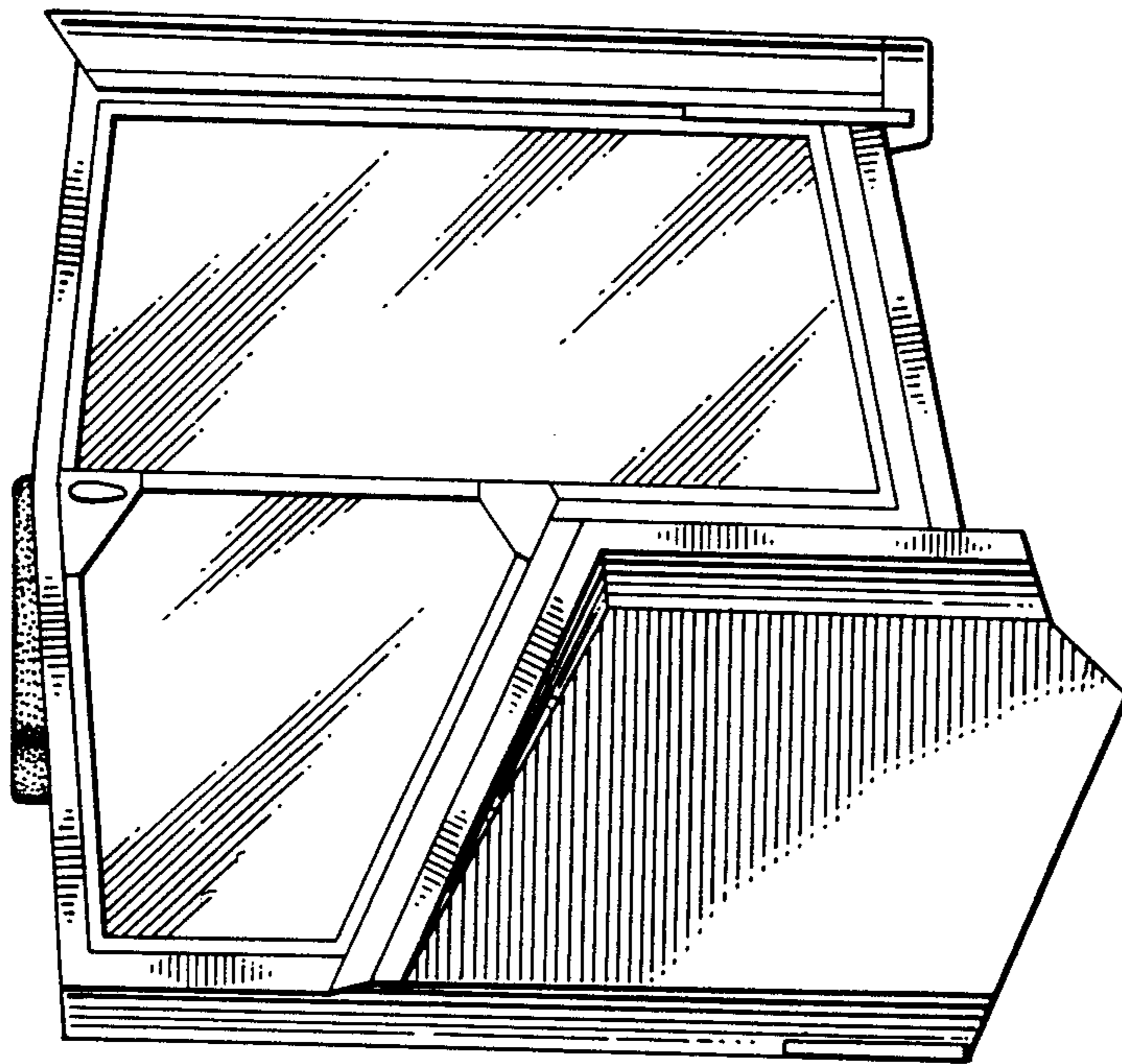

Fig. 1

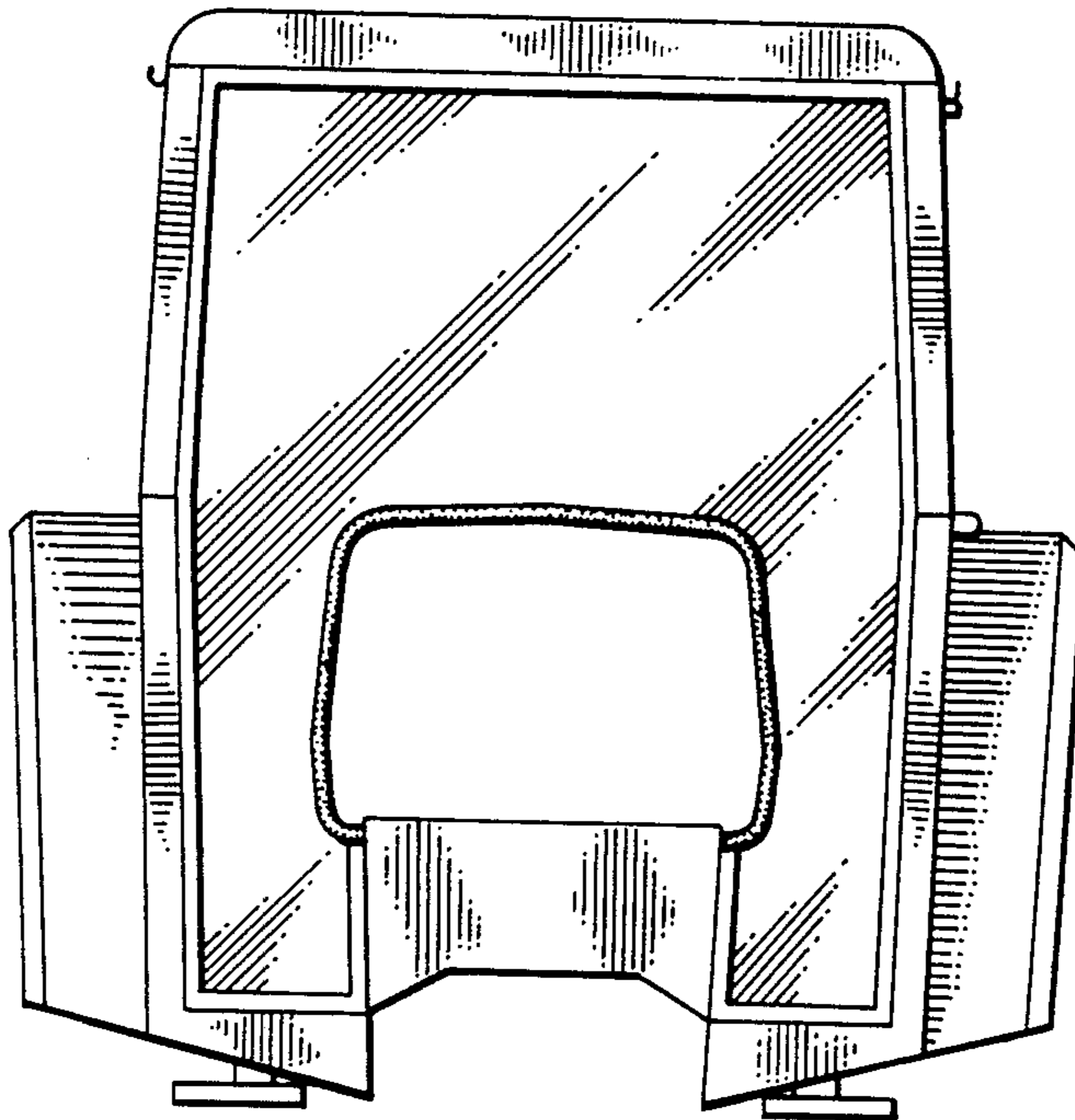

Fig. 2

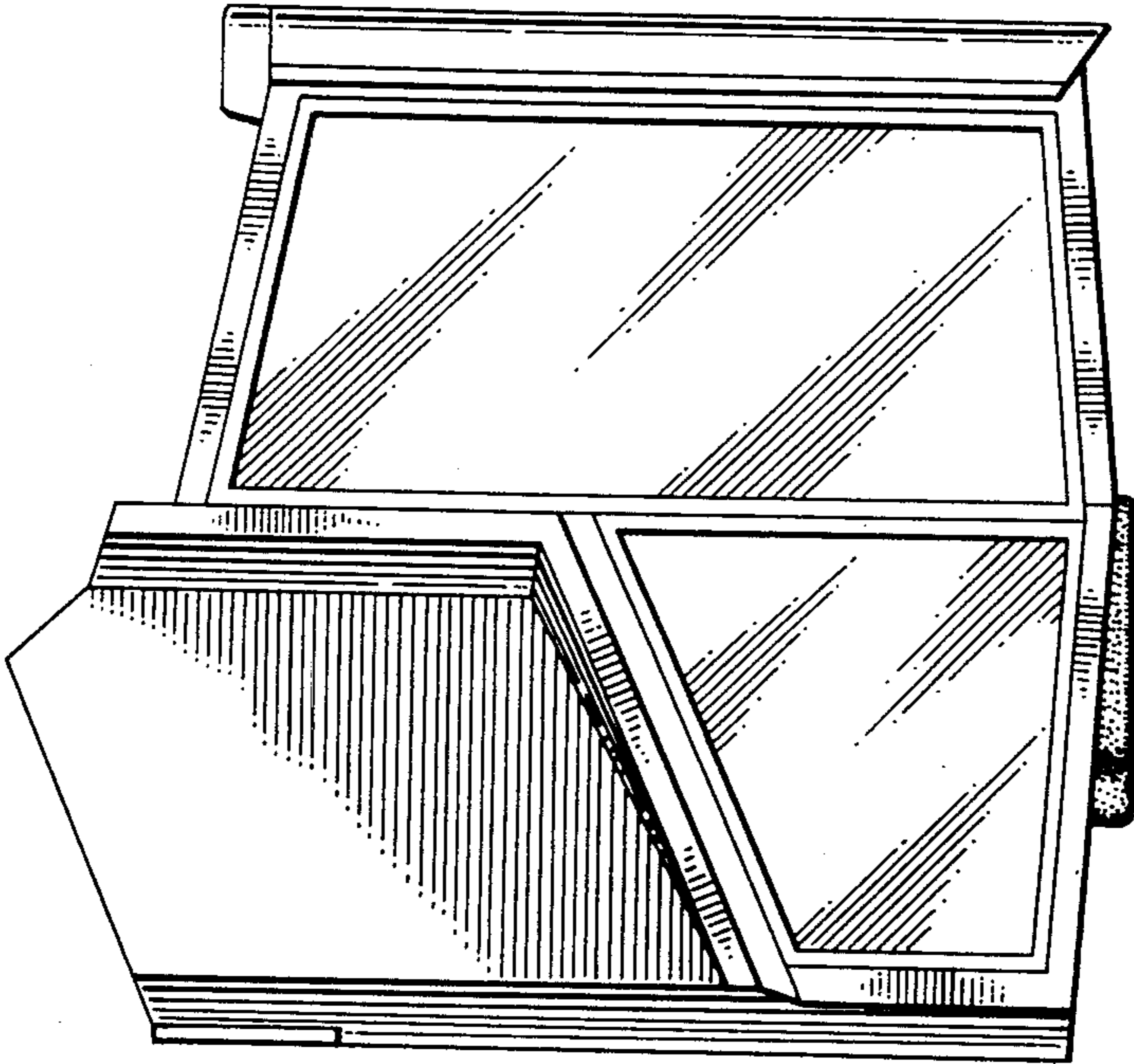

Fig. 3

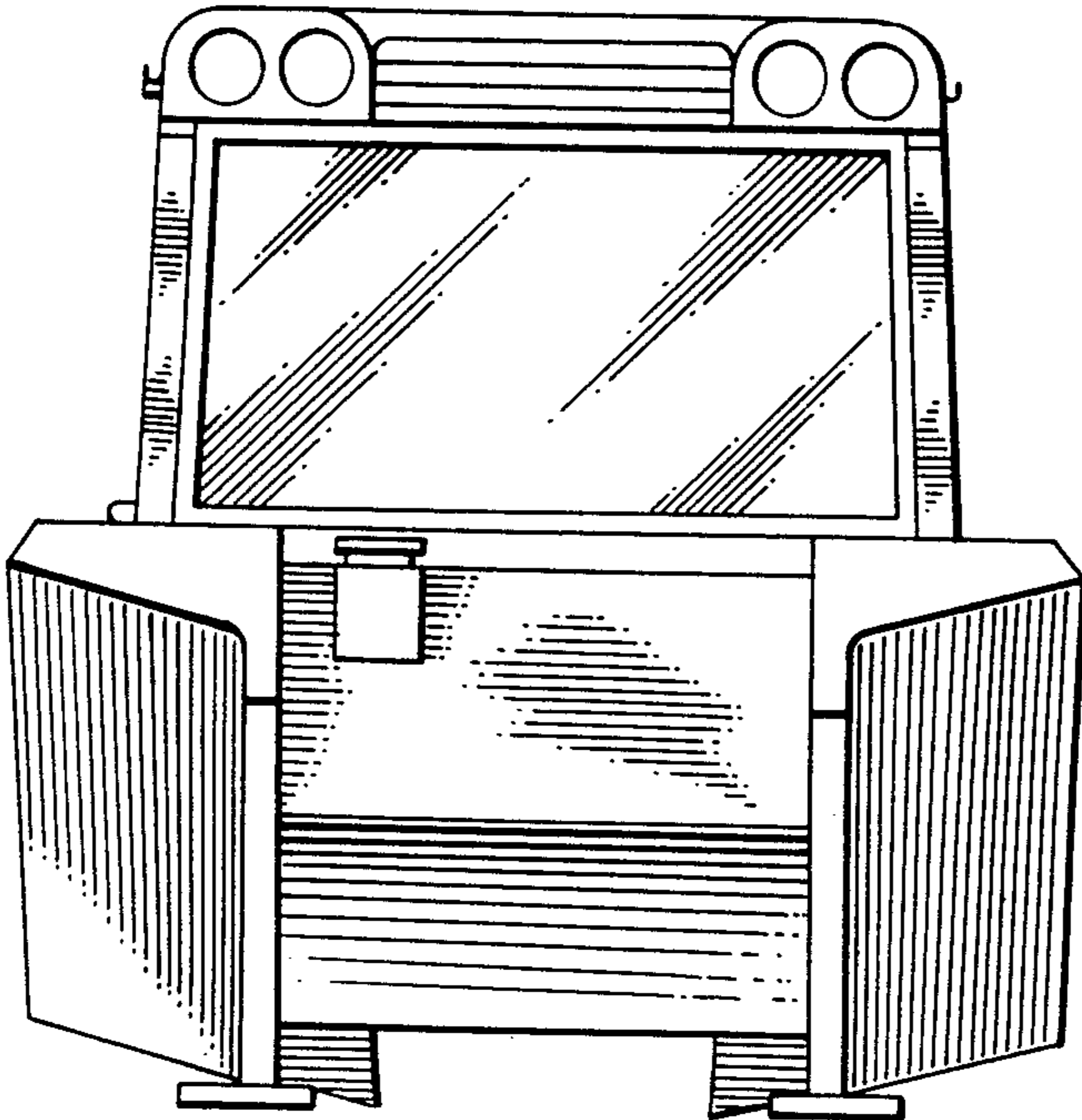

Fig. 4

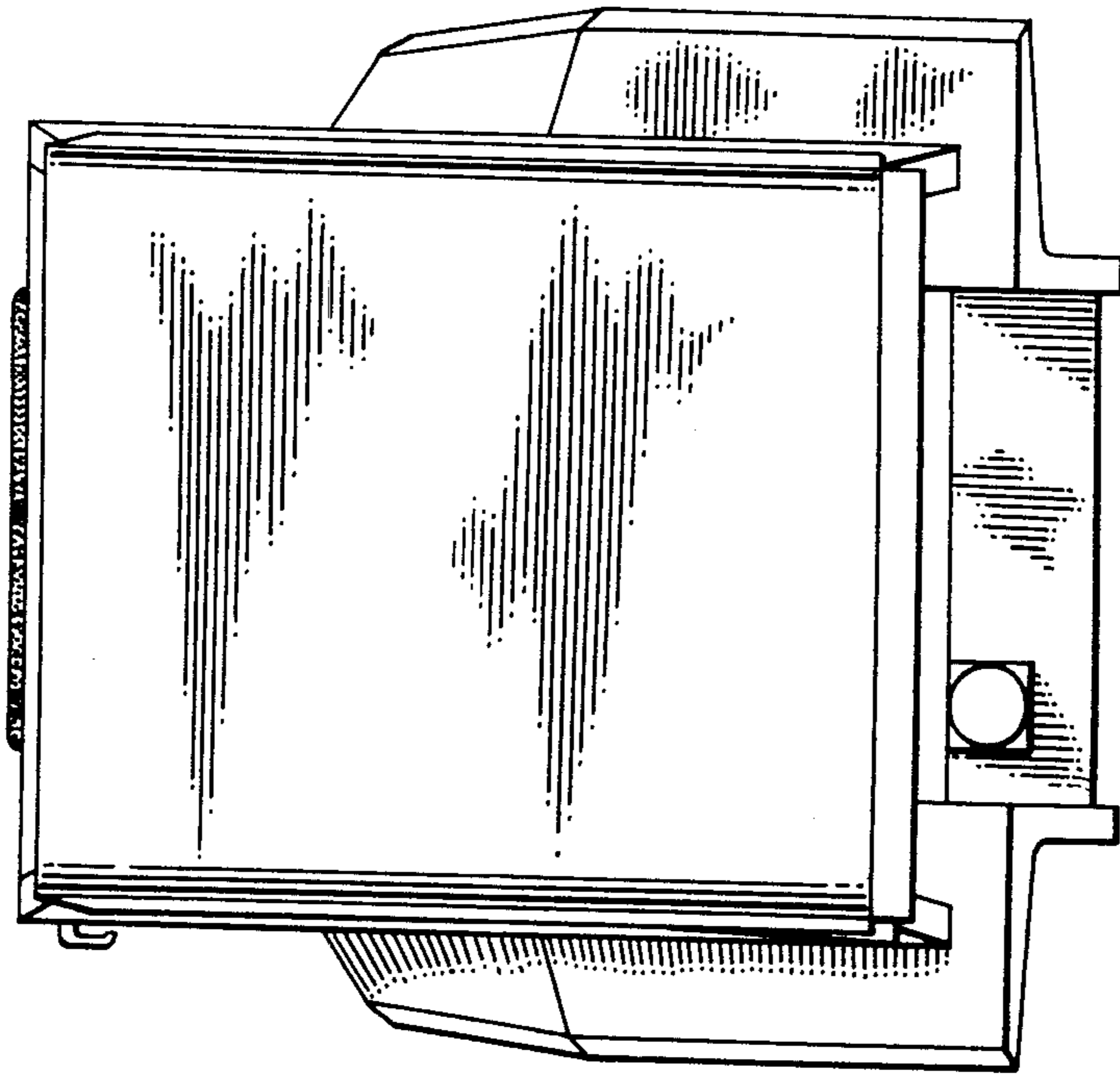

Fig. 5