

[54] HULL FOR A SAILBOAT

[75] Inventor: **Richard Lynn Rineman**, 4644 Mount Brighton Ave., Brighton, Mich. 48116

[73] Assignees: **Harold J. Rineman; Richard Lynn Rineman; S. Albert Young; Benjamin W. Colman**, ; part interest to each

[\*] Notice: The portion of the term of this patent subsequent to Dec. 7, 1990, has been disclaimed.

[\*\*] Term: **14 Years**

[21] Appl. No.: **721,132**

[22] Filed: **Sep. 7, 1976**

**Related U.S. Application Data**

[63] Continuation-in-part of Ser. No. 629,689, Nov. 6, 1975, Pat. No. D. 242,614.

[51] Int. Cl. .... **D12-06**

[52] U.S. Cl. .... **D12/64**

[58] Field of Search ..... **D12/64, 62; 114/39**

**References Cited**

**U.S. PATENT DOCUMENTS**

D. 242,614	12/1976	Rineman .....	D12/64
3,173,395	3/1965	Laurent .....	114/39
3,487,800	1/1970	Schweitzer et al. ....	114/39
3,762,353	10/1973	Shutt .....	114/39
3,870,004	3/1975	Bailey .....	114/39

Primary Examiner—Alan P. Douglas  
Attorney, Agent, or Firm—Benjamin W. Colman

[57] **CLAIM**

The ornamental design for a hull for a sailboat, as shown and described.

**DESCRIPTION**

FIG. 1 is a perspective view of the hull for a sailboat, showing my new design.

FIG. 2 is an end elevational view, taken substantially on the line 2-2 in the direction of the arrows, of the view illustrated in FIG. 1.

FIGS. 3 and 4 are side elevational views, taken substantially on the lines 3-3 and 4-4 of the view illustrated in FIG. 1.

FIG. 5 is a top plan view of the hull for a sailboat illustrated in FIG. 1.

FIGS. 6, 7 and 8 are transverse vertical sectional views taken substantially on the lines 6-6, 7-7 and 8-8 respectively of the view illustrated in FIG. 5.

FIG. 9 is a fragmentary perspective view of a portion of a modified form of the hull shown in FIG. 1, in which the only difference thereover is shown.

FIG. 10 is a fragmentary plan view of the portion of the hull illustrated in FIG. 9.

FIG. 11 is a fragmentary perspective view of a portion of a second modified form of the hull shown in FIG. 1, in which the only difference thereover is shown.

FIG. 12 is a fragmentary perspective view of a portion of a third modified form of the hull shown in FIG. 1, in which the only difference thereover is shown.

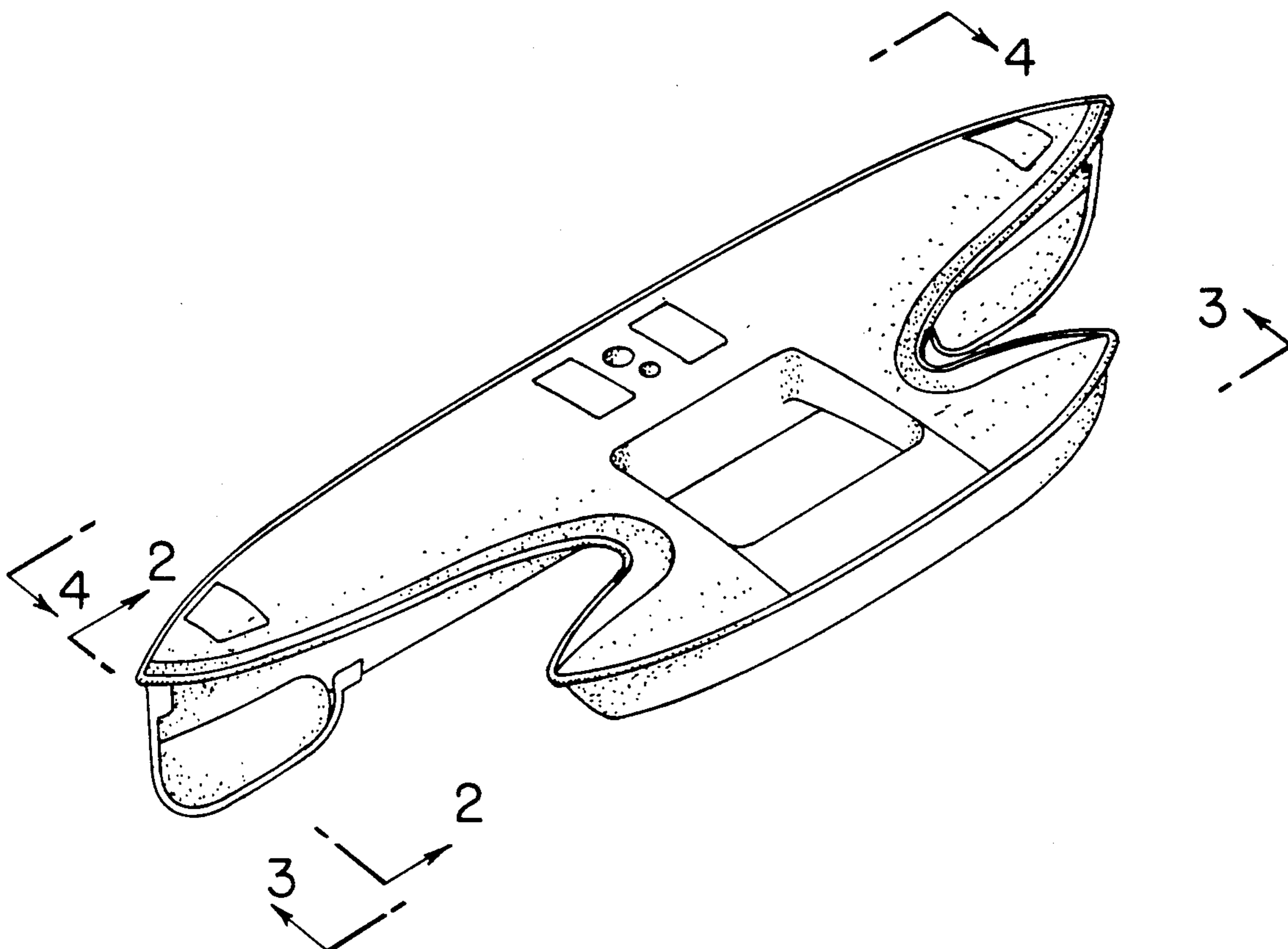

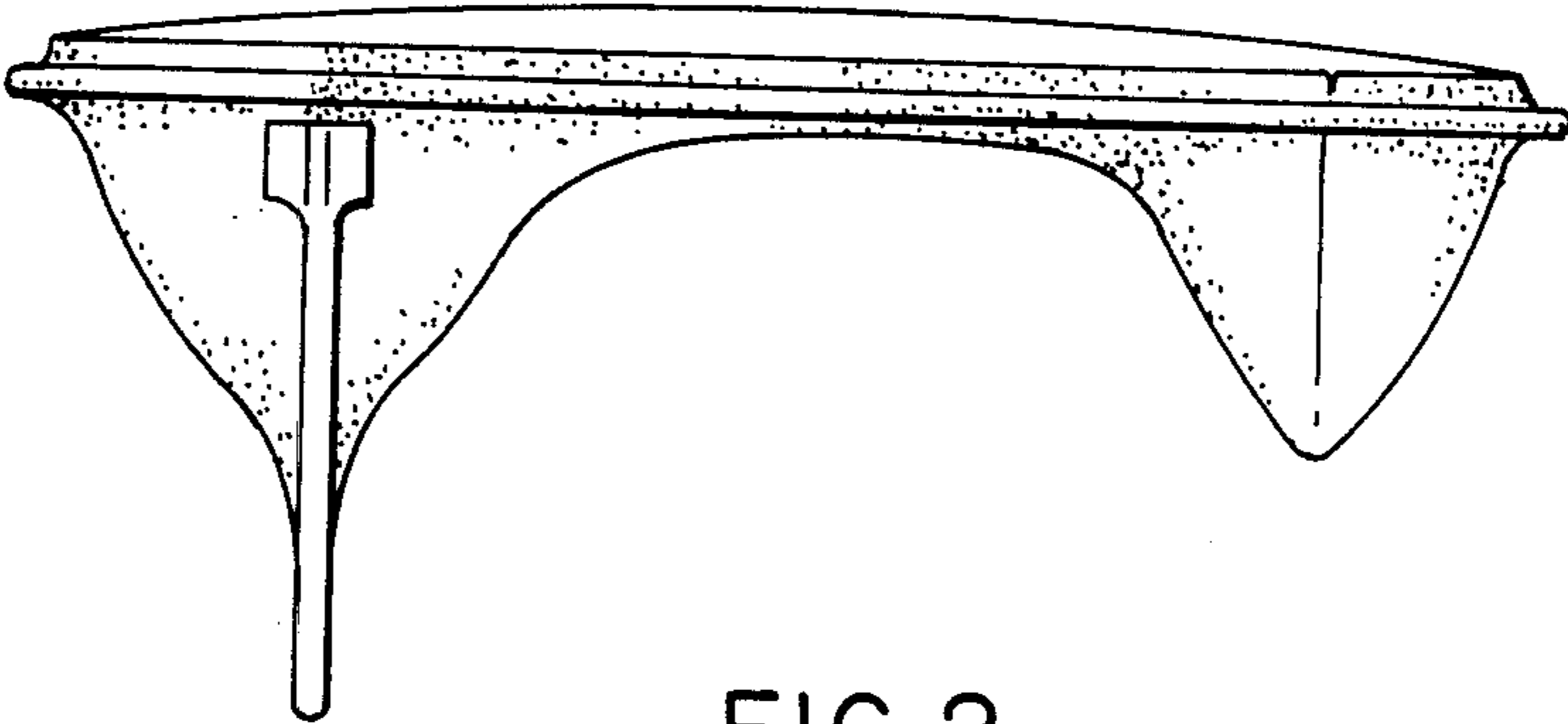
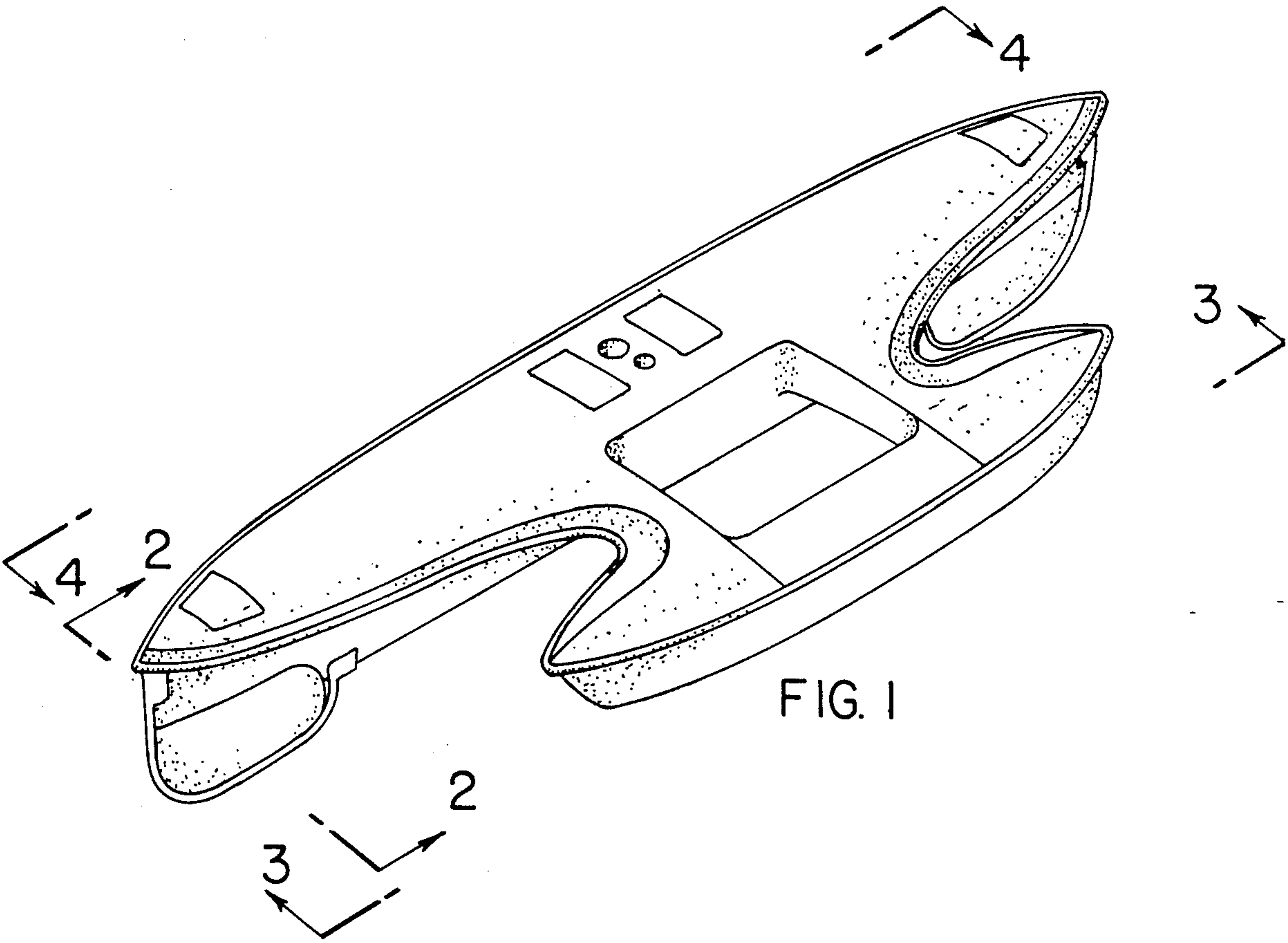

FIG. 2

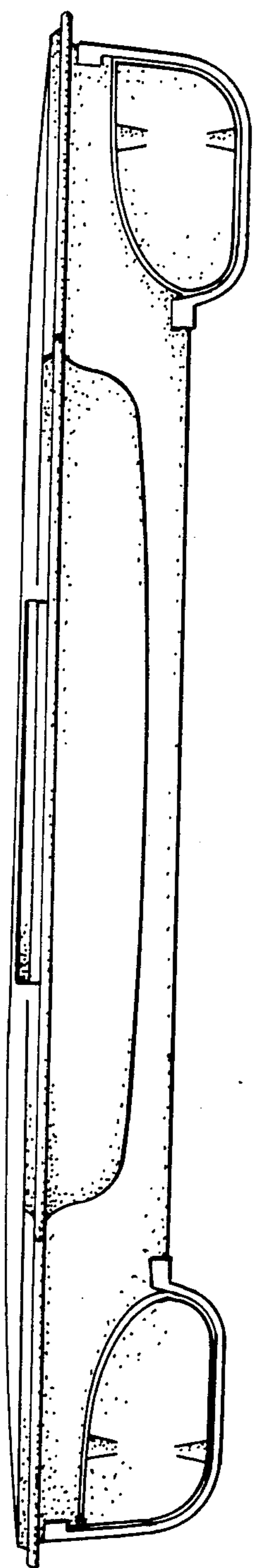

FIG. 3

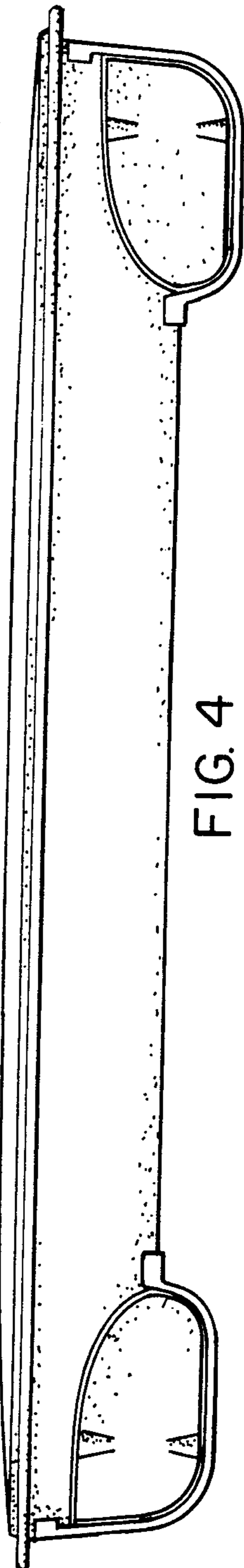

FIG. 4

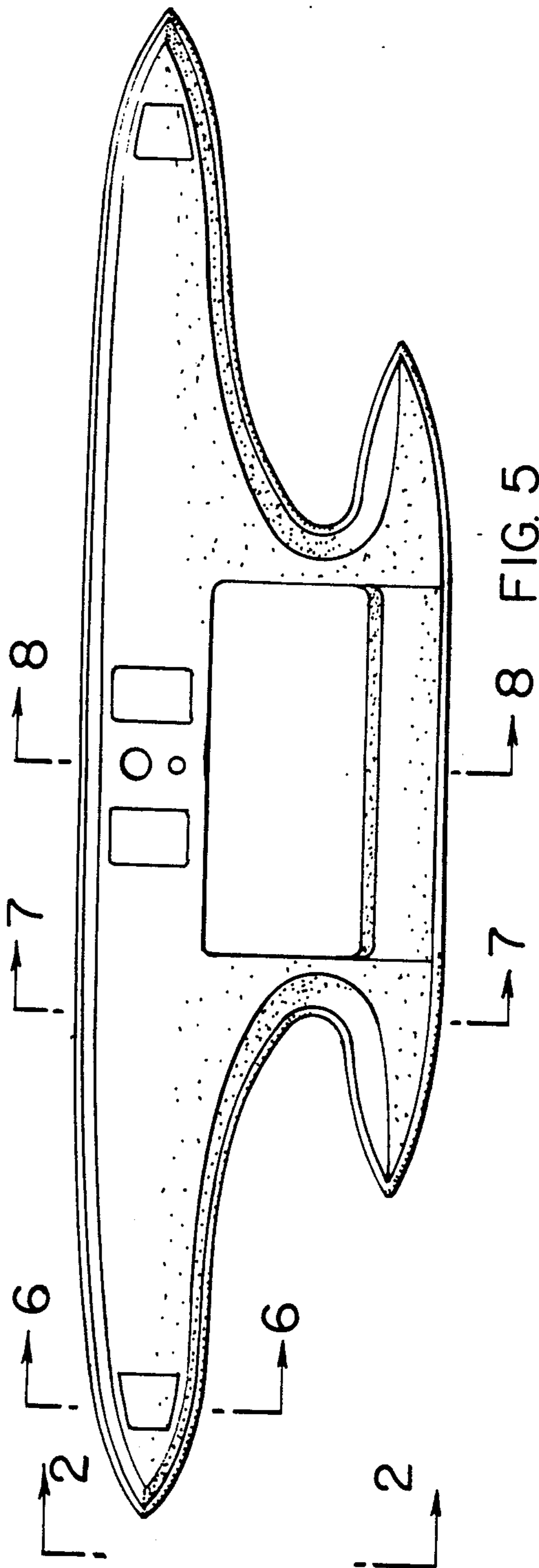

FIG. 5

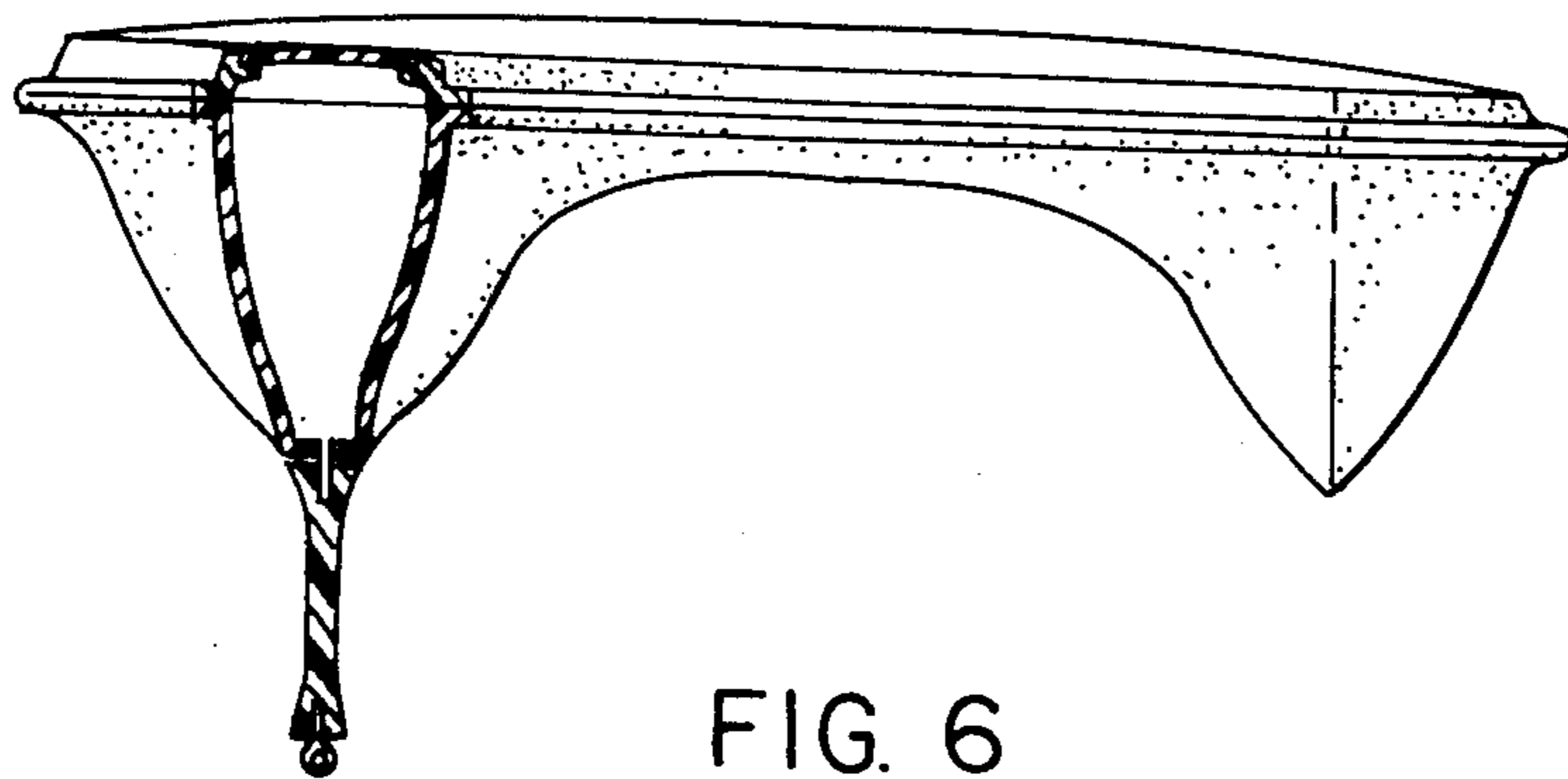

FIG. 6

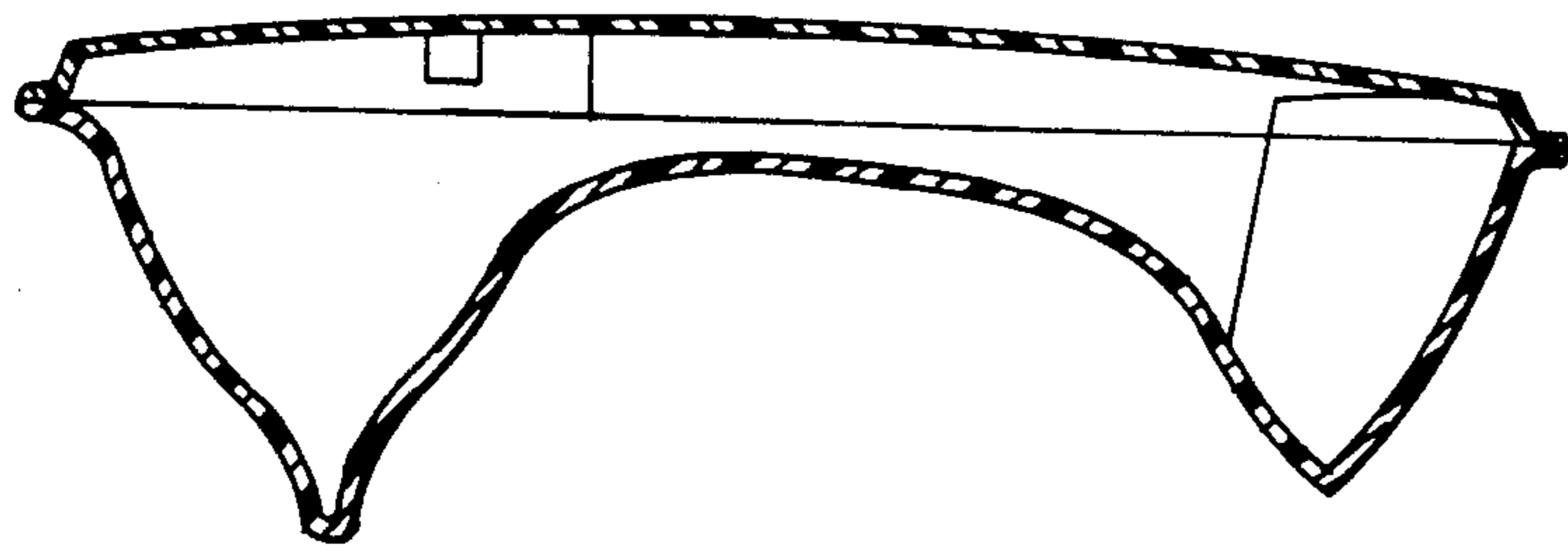

FIG. 7

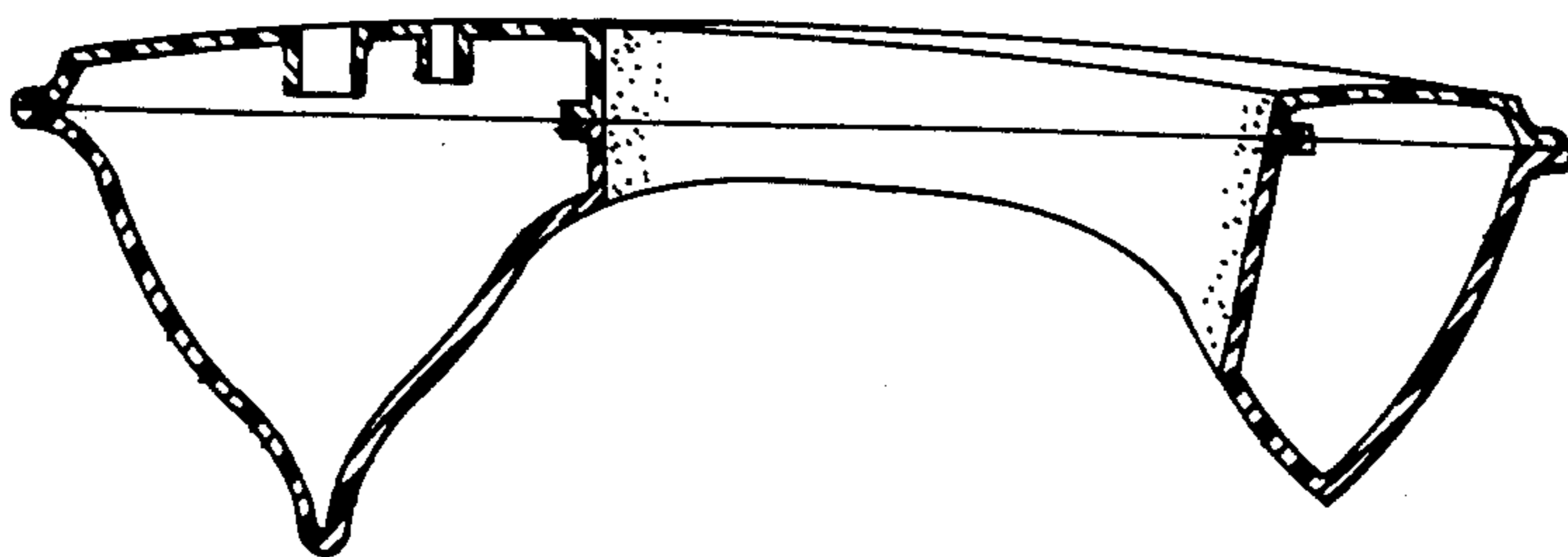

FIG. 8

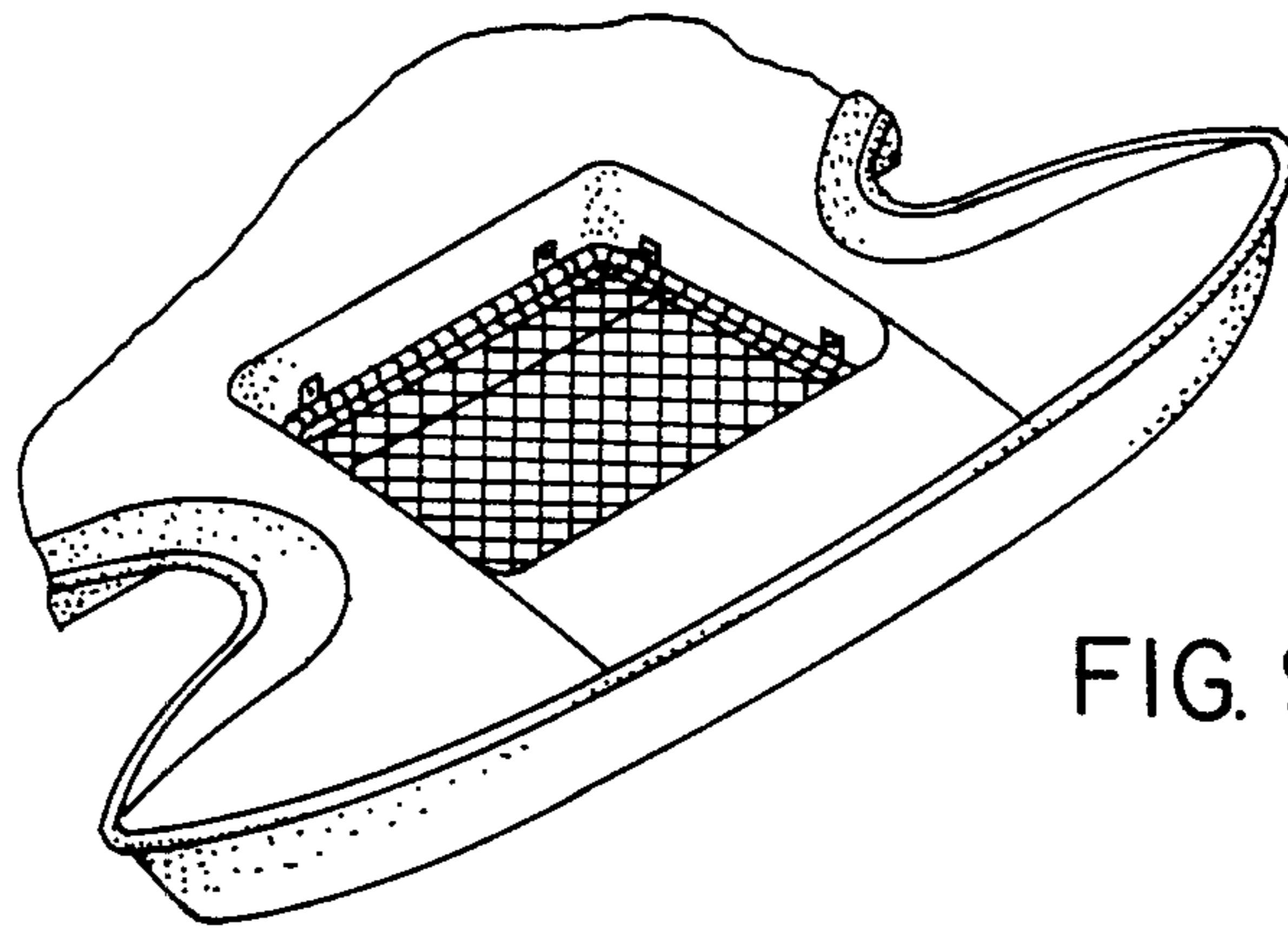

FIG. 9

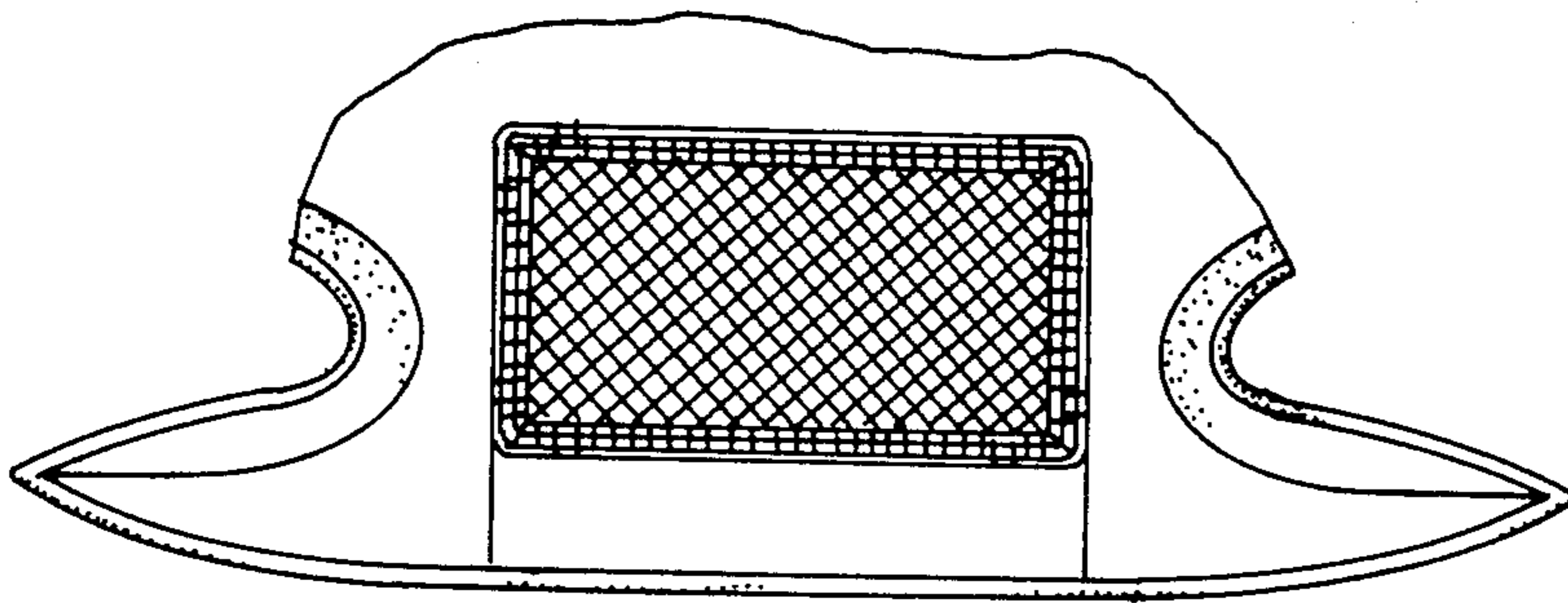

FIG. 10

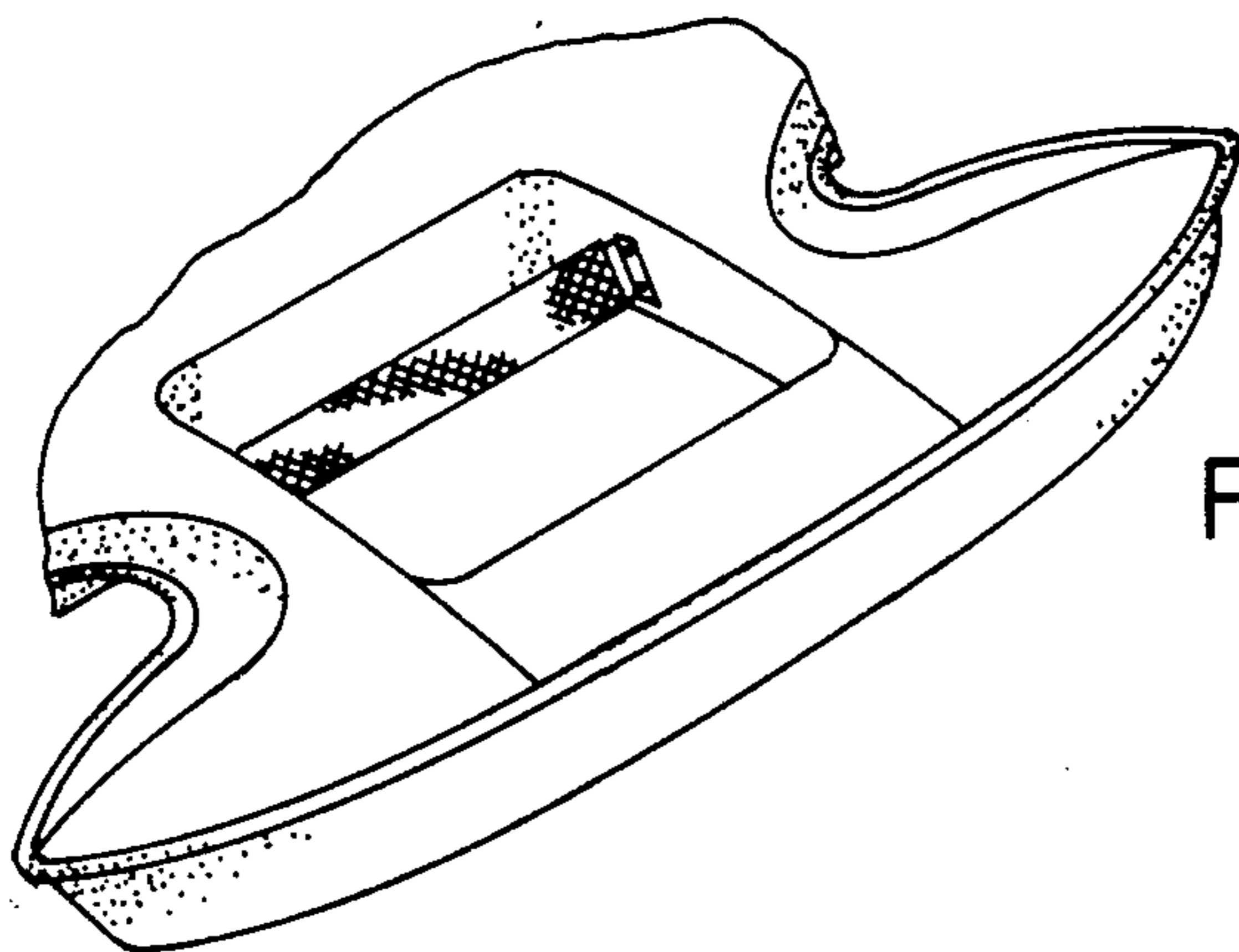

FIG. 11

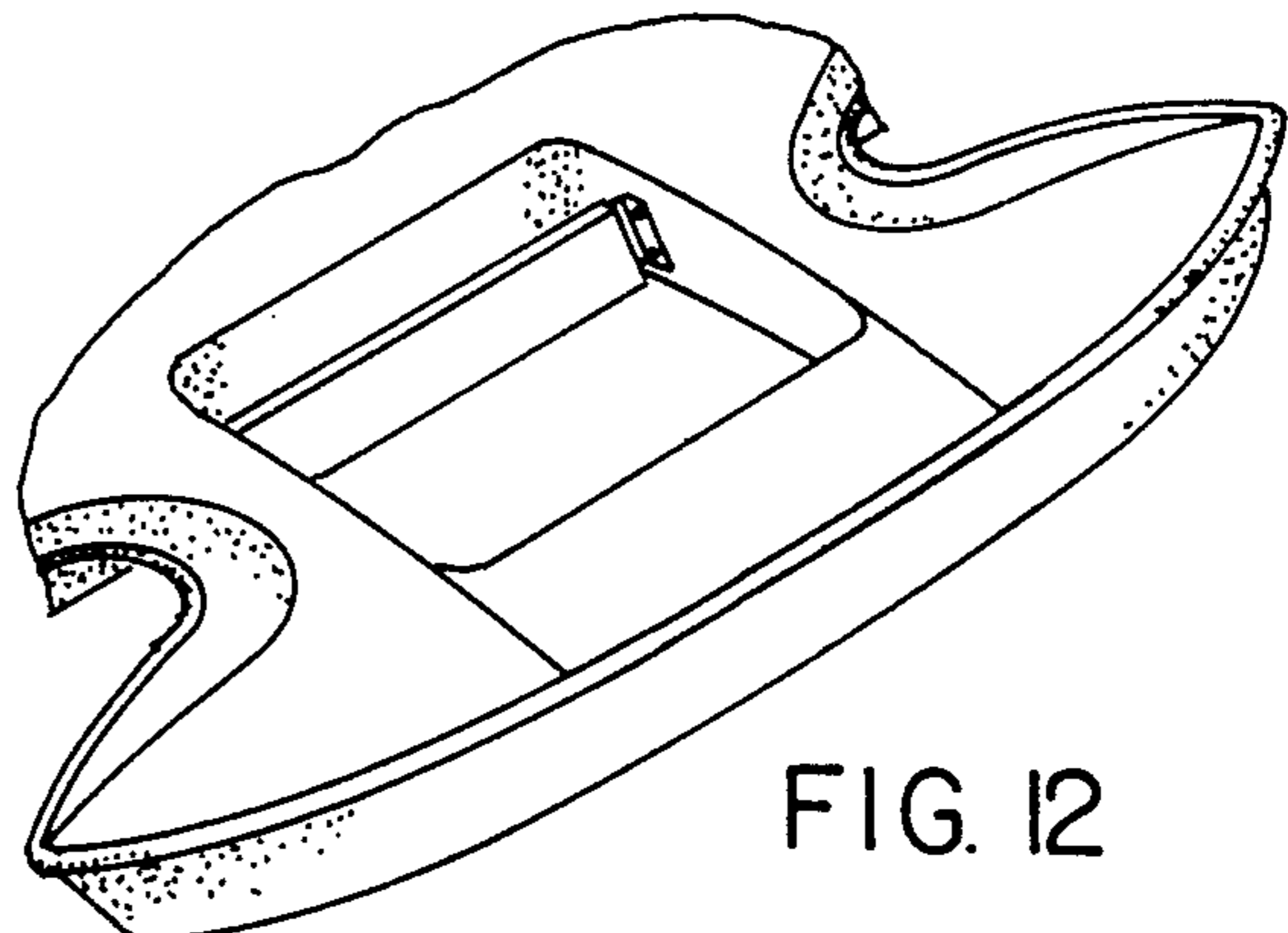

FIG. 12