

[54] COMBINED DUAL RAILROAD PASSENGER SEAT AND LEGRESTS

[75] Inventor: Robert J. Bengtsson, Colorado Springs, Colo.

[73] Assignee: AMI Industries Inc., Colorado Springs, Colo.

[**] Term: 14 Years

[21] Appl. No.: 713,125

[22] Filed: Aug. 10, 1976

[51] Int. Cl. D6-01

[52] U.S. Cl. D6/48

[58] Field of Search D6/37, 38, 39, 47, 48, D6/67; 297/232, 248, 249

[56] References Cited

U.S. PATENT DOCUMENTS

D. 138,511 8/1944 Dreyfuss D6/48
D. 184,656 3/1959 Baynes D6/48

D. 186,105 9/1959 Dietz et al. D6/48
D. 216,969 3/1970 Barecki D6/48
D. 233,921 12/1974 Barecki D6/48
D. 239,148 3/1976 Smith et al. D6/48

Primary Examiner—Bruce W. Dunkins
Attorney, Agent, or Firm—W. Britton Moore

[57] CLAIM

The ornamental design for a combined dual railroad passenger seat and legrests, substantially as shown and described.

DESCRIPTION

FIG. 1 is a front elevation of my new design for a combined dual railroad passenger seat and legrests; FIG. 2 is a top plan view thereof; FIG. 3 is a side view, with the food trays and legrests in operative positions, and the side of the seat not shown herein is a mirror image of the side shown. FIG. 4 is a rear view thereof; and FIG. 5 is a perspective view, showing the food trays in closed positions, and the legrests in operative positions.

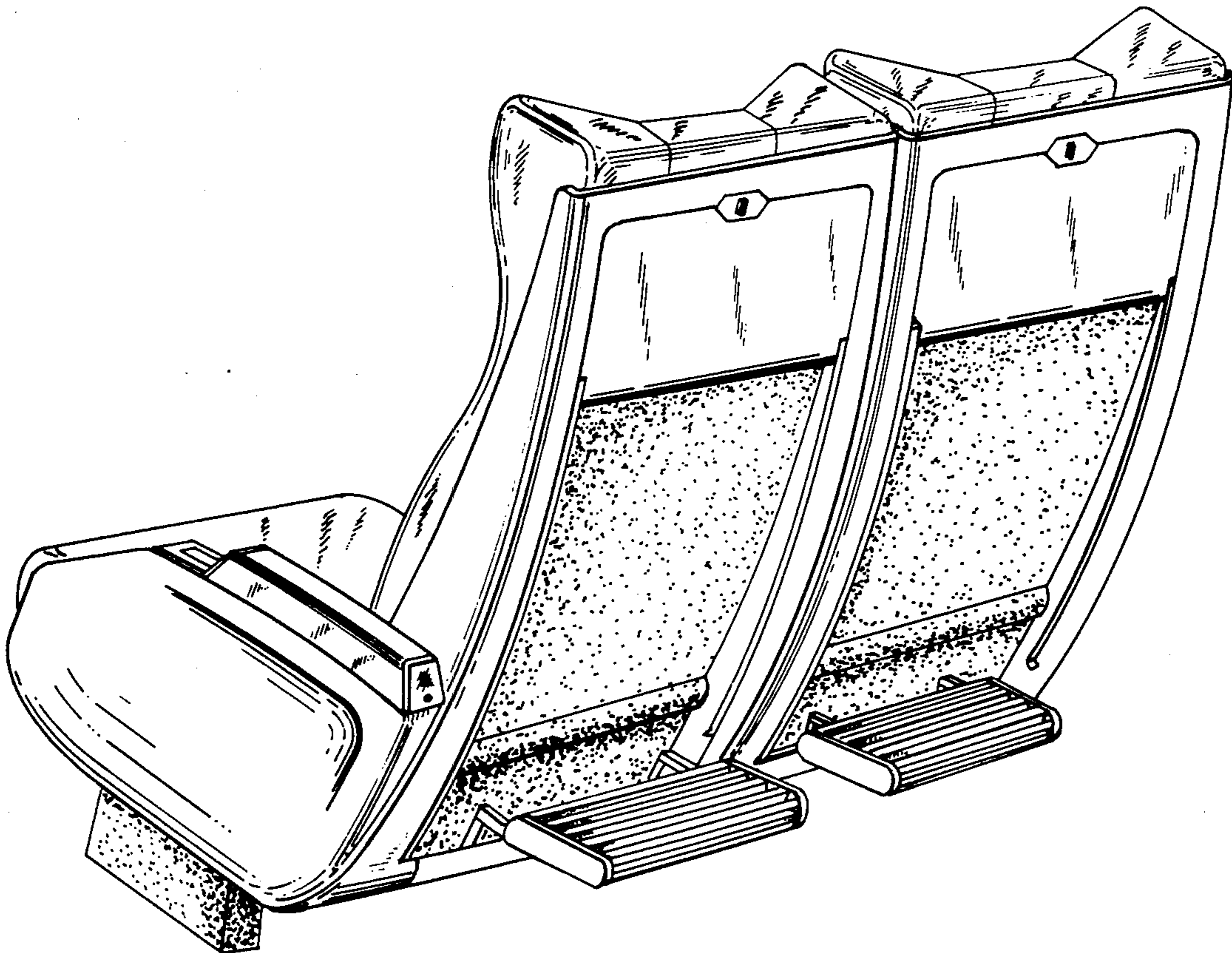

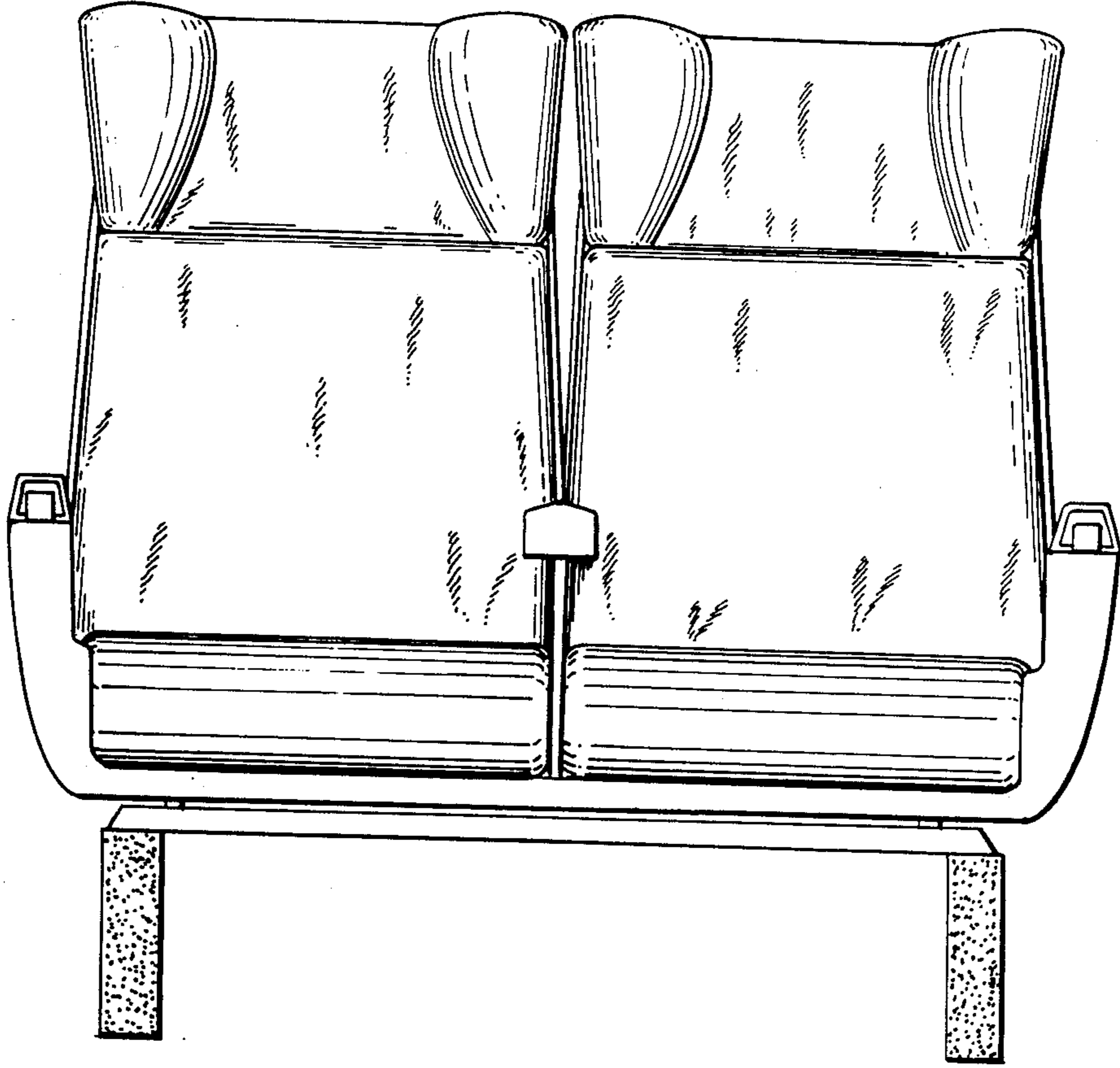

FIG. 1

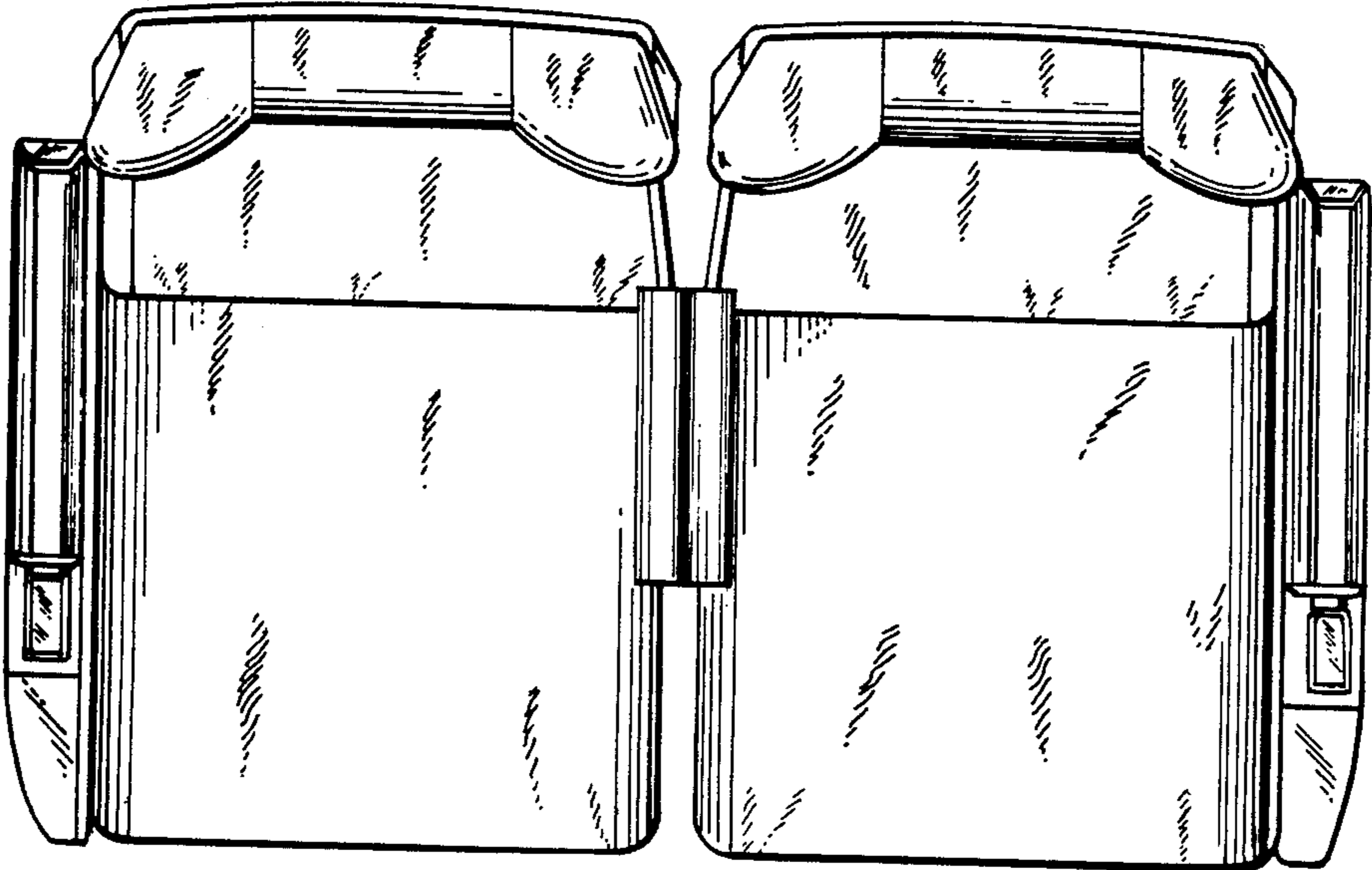

FIG. 2

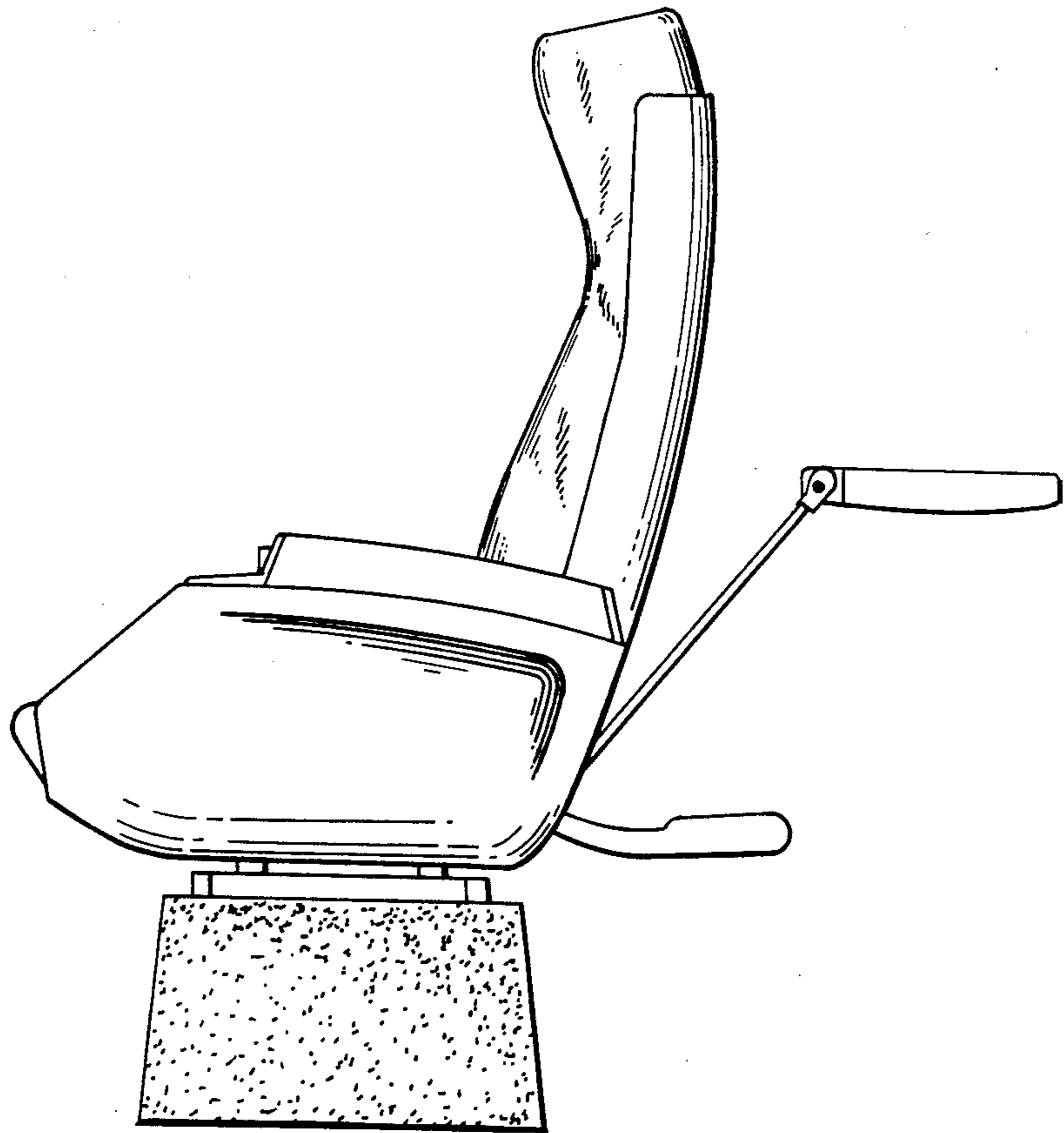

FIG. 3

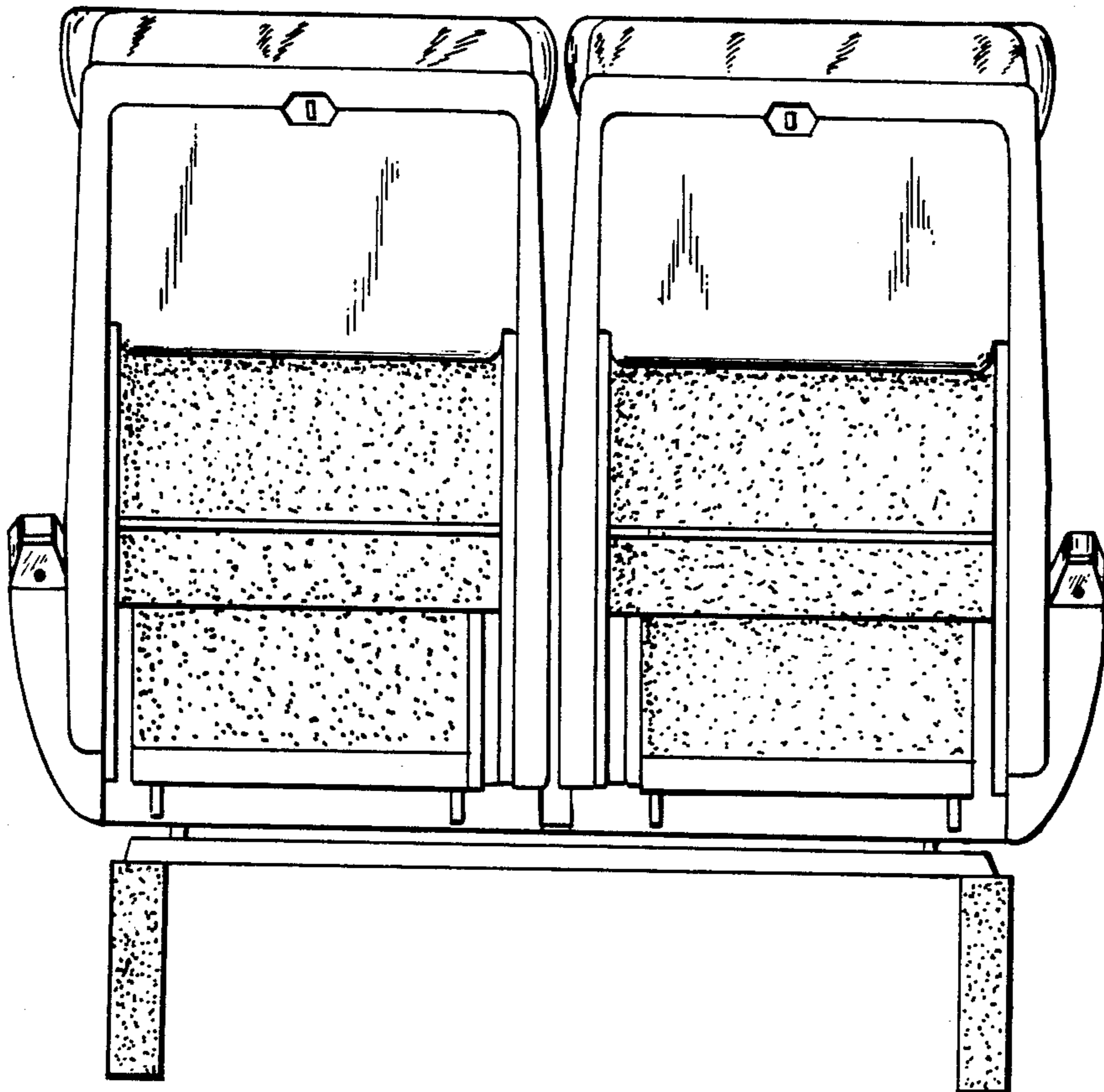

FIG. 4

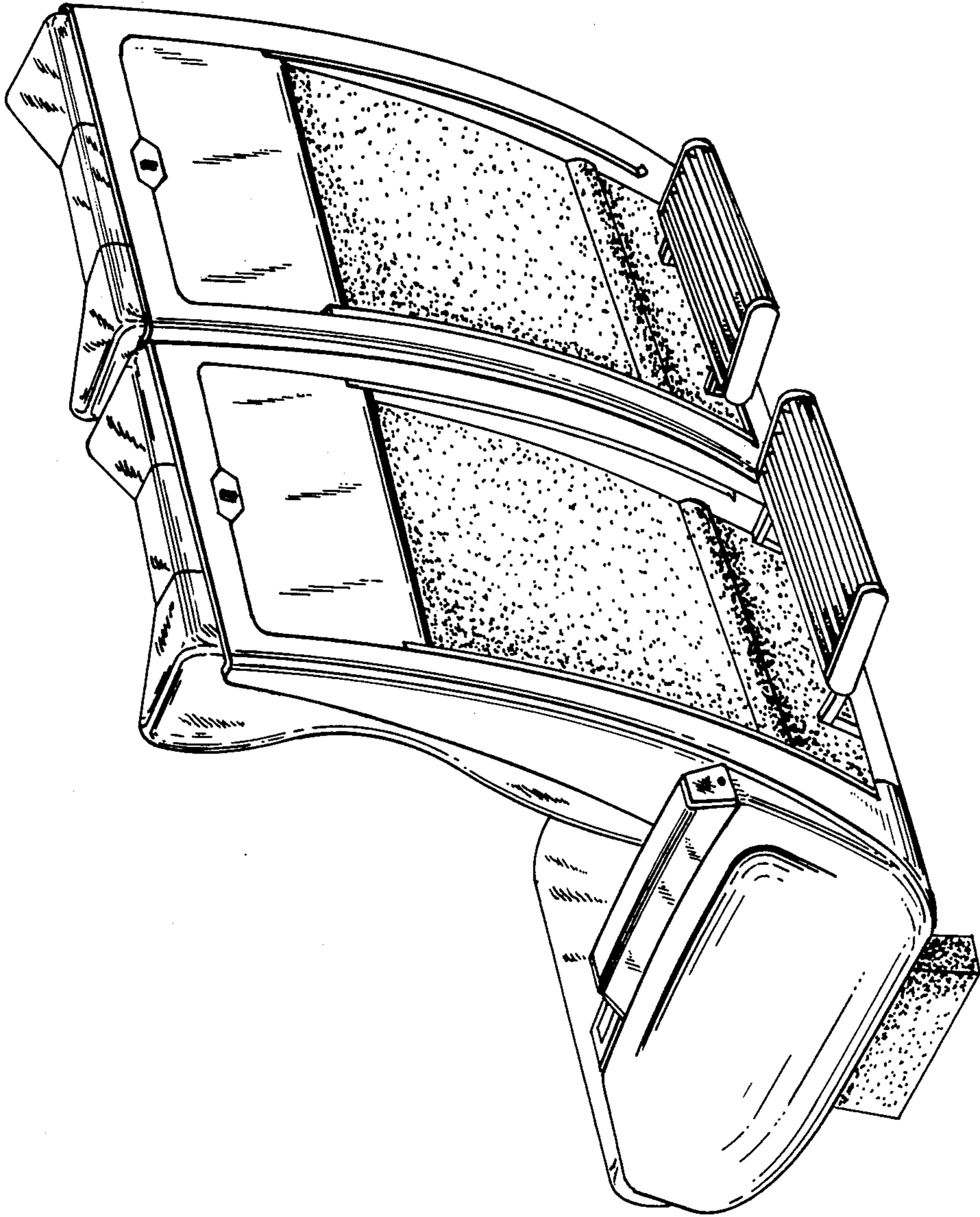

FIG. 5