

[54] LIFT TRUCK CAB

[76] Inventor: Robert P. Martin, Sr., 7809 W. 130th St., Parma, Ohio 44129

[**] Term: 14 Years

[21] Appl. No.: 769,540

[22] Filed: Feb. 17, 1977

[51] Int. Cl. D12-05

[52] U.S. Cl. D12/61

[58] Field of Search D12/61, 57; D15/30; 180/89.1, 89.12, 89.13, 89.16, 89.18, 89.19; 296/28 C

[56] References Cited

PUBLICATIONS

Modern Materials Handling, 7/76, p. 52, Cab on front end loader, bottom left side of page.

Modern Materials Handling, 6/76, p. 77, Martin Cab, third down from top right side of page.

Implement & Tractor, 8/21/76, p. 24, Lift truck cab, bottom right side of page.

Construction Methods & Equipment, 9/75, p. 83, Lift truck cab, bottom center of page.

Primary Examiner—Wallace R. Burke

Assistant Examiner—James M. Gandy

Attorney, Agent, or Firm—Harold F. McNenny

[57] CLAIM

The ornamental design for a lift truck cab, as shown.

DESCRIPTION

FIG. 1 is a side elevational view of the lift truck cab showing my new design;

FIG. 2 is a top plan view thereof;

FIG. 3 is a front elevational view thereof;

FIG. 4 is a rear elevational view thereof;

FIG. 5 is a front, side perspective view thereof it being understood that the broken lines are for illustrative purposes only; and

FIG. 6 is a rear, side perspective view of FIG. 5.

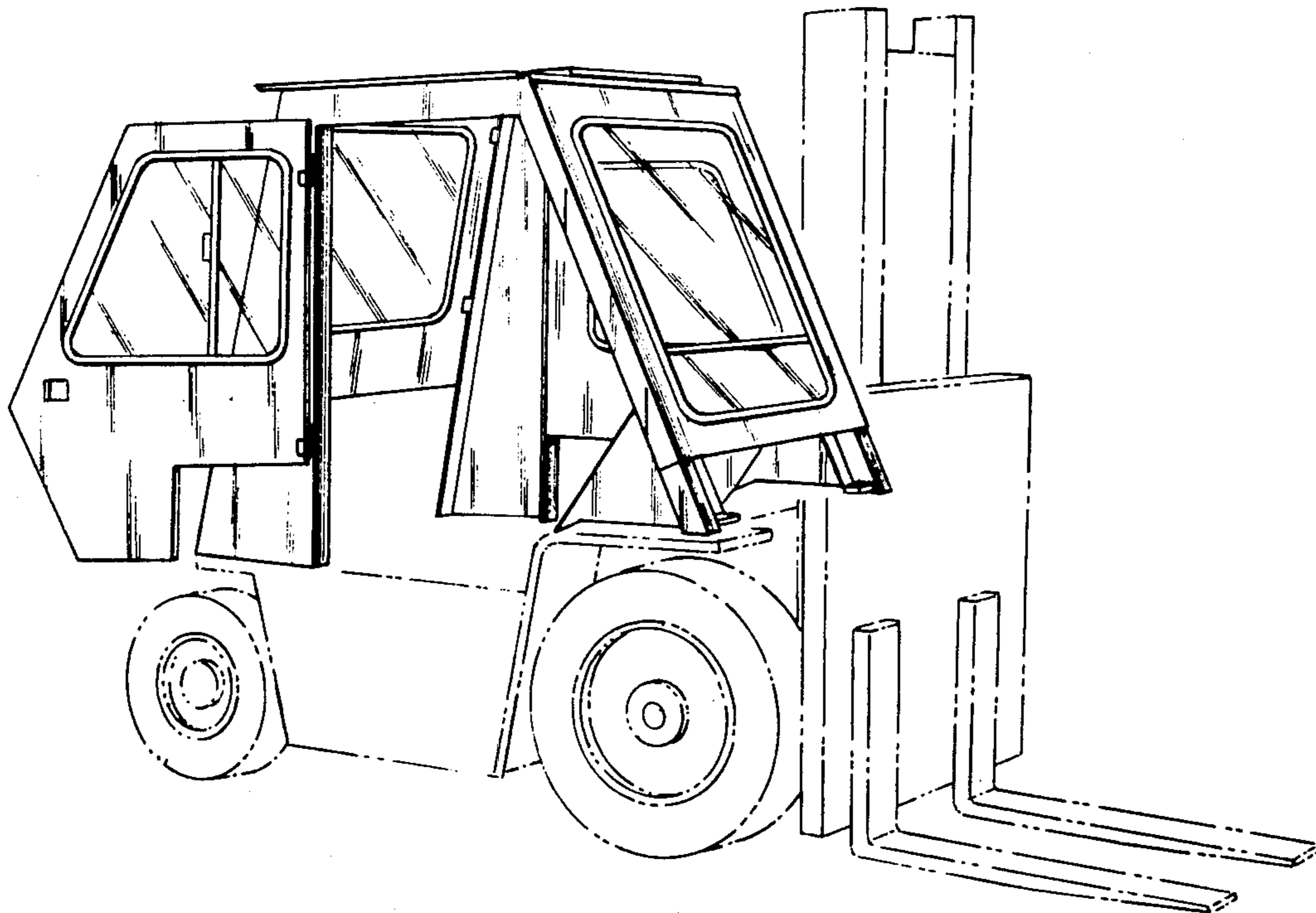

Fig. 2

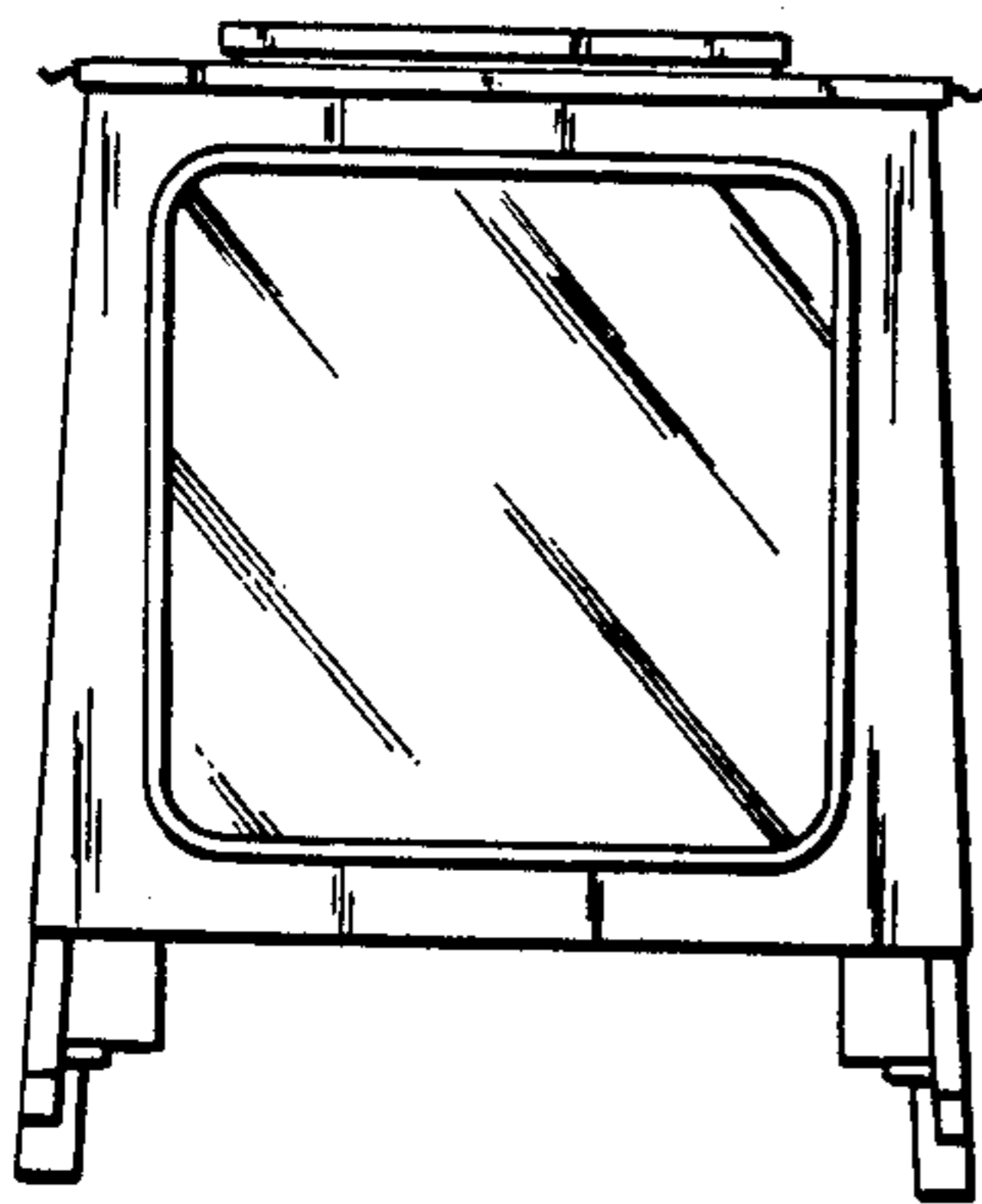
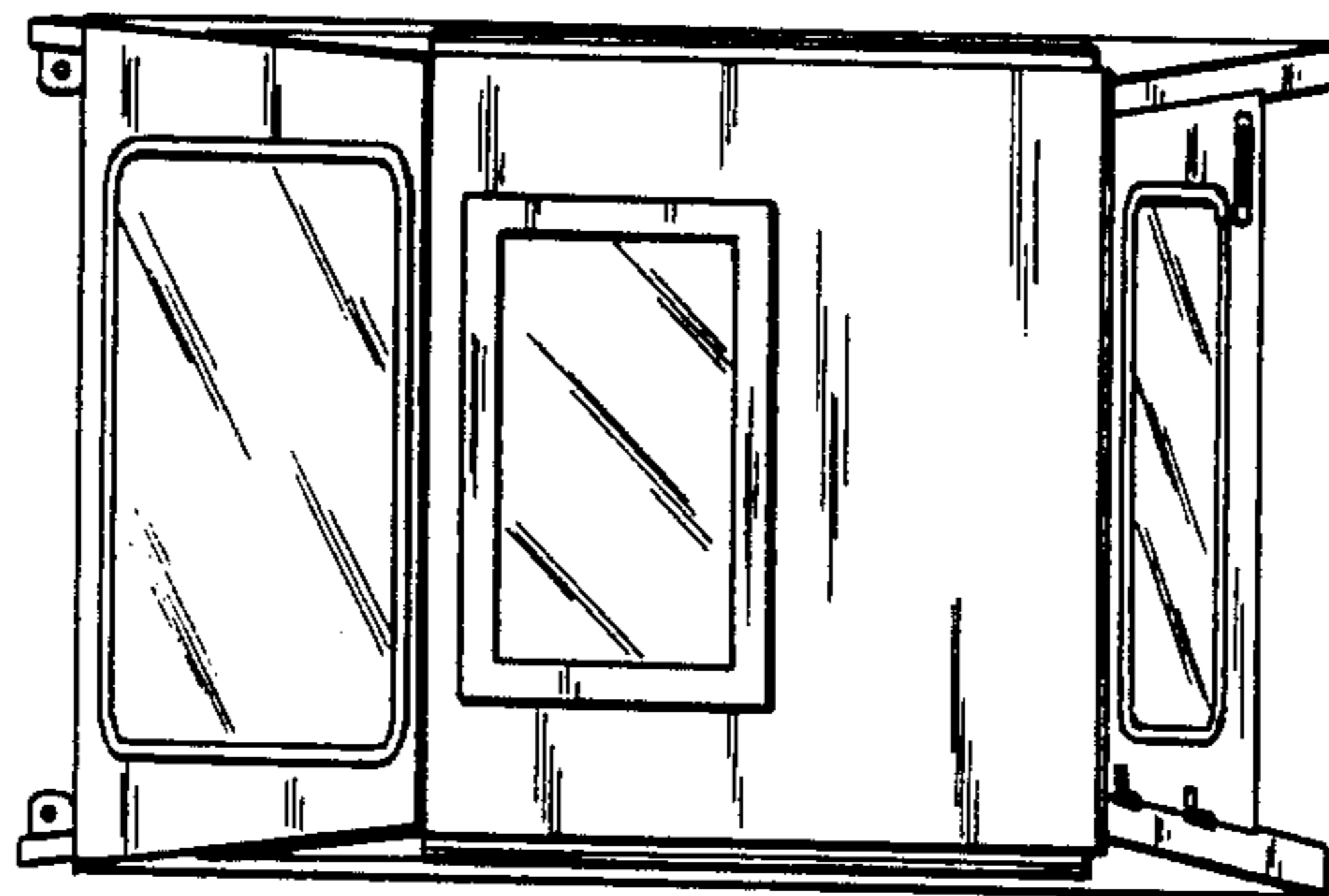

Fig. 3

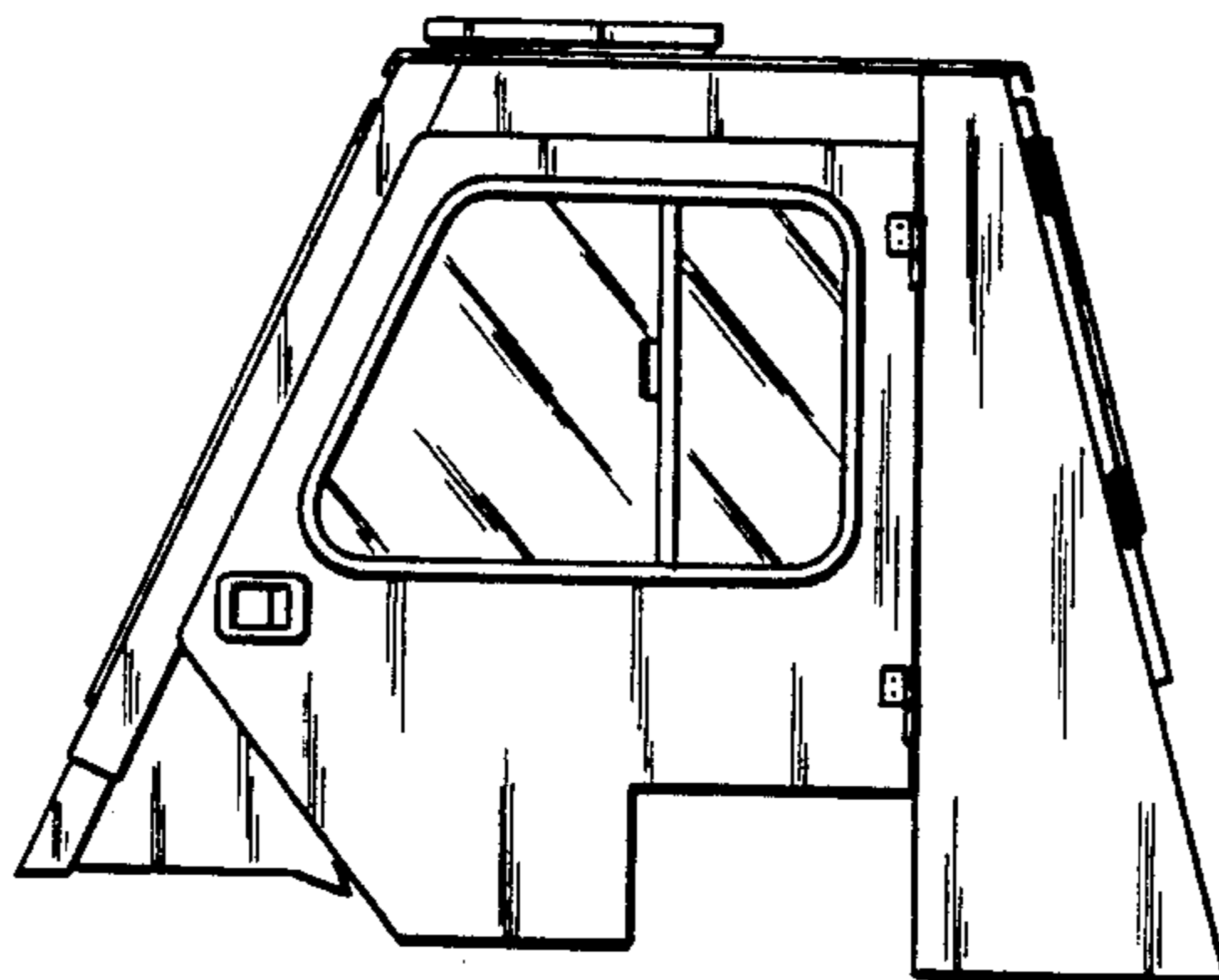

Fig. 1

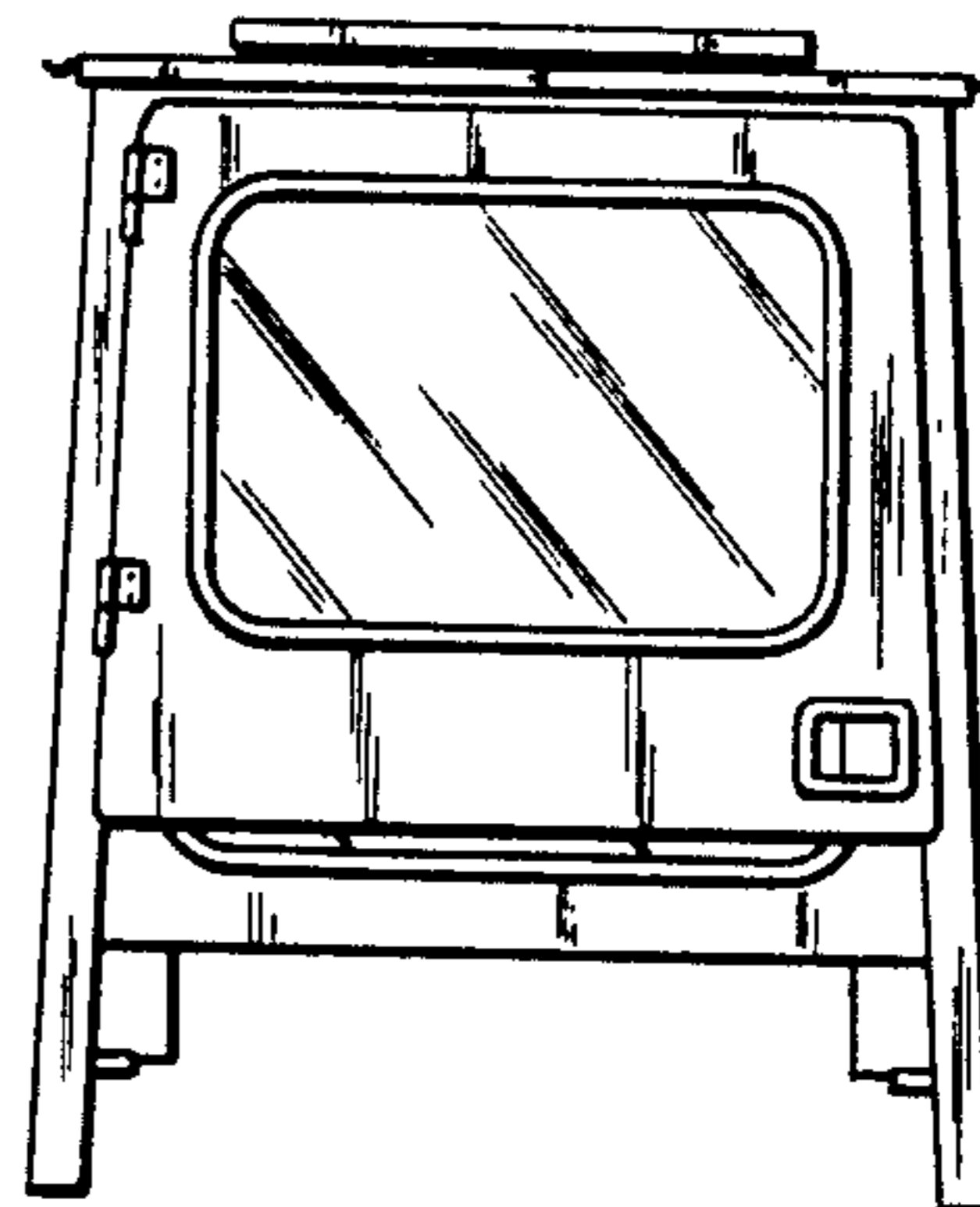

Fig. 4

Fig. 5

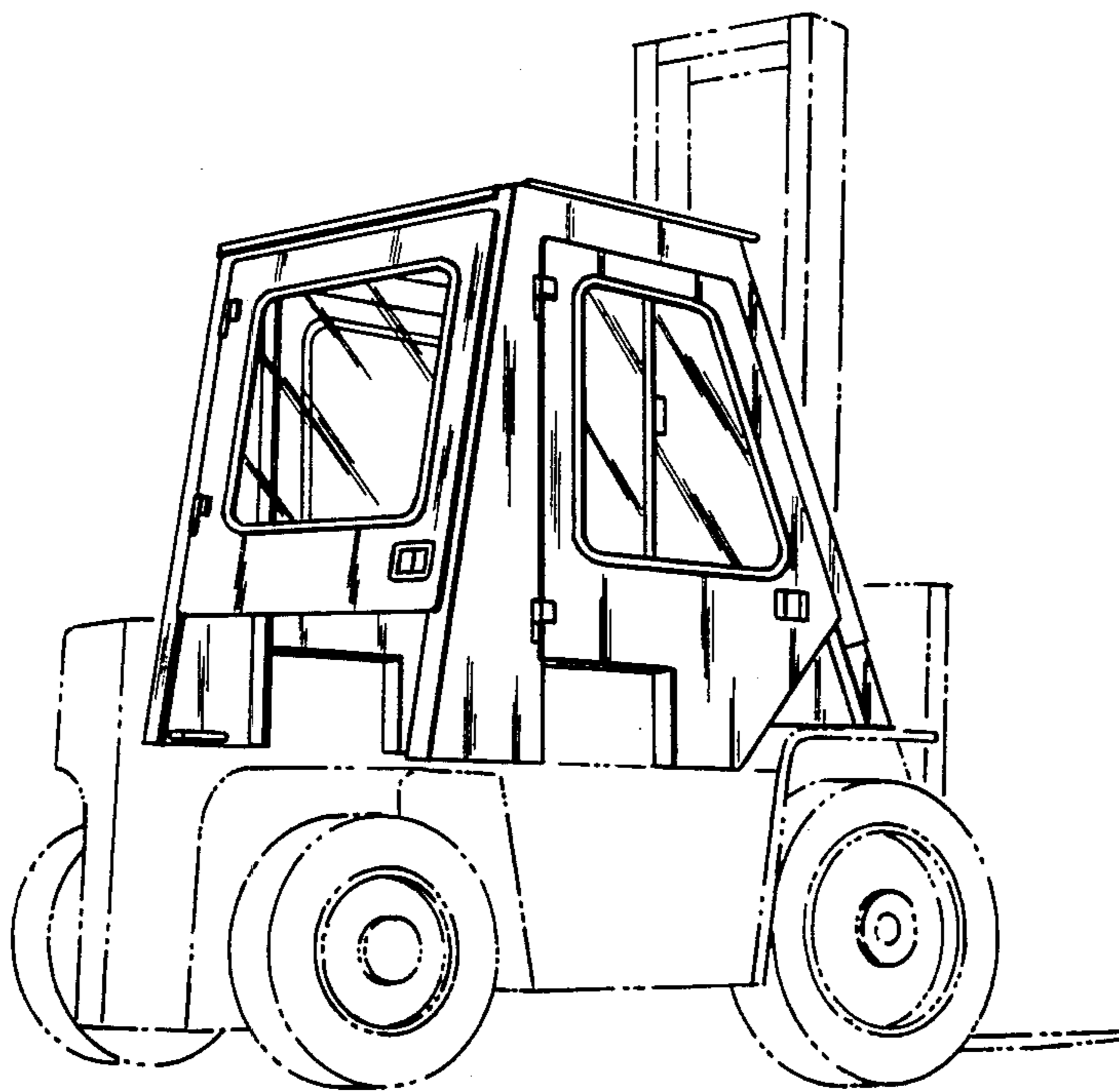
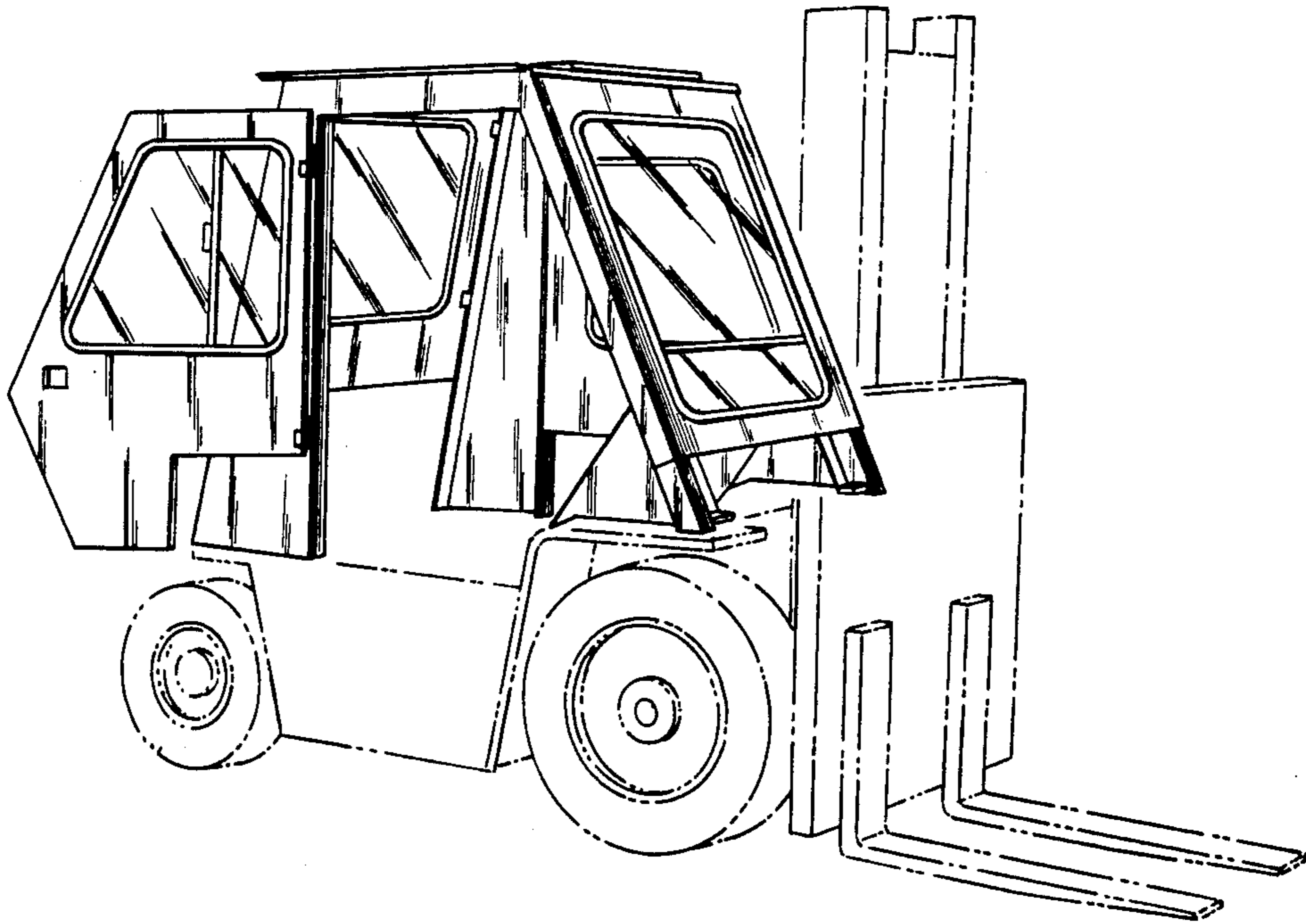

Fig. 6