

[54] **MODIFIED DELTA WING SUPERSONIC AIRCRAFT**

[76] Inventor: **Frank W. Jager**, 7050 Tait St., San Diego, Calif. 92111

[**] Term: **14 Years**

[21] Appl. No.: **691,851**

[22] Filed: **Jun. 1, 1976**

[51] Int. Cl. **D12-07**

[52] U.S. Cl. **D12/71**

[58] Field of Search **D12/71, 72; 244/36, 244/13**

[56] **References Cited**

U.S. PATENT DOCUMENTS

D. 183,108 6/1958 Price D12/71

D. 187,349	3/1960	Culver	D12/71
D. 202,152	8/1965	Tecton	D12/71
D. 229,494	12/1973	Sather	D12/71 X
2,511,502	6/1950	Gluhareff	244/13

Primary Examiner—Alan P. Douglas
Attorney, Agent, or Firm—Roy L. Knox

[57] **CLAIM**

The ornamental design for a modified delta wing supersonic aircraft, as shown.

DESCRIPTION

FIG. 1 is a perspective view of a modified delta wing supersonic aircraft showing my new design; FIG. 2 is a top plan view thereof; FIG. 3 is a bottom plan view thereof; FIG. 4 is a side elevational view thereof; FIG. 5 is a front elevational view thereof; and FIG. 6 is a rear elevational view thereof.

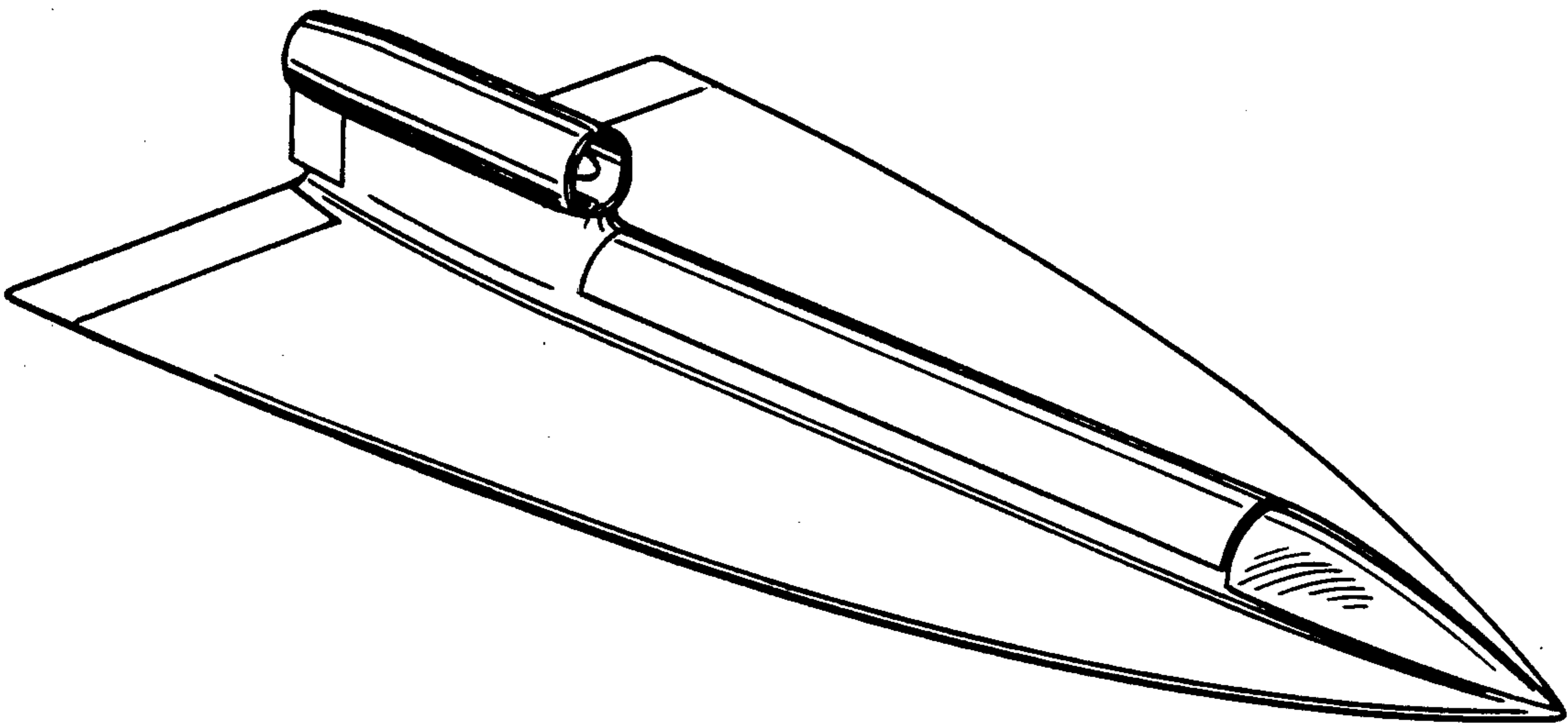

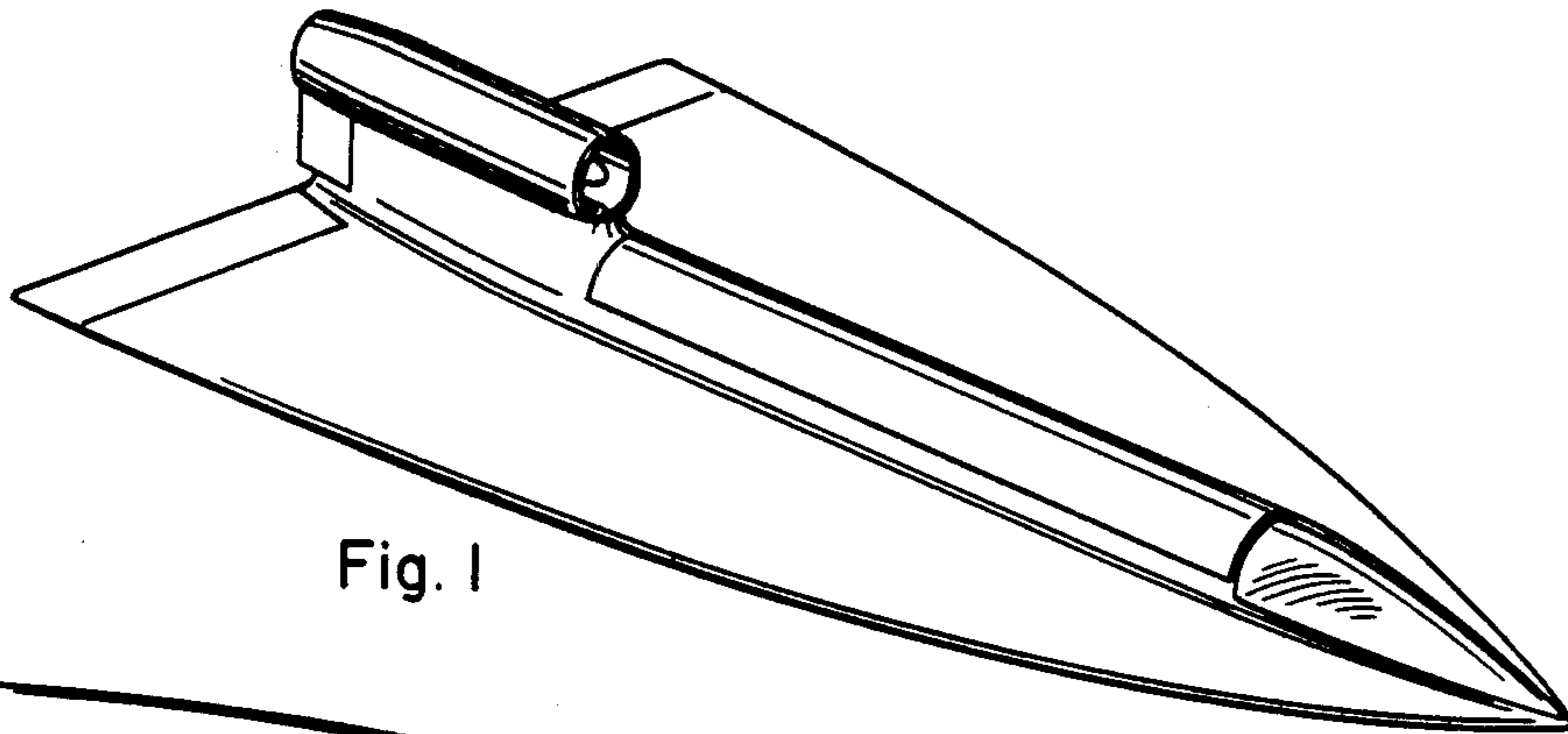

Fig. 1

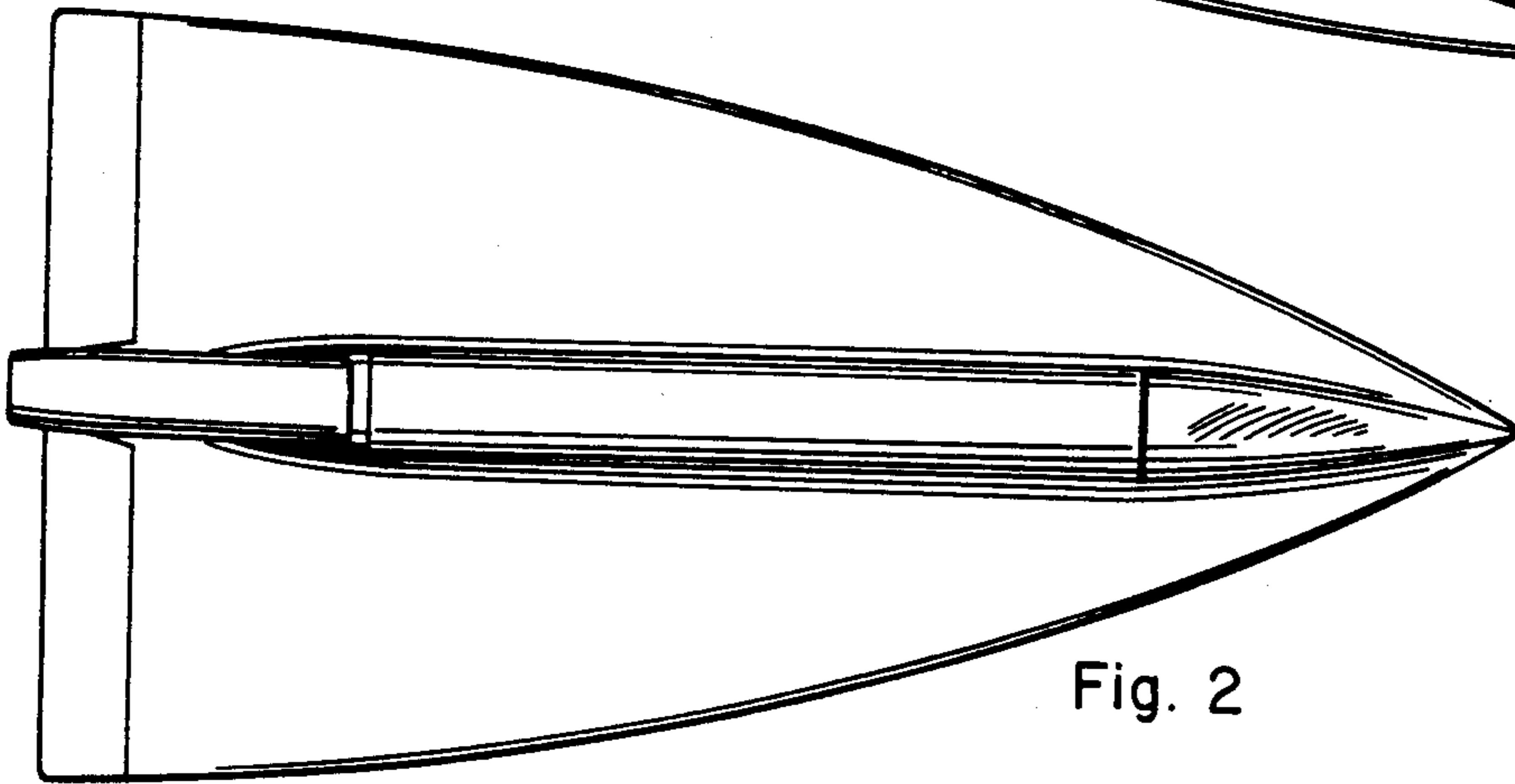

Fig. 2

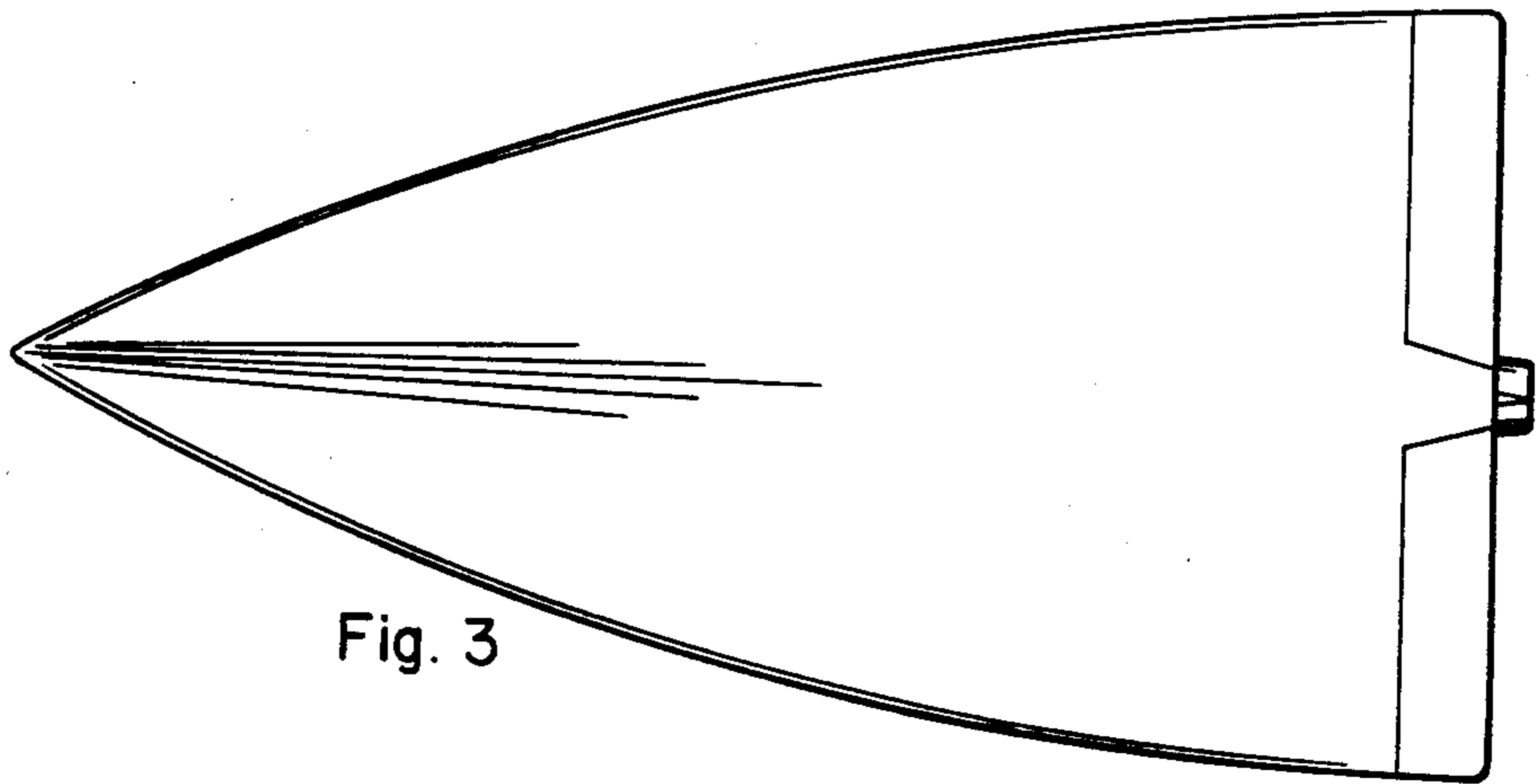

Fig. 3

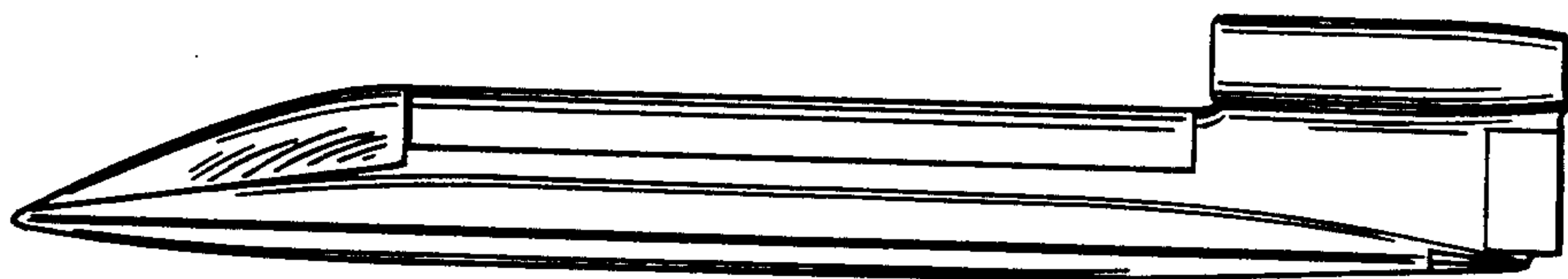

Fig. 4



Fig. 5

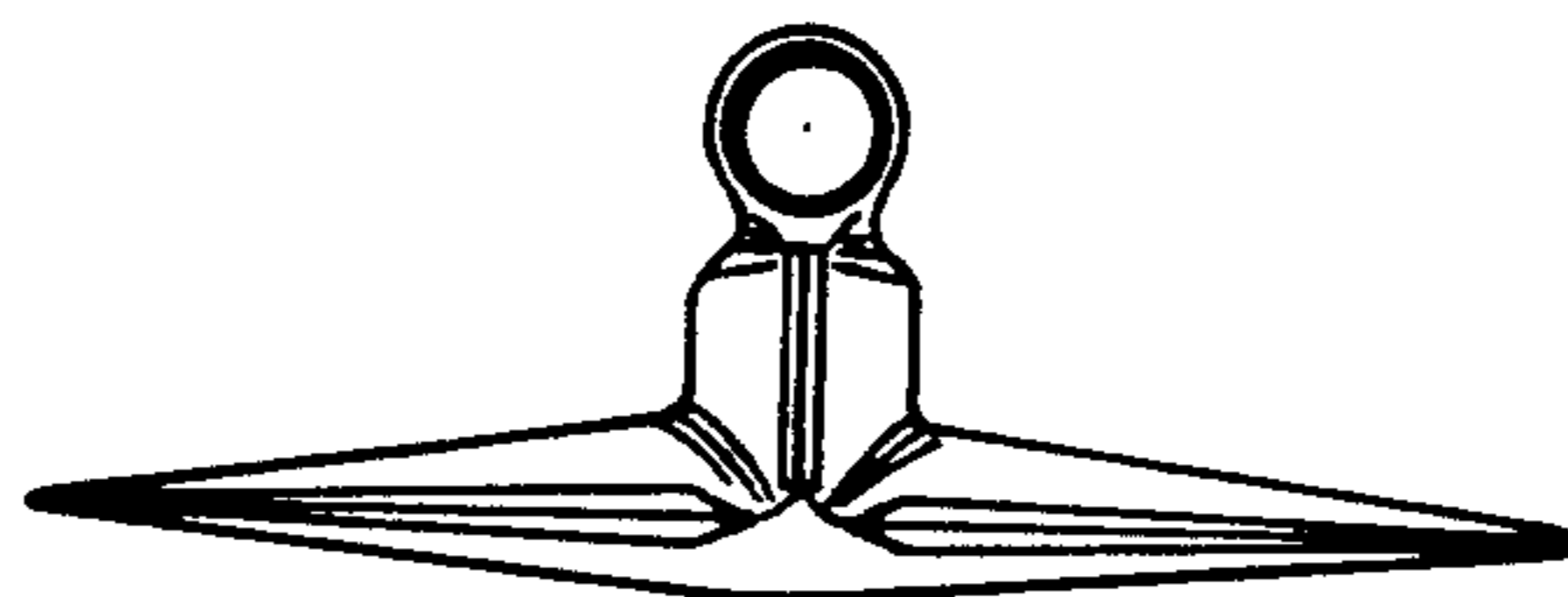

Fig. 6