

[54] TOY AUTO

[76] Inventor: Helmut Darda, 7712 Blumberg, Im Tal, Germany

[**] Term: 7 Years

[21] Appl. No.: 641,571

[22] Filed: Dec. 17, 1975

[51] Int. Cl. D21-01

[52] U.S. Cl. D34/15 AJ

[58] Field of Search D34/15 AJ, 15 D, 15 AM, D34/15 AN; 46/103, 105, 201, 202, 204, 206, 210, 211, 212, 213, 222

[56] References Cited

U.S. PATENT DOCUMENTS

D. 211,809 7/1968 Genin D34/15 AJ

D. 222,491 10/1971 Gorfain D34/15 AJ
3,583,095 6/1971 Fahrendorff 46/202

OTHER PUBLICATIONS

Nacoral Flier, 2-1973, #1004, "Maxwell-Roadster".

Primary Examiner—Joel Stearman

Assistant Examiner—C. A. Rademaker

Attorney, Agent, or Firm—Eric H. Waters

[57] CLAIM

The ornamental design for a toy auto, as shown.

DESCRIPTION

FIG. 1 is a front perspective view of a toy auto showing my new design;

FIG. 2 is another perspective view thereof showing the side opposite that shown in FIG. 1;

FIG. 3 is a rear elevational view thereof; and

FIG. 4 is a bottom plan view thereof.

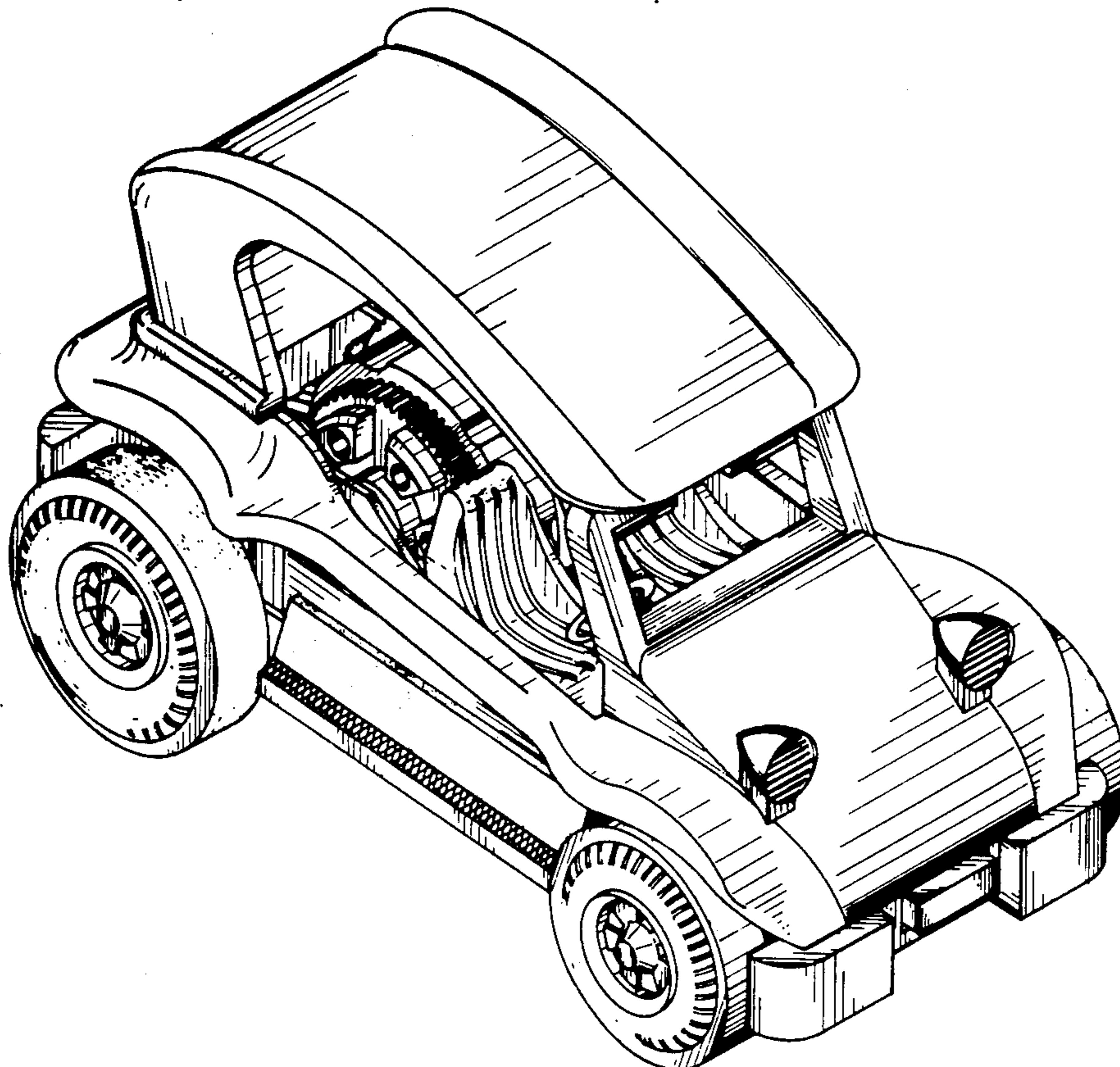

FIG. 1

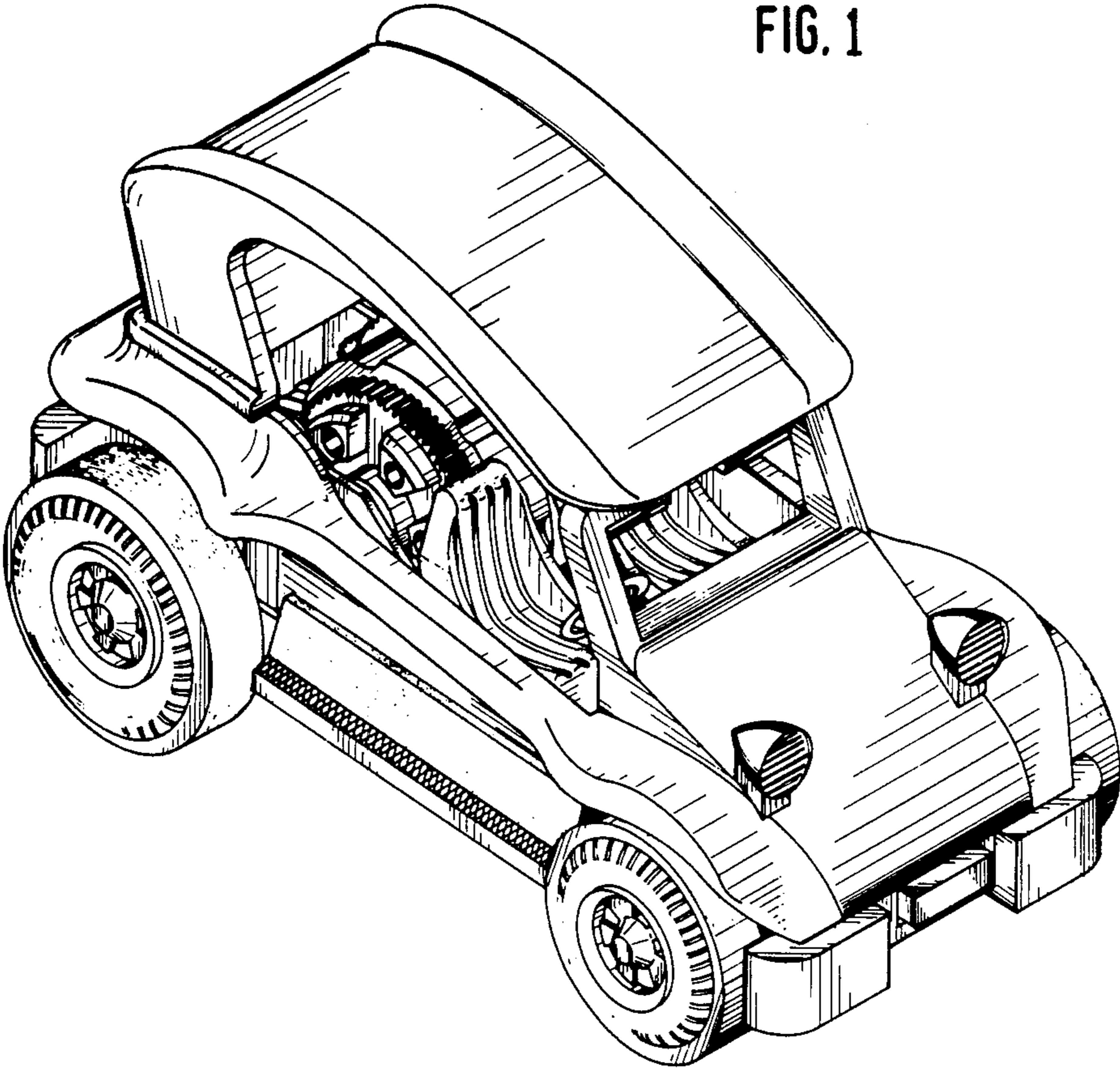

FIG. 2

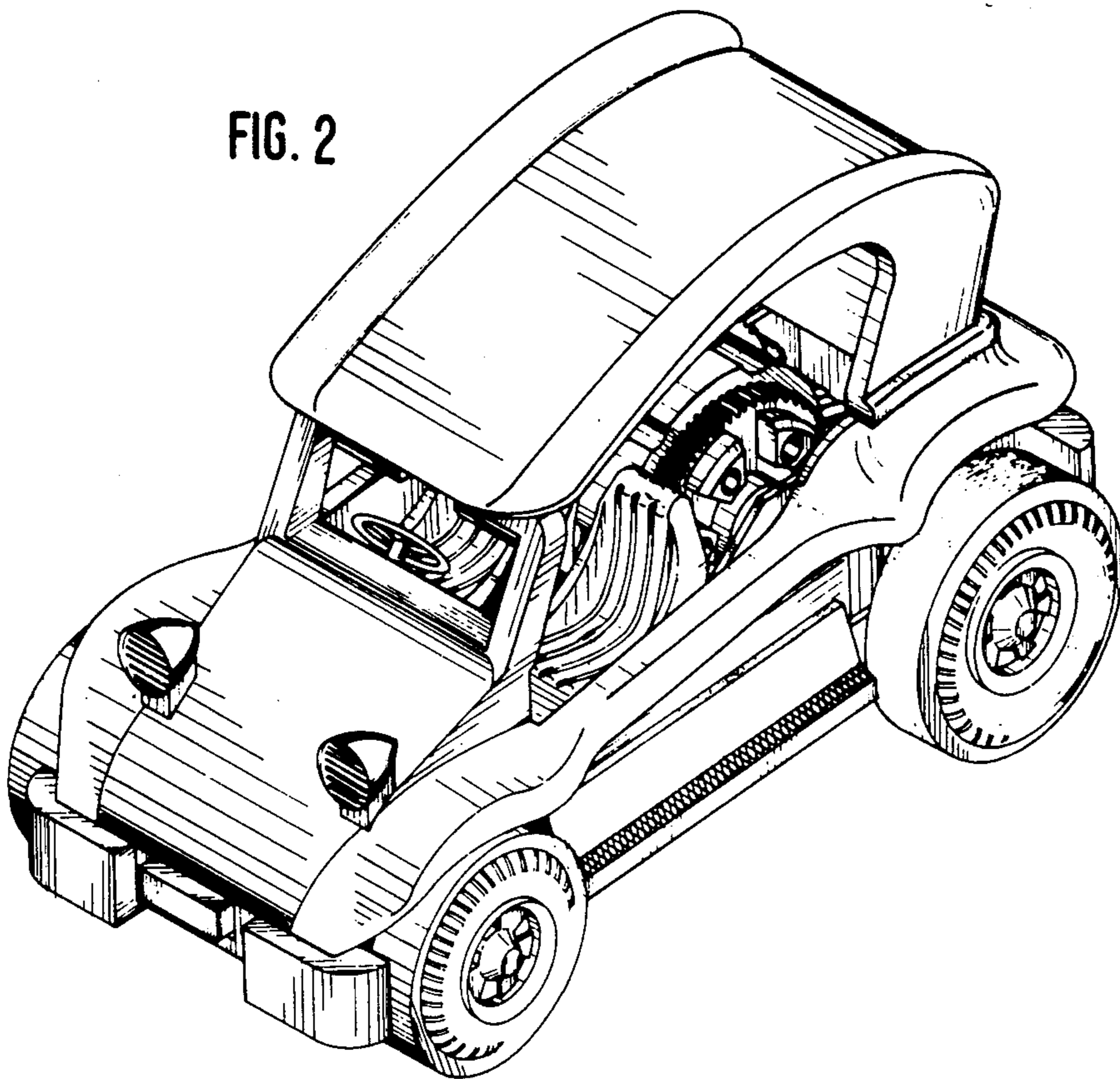

FIG. 4

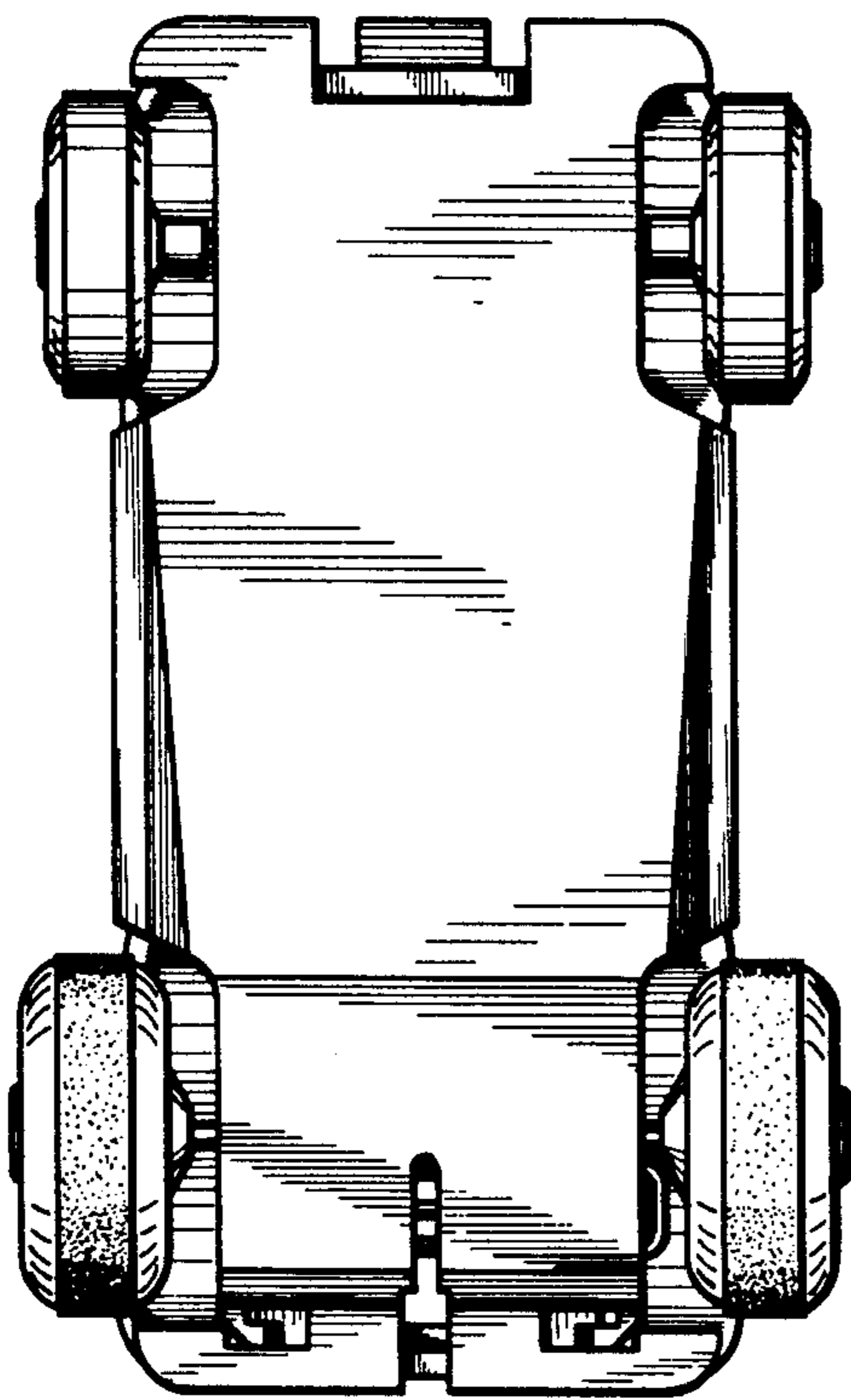

FIG. 3

