

[54] THREE-WHEELED VEHICLE

[76] Inventor: O. David Edmonson, 6276 Greenleaf Trail, Apple Valley, Minn. 55124

[**] Term: 14 Years

[21] Appl. No.: 703,758

[22] Filed: Jul. 9, 1976

[51] Int. Cl. D12-08

[52] U.S. Cl. D12/85

[58] Field of Search D12/85; 180/25 R, 26 R, 180/27; 296/28 R

[56] References Cited

U.S. PATENT DOCUMENTS

D. 137,965	5/1944	Harris	D12/85
D. 190,225	5/1961	Garcia	D12/85

OTHER PUBLICATIONS

Popular Mechanics, 4/74, p. 80, Duo Delta, bottom of page.

Primary Examiner—Wallace R. Burke
Assistant Examiner—James M. Gandy

[57] CLAIM

The ornamental design for a three-wheeled vehicle, substantially as shown.

DESCRIPTION

FIG. 1 is a top plan view of a three-wheeled vehicle showing my design;

FIG. 2 is a side elevational view thereof, the opposite side being a mirror image of the side shown herein except for the omission of the passenger door;

FIG. 3 is a bottom plan view thereof;

FIG. 4 is a front elevational view thereof; and

FIG. 5 is a rear elevational view thereof.

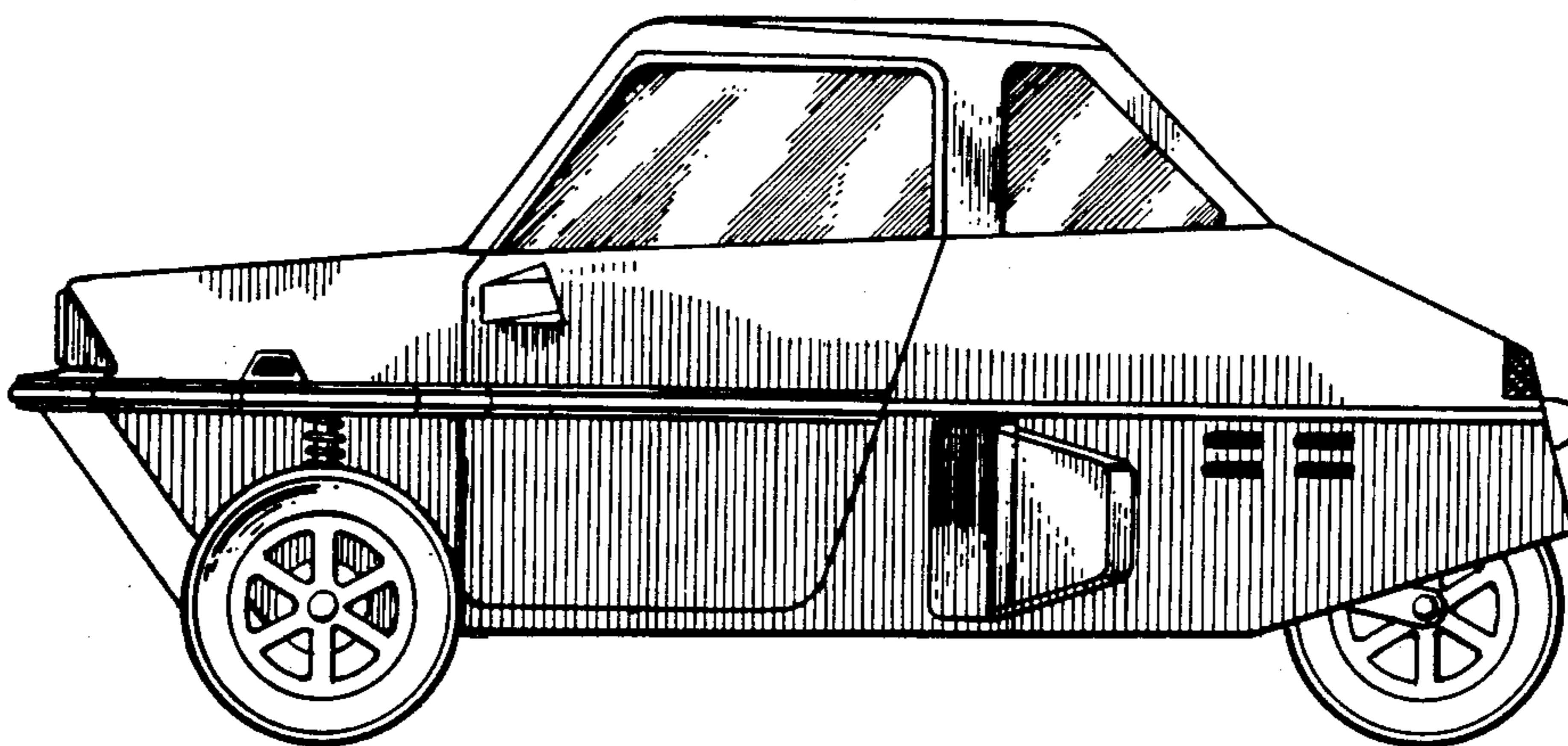
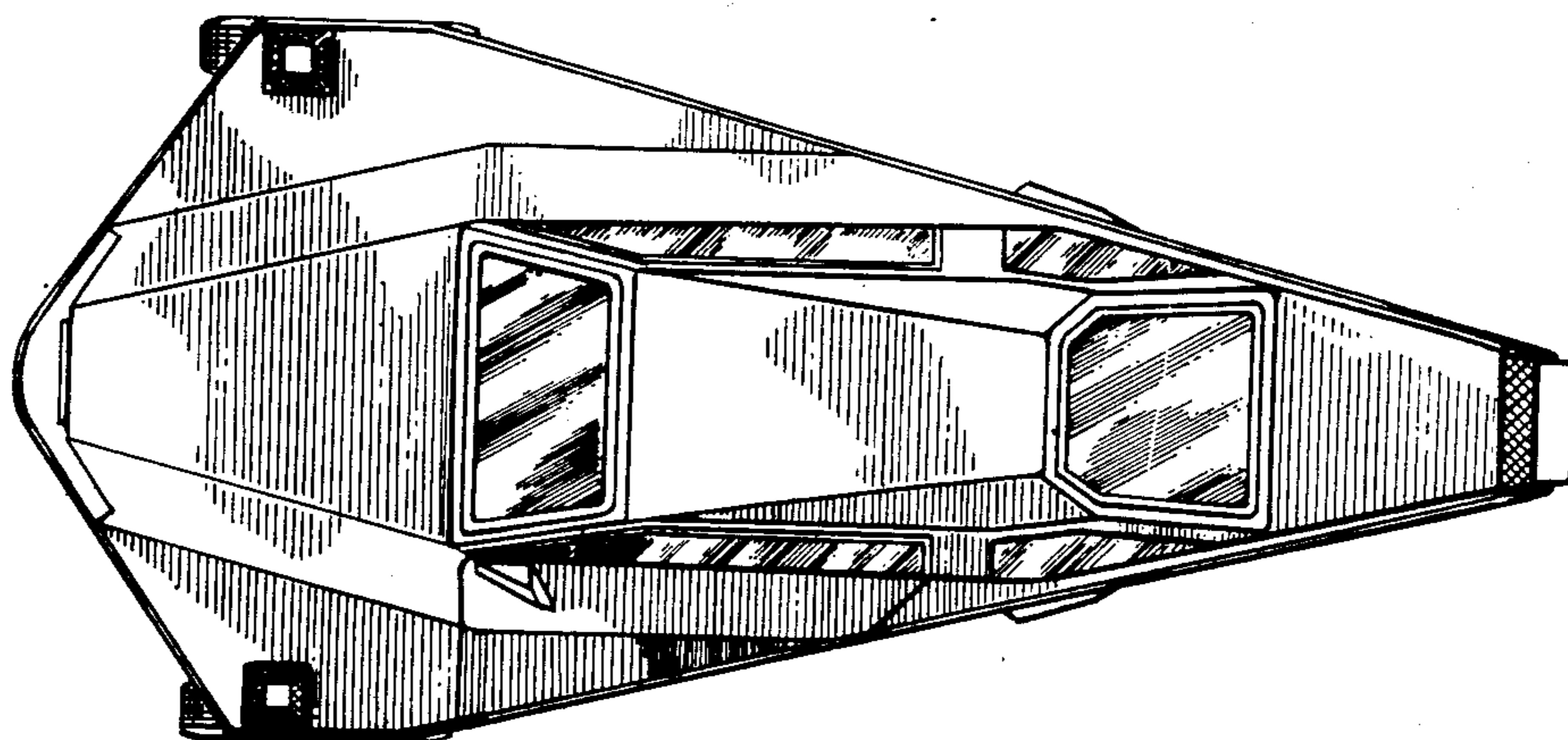

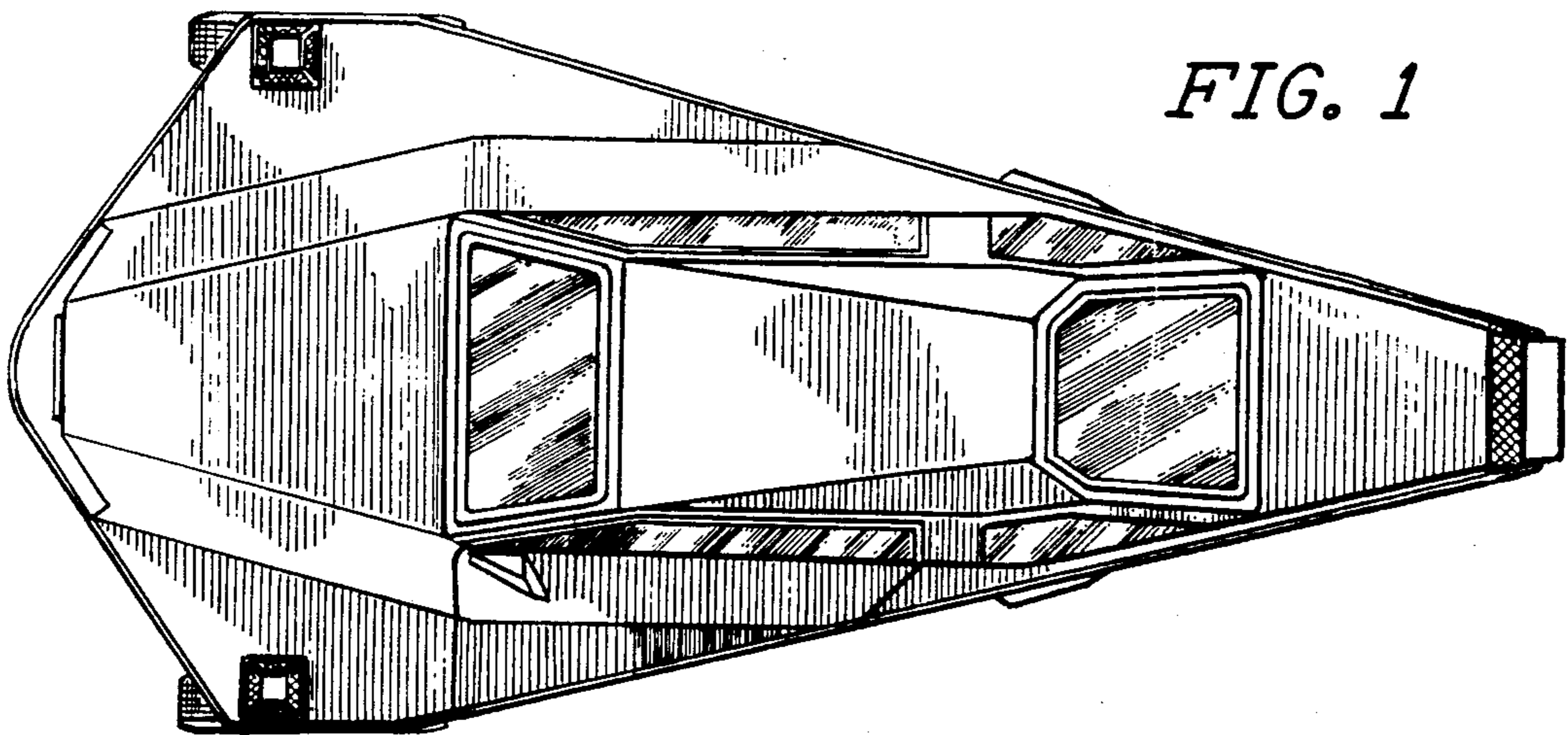

FIG. 1

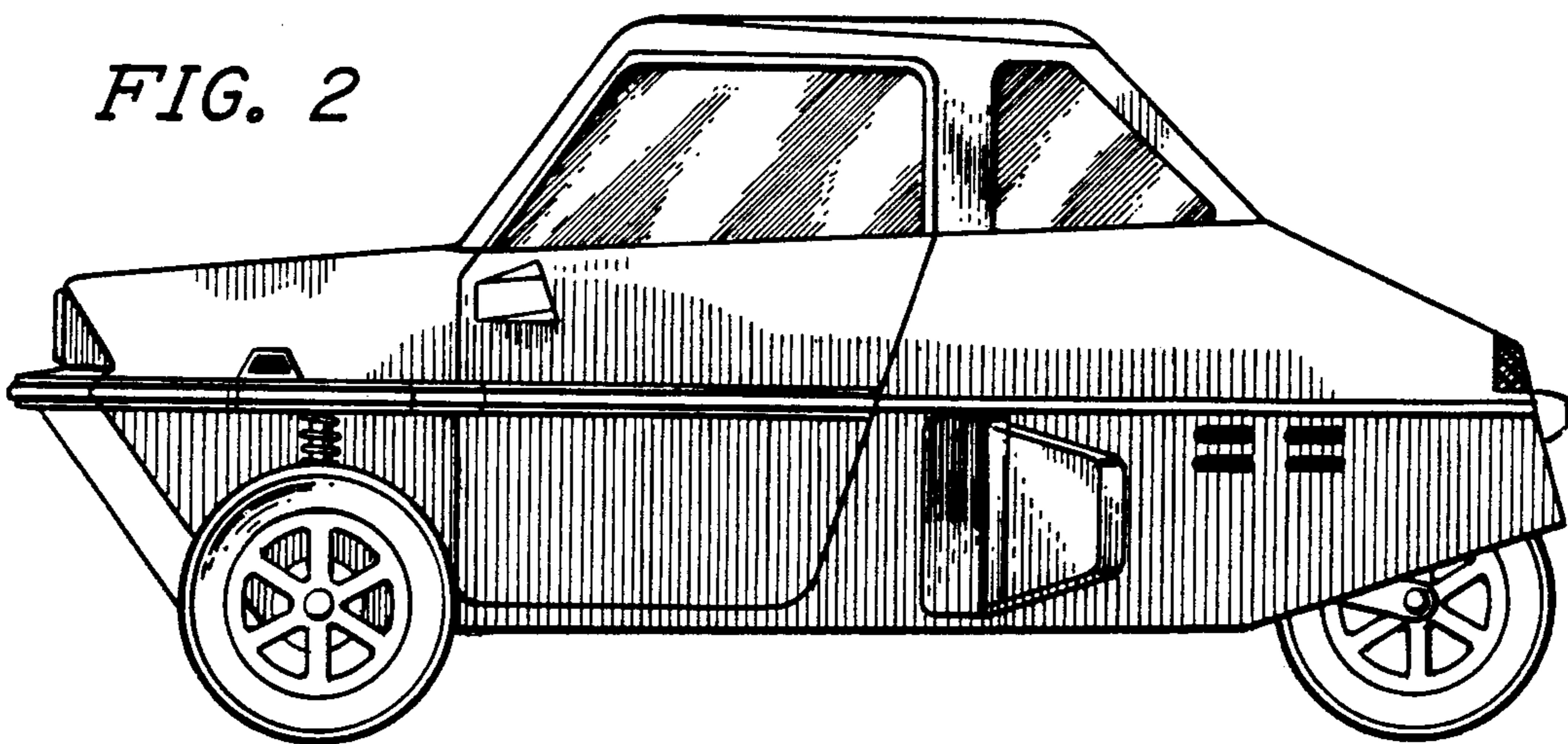

FIG. 2

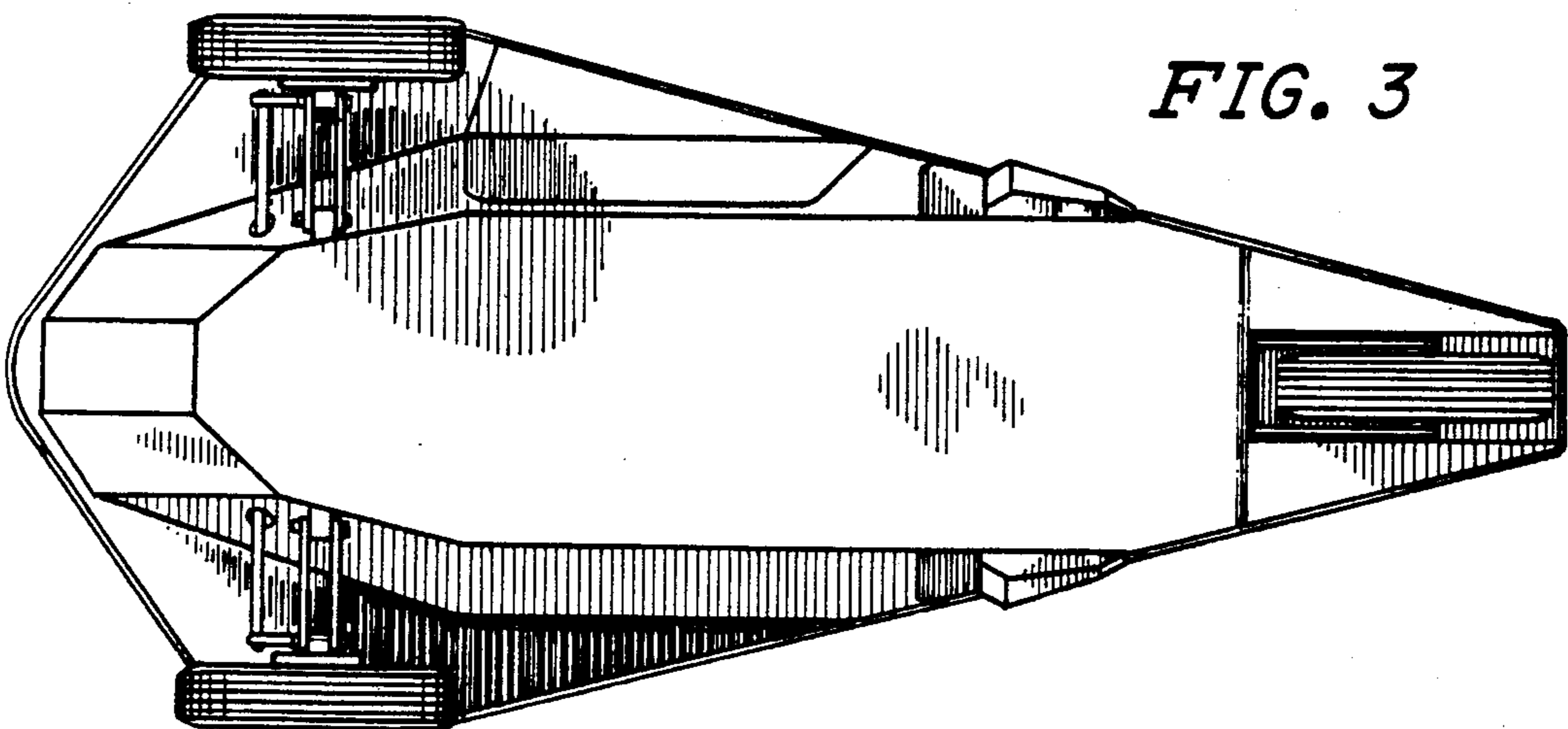

FIG. 3

FIG. 4

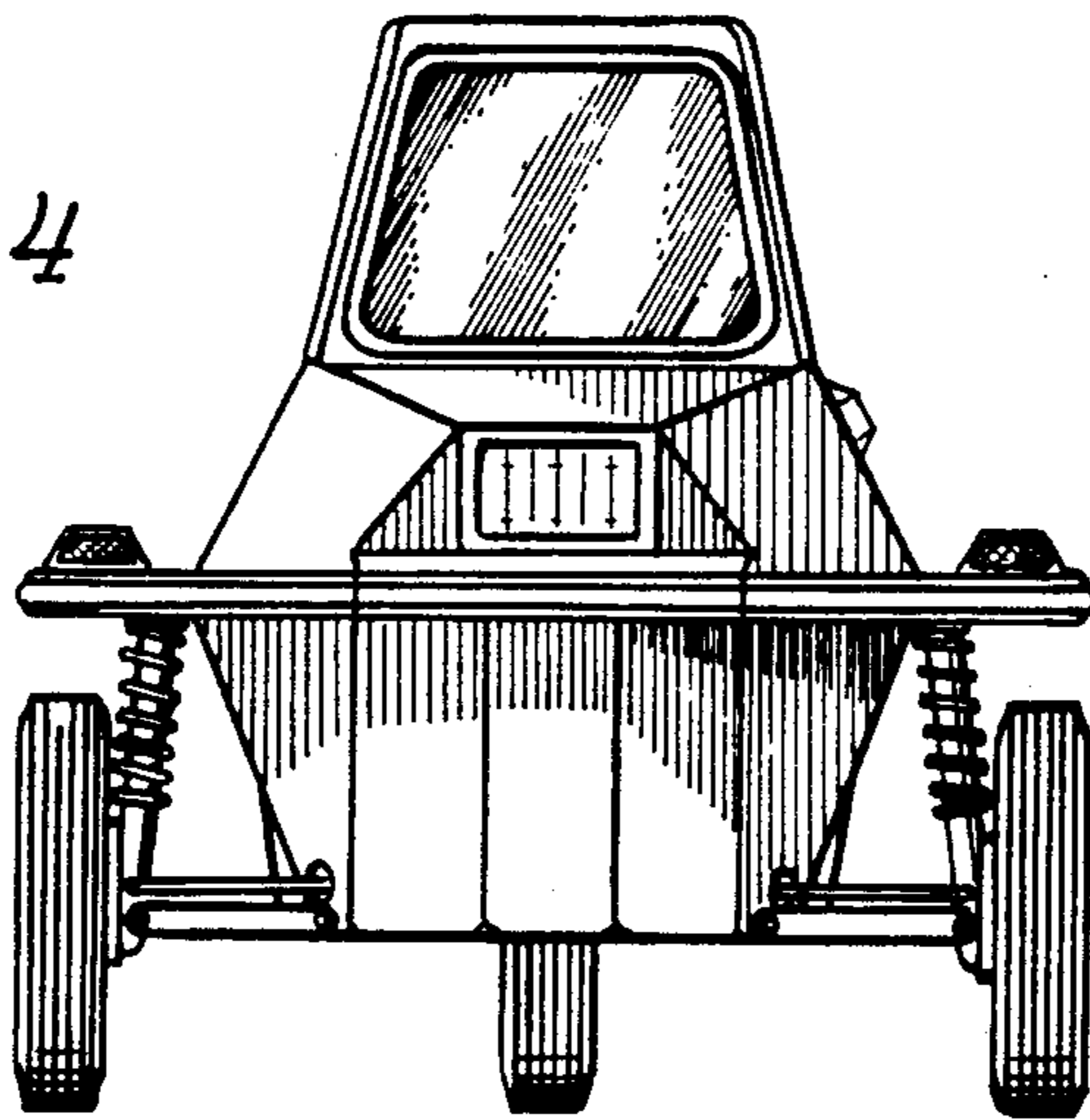

FIG. 5

