

[54] MOTORCYCLE

[75] Inventors: Tadahiro Kurishima, Akashi; Tohru Yamauchi, Kobe, both of Japan

[73] Assignee: Kawasaki Jukogyo Kabushiki Kaisha, Kobe, Japan

[**] Term: 14 Years

[21] Appl. No.: 800,097

[22] Filed: May 24, 1977

[30] Foreign Application Priority Data

Nov. 30, 1976 [JP] Japan 51-46811

[51] Int. Cl. D12-11

[52] U.S. Cl. D12/110

[58] Field of Search D12/110; 180/31, 32, 180/33 R, 34

[56] References Cited

PUBLICATIONS

Cycle, 4/76, P35, Kawasaki KZ900 Ltd.
Cycle, 3/74, P40, BMW R90S, top of page.
Cycle, 6/76, P45, Yamaha 750.
Cycle World, 4/74, P18, Motorcycle, bottom of page.

Primary Examiner—Wallace R. Burke
Assistant Examiner—James M. Gandy
Attorney, Agent, or Firm—Davidson C. Miller

[57] CLAIM

The ornamental design for a motorcycle, substantially as shown.

DESCRIPTION

FIG. 1 is a front elevational view of the motorcycle showing our new design;
FIG. 2 is a back elevational view thereof;
FIG. 3 is a right side elevational view thereof;
FIG. 4 is a left side elevational view thereof;
FIG. 5 is a top plan view thereof; and
FIG. 6 is a bottom plan view thereof.

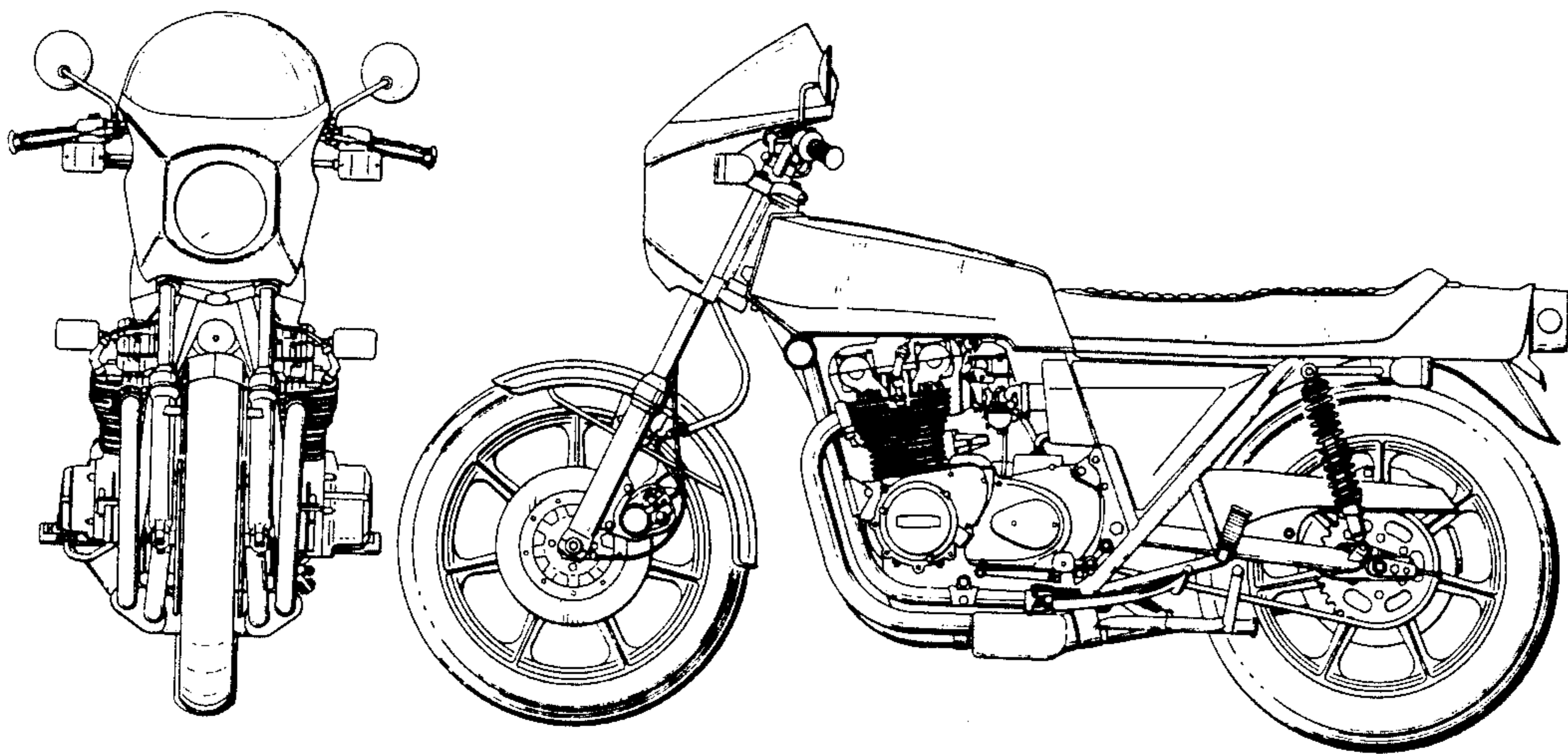

FIG. 3

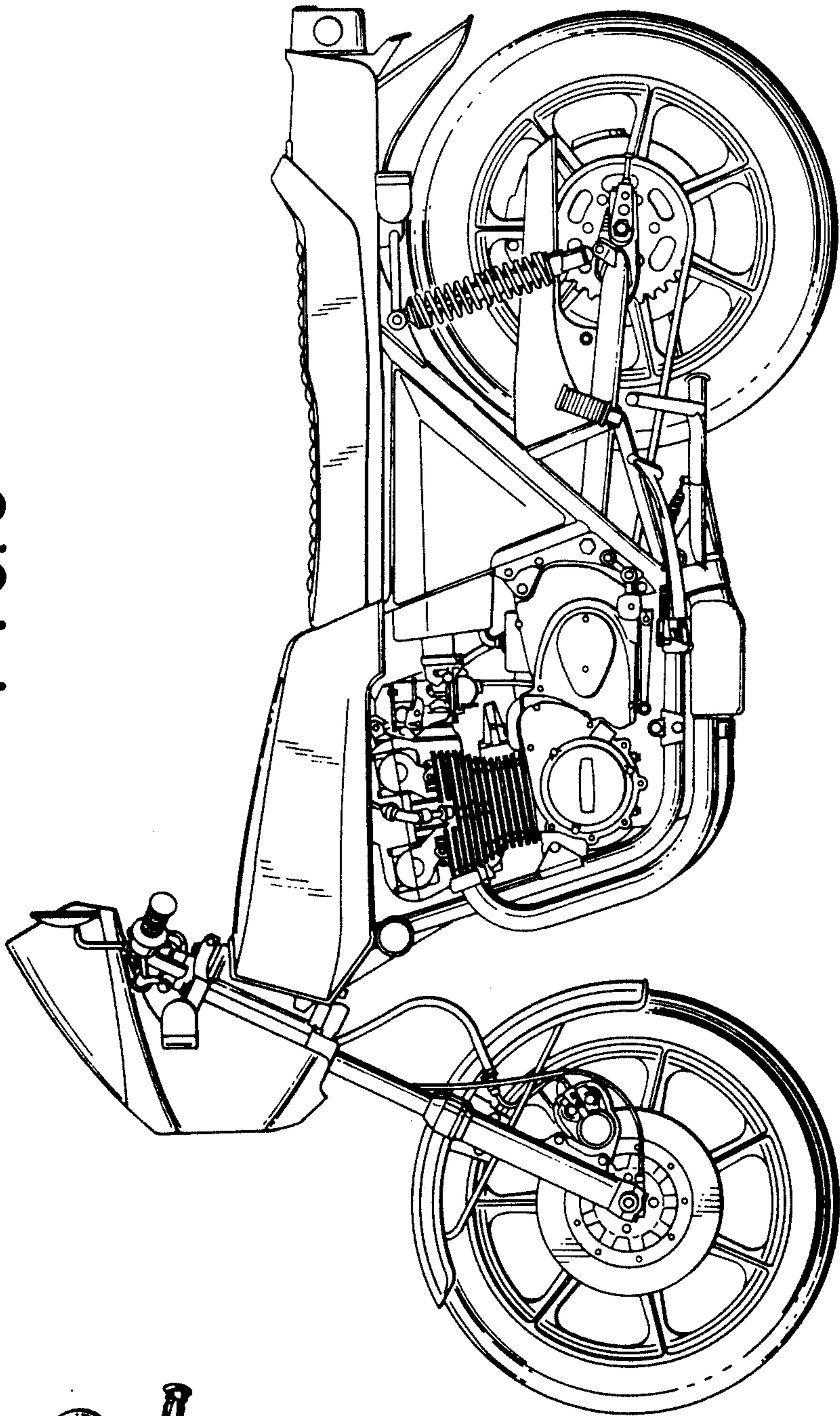

FIG. 1

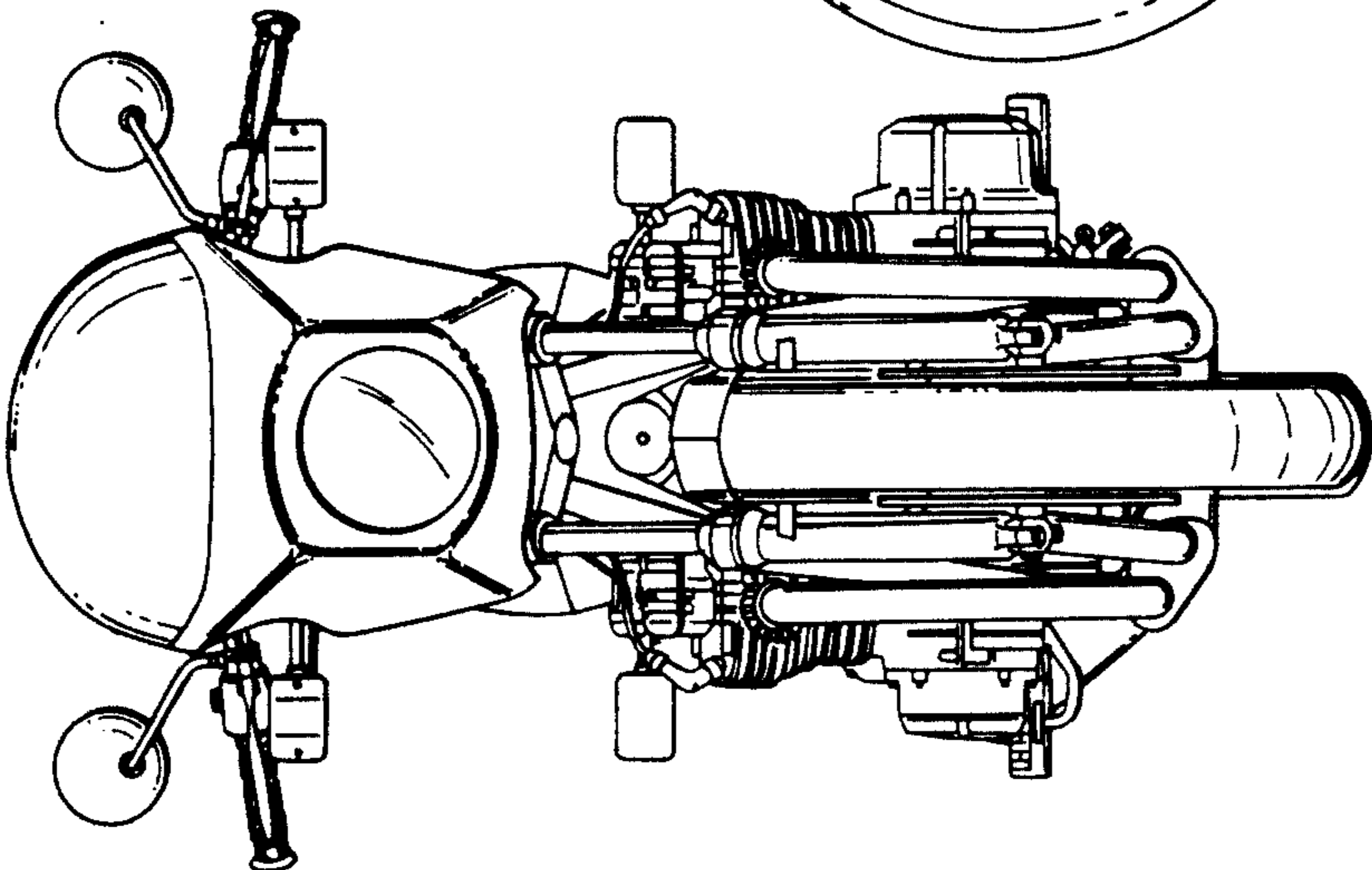

FIG. 4

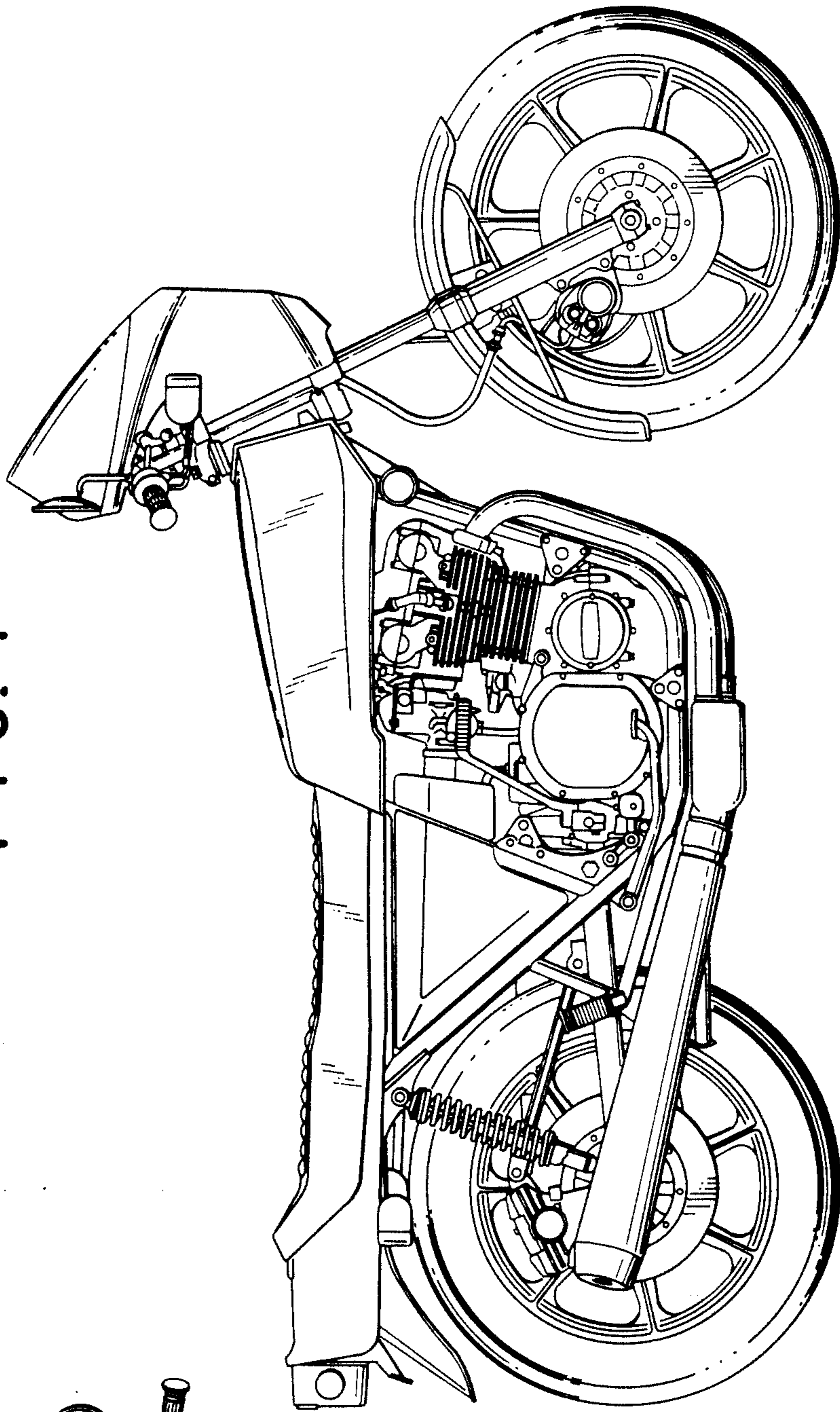

FIG. 2

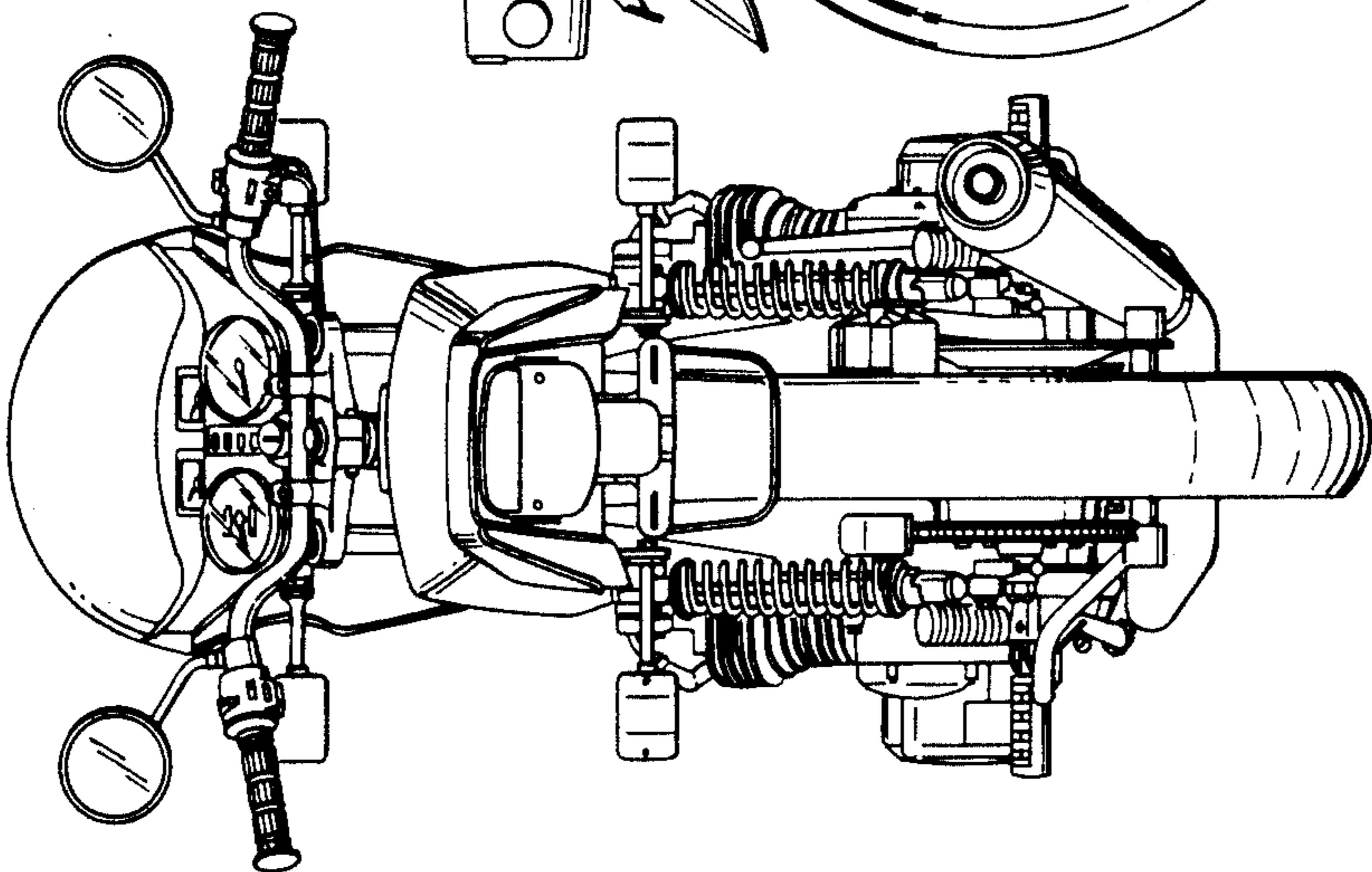

FIG. 5

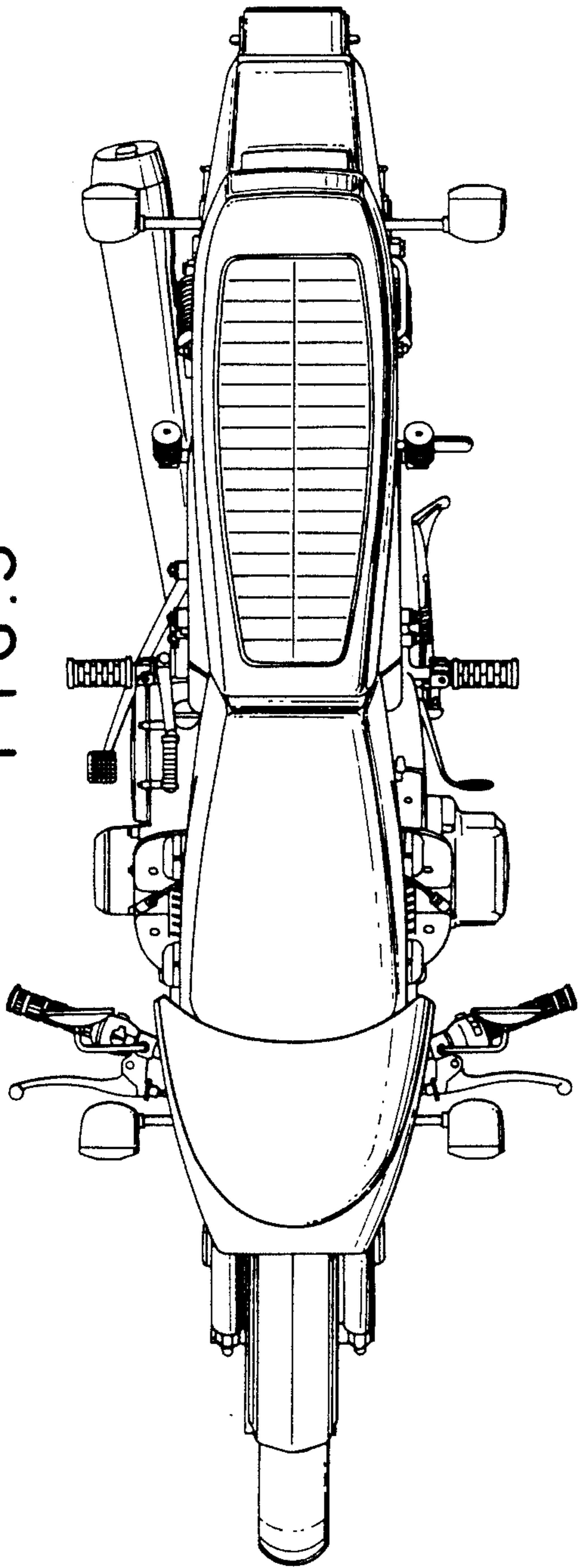

FIG. 6

