

[54] AUTOMOTIVE WHEEL

377,260 6/1973 U.S.S.R. .... 301/79

[76] Inventors: George E. Day, 1240 N. Ivy, Escondido, Calif. 92026; R. W. Johnson, 559 Larchwood Dr., San Marcos, Calif. 92069

[\*\*] Term: 14 Years

[21] Appl. No.: 776,201

[22] Filed: Mar. 10, 1977

[51] Int. Cl. .... D12-16

[52] U.S. Cl. .... D12/206; D12/209

[58] Field of Search .... D12/204-206, D12/211, 209; 301/6 CS, 9 S, 37 R, 37 P, 37 B, 37 TP, 37 L, 63 R, 63 PW, 64 R, 64 SD, 65, 66, 73, 74

[56] References Cited

U.S. PATENT DOCUMENTS

D. 170,952 11/1953 Sinclair ..... D12/206

FOREIGN PATENT DOCUMENTS

486,661 6/1938 United Kingdom ..... 301/65

OTHER PUBLICATIONS

Esquire Magazine, 9/51, p. 84, wheel.

Primary Examiner—Wallace R. Burke  
Assistant Examiner—James M. Gandy  
Attorney, Agent, or Firm—Duane C. Bowen

[57] CLAIM

The ornamental design for an automotive wheel, as shown and described.

DESCRIPTION

FIG. 1 is a front elevational view of an automotive wheel showing our new design;  
FIG. 2 is a rear elevational view thereof;  
FIG. 3 is an end elevational view thereof partially in section taken along line 3—3 in FIG. 1;  
FIG. 4 is a front elevational view of an automotive wheel showing a second embodiment of our new design;  
FIG. 5 is a rear elevational view of FIG. 4; and  
FIG. 6 is an end elevational view of FIG. 4 partially in section taken along line 6—6 in FIG. 4.

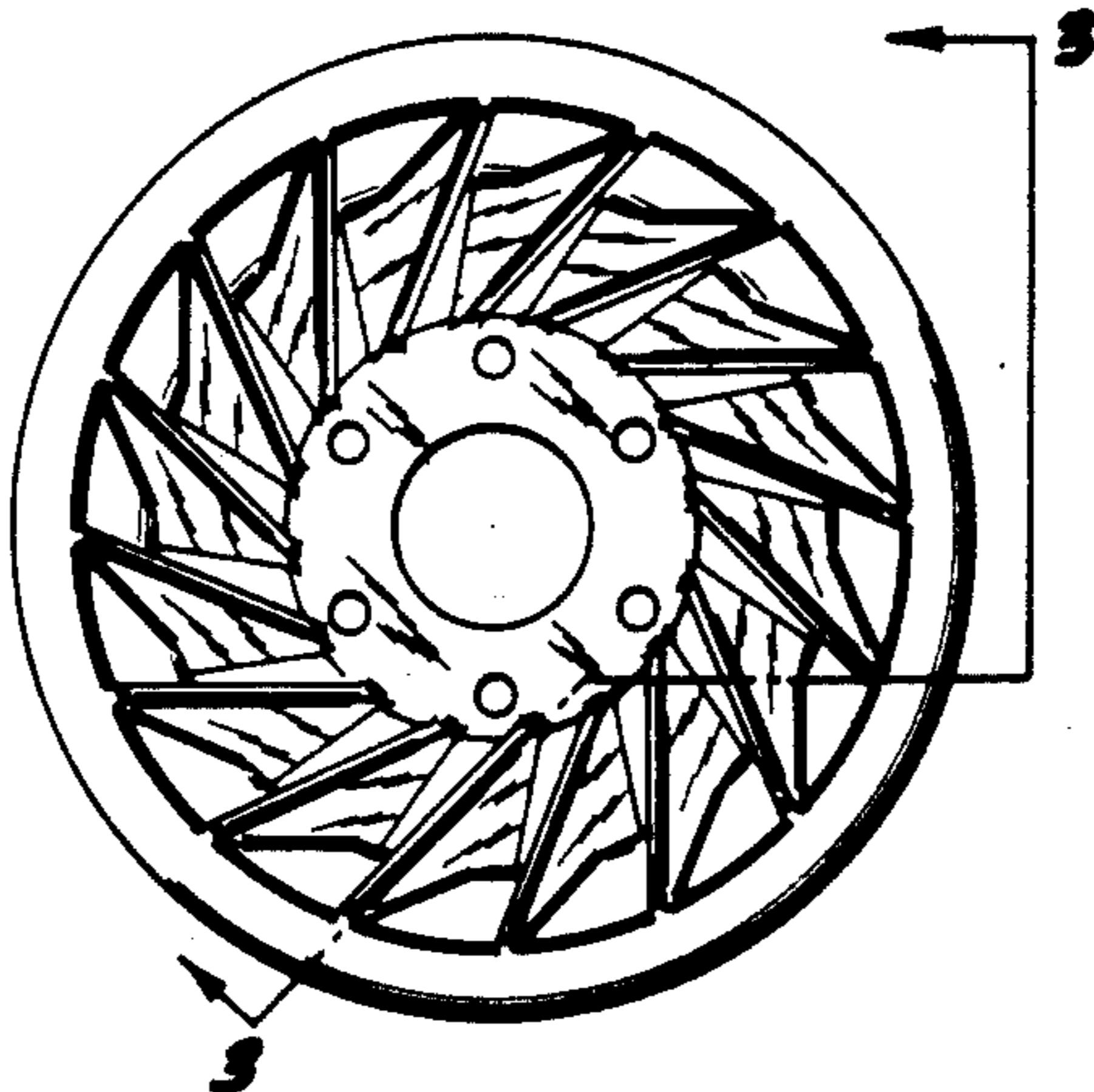

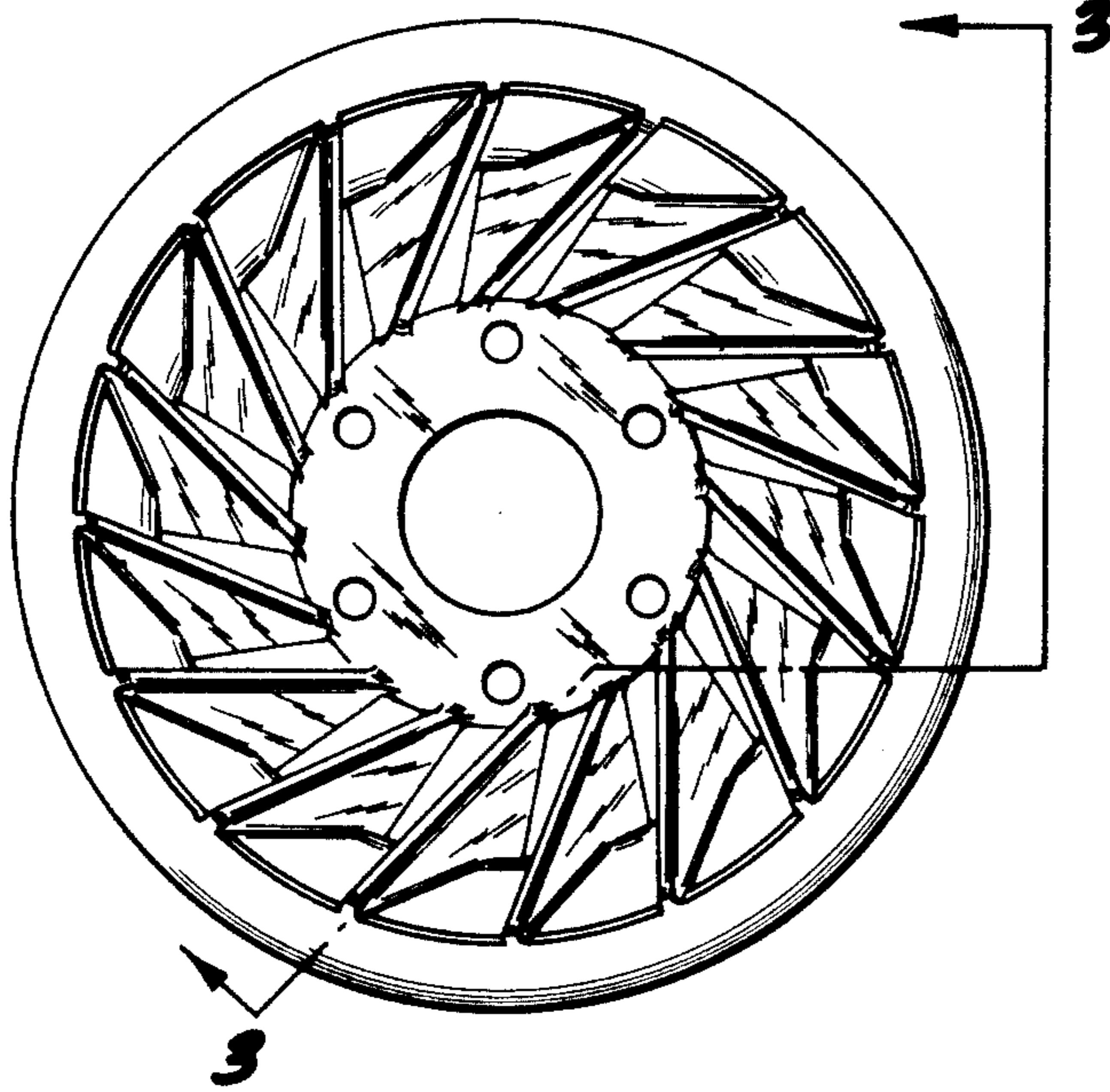
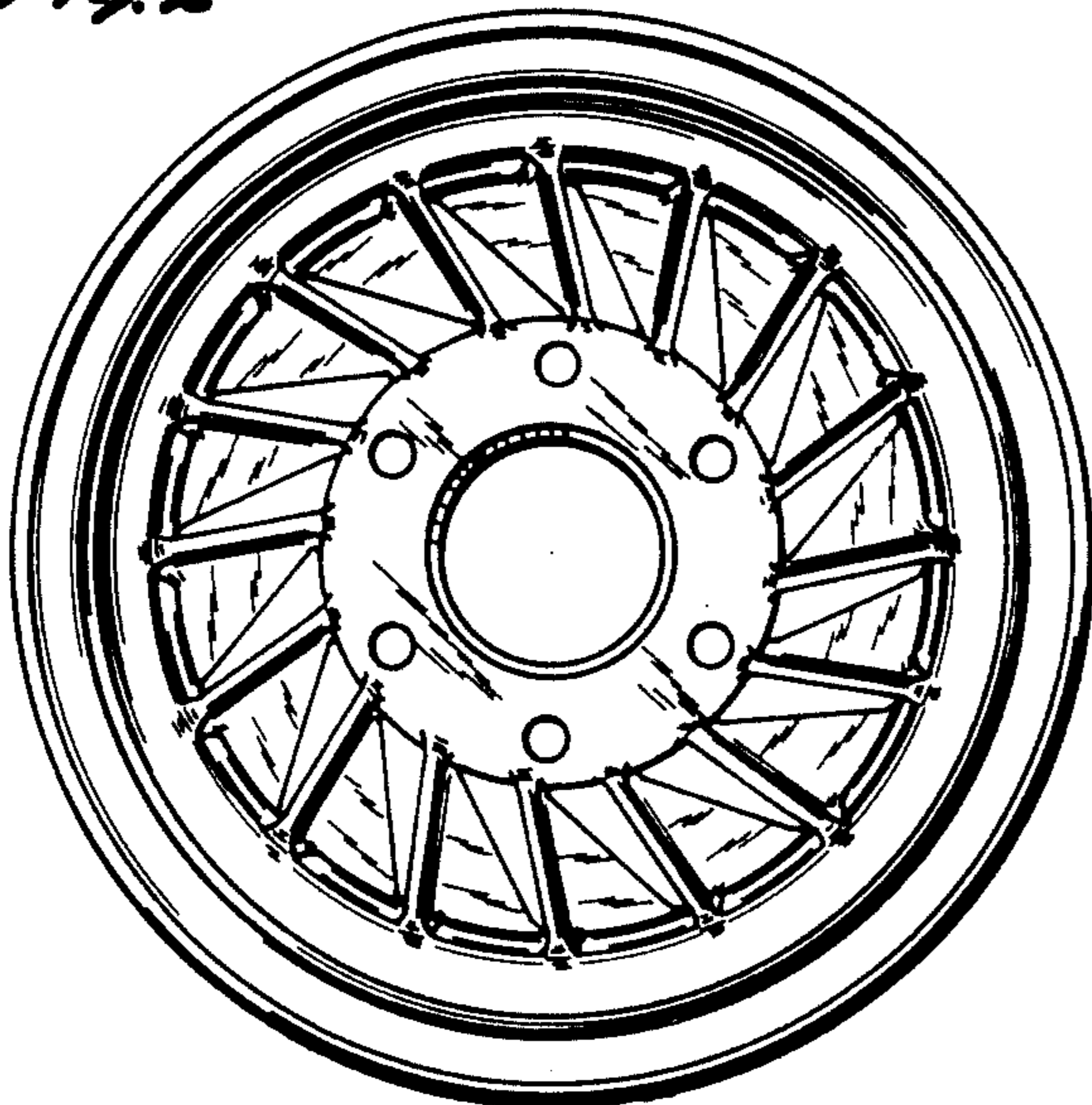

*Fig. 1*



*Fig. 3*

*Fig. 2*



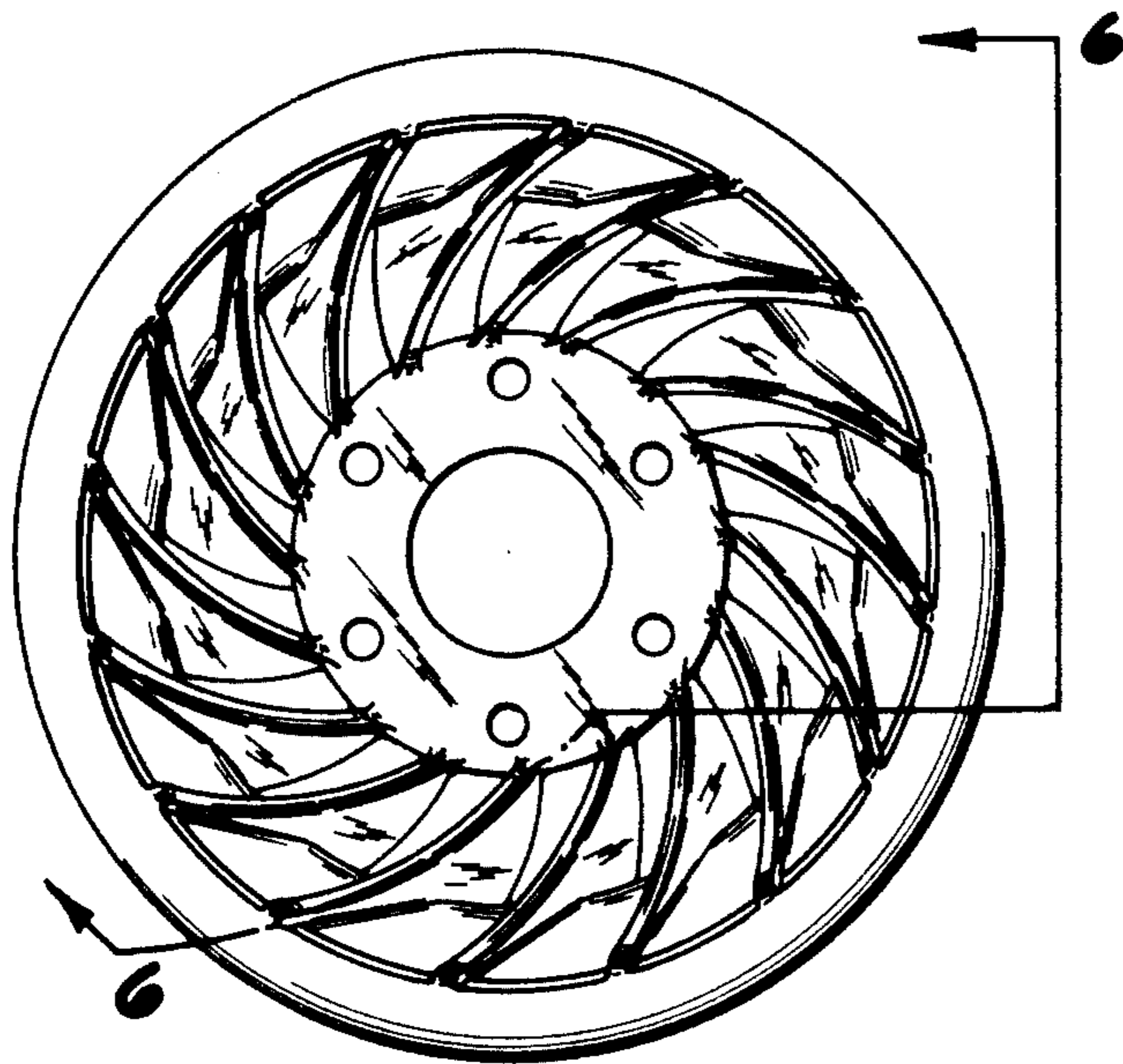

*Fig. 4*



*Fig. 6*

*Fig. 5*

