

[54] TRUCK CAB CADDY

[76] Inventor: Andre J. Olivan, 3970 Bayview Cir., Concord, Calif. 94520

[**] Term: 14 Years

[21] Appl. No.: 681,152

[22] Filed: Apr. 28, 1976

[51] Int. Cl. D12-16

[52] U.S. Cl. D12/155

[58] Field of Search D12/155, 190; D6/130, D6/131, 137, 114, 140, 186, 188, 189, 181; 312/245; 220/1 V; 211/88, 71, 72, 126, 55; 224/29 R, 29 M, 42.39, 42.42 R, 42.42 A, 42.46 R; 296/37.1, 37.6, 37.8, 37.12, 37.13, 37.16, 37.9

[56] References Cited

U.S. PATENT DOCUMENTS

D. 202,983	11/1965	Allen	D12/155
D. 237,836	11/1975	Anderson	D6/130
1,530,793	3/1925	Stephens	312/245
2,980,281	4/1961	Stewart	312/245

FOREIGN PATENT DOCUMENTS

913,610	6/1946	France	211/88
---------	--------	--------------	--------

OTHER PUBLICATIONS

Office Products, 12/75, p. 113, Sign Plate on File Drawer, center of page.

Office Products, 9/75, p. 172, Sign Plate on File Drawer, center right side of page.

J. C. Whitney Catalog, No. 345, ©1975, p. 21, Door Storage Rack, Style A, center right side of page.

Primary Examiner—Wallace R. Burke

Assistant Examiner—James M. Gandy

Attorney, Agent, or Firm—Stephen M. Westbrook

[57] CLAIM

The ornamental design for a truck cab caddy, as shown and described.

DESCRIPTION

FIG. 1 is a perspective view of a truck cab caddy embodying my design.

FIG. 2 is a front elevational view therefor.

FIG. 3 is a side elevational view therefor.

FIG. 4 is a top plan view thereof.

FIG. 5 is a bottom plan view thereof.

FIG. 6 is a rear elevational view therefor.

The side of the caddy opposite that shown in FIG. 3 is a mirror image therefor.

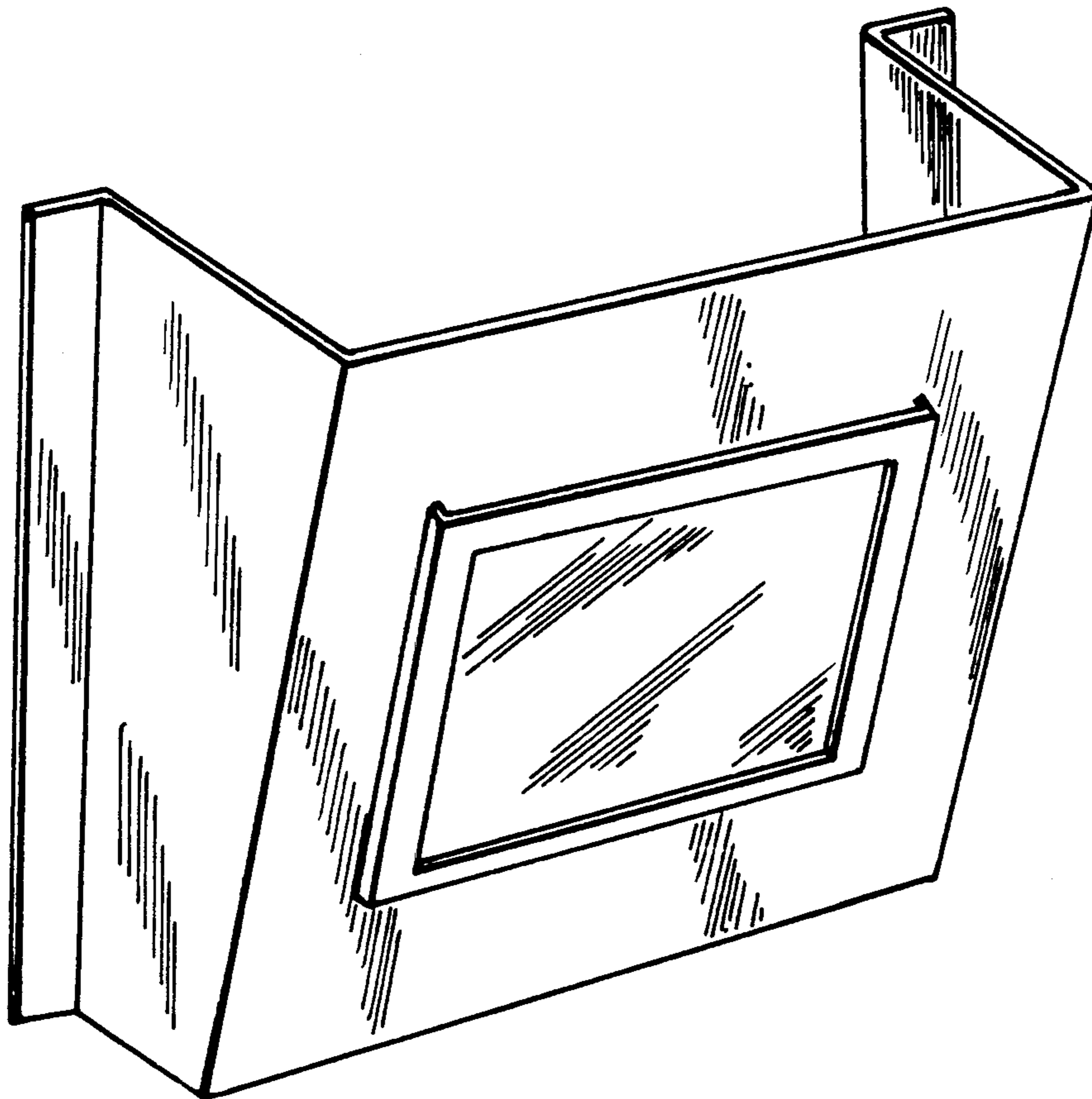

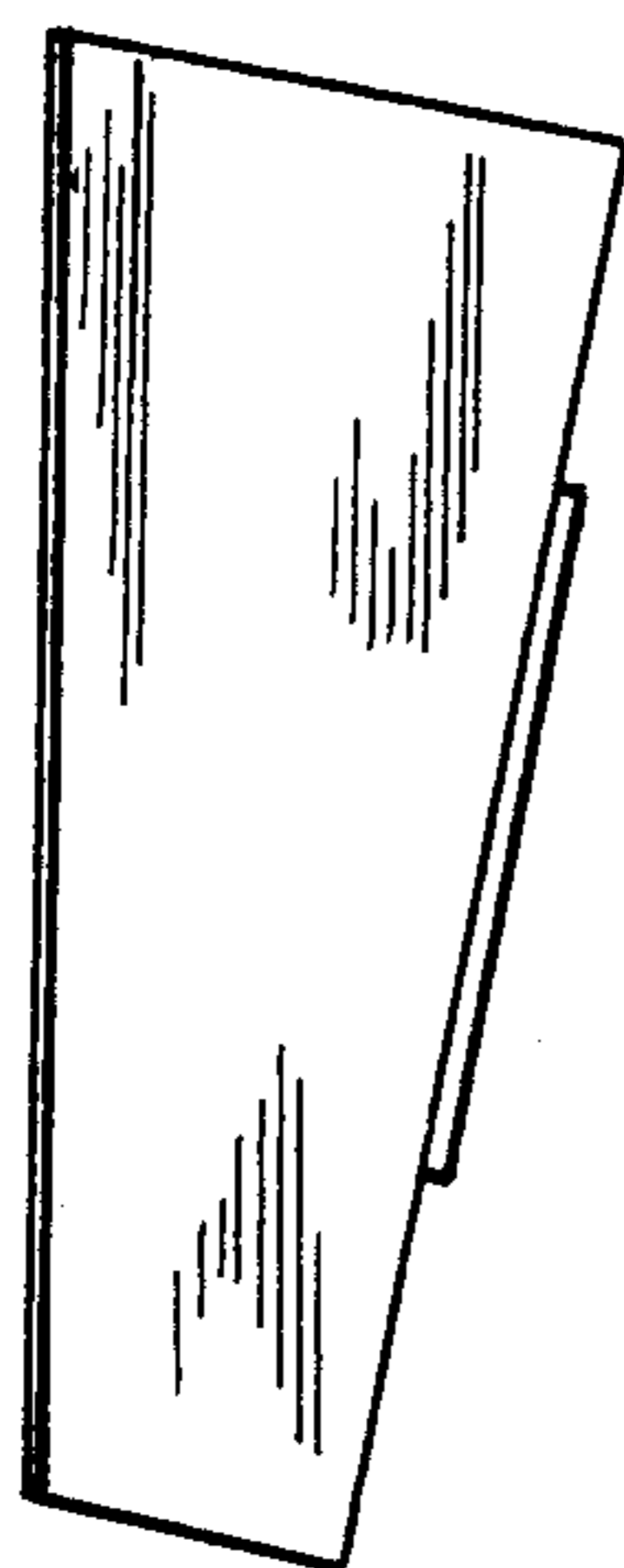

FIG _ 3

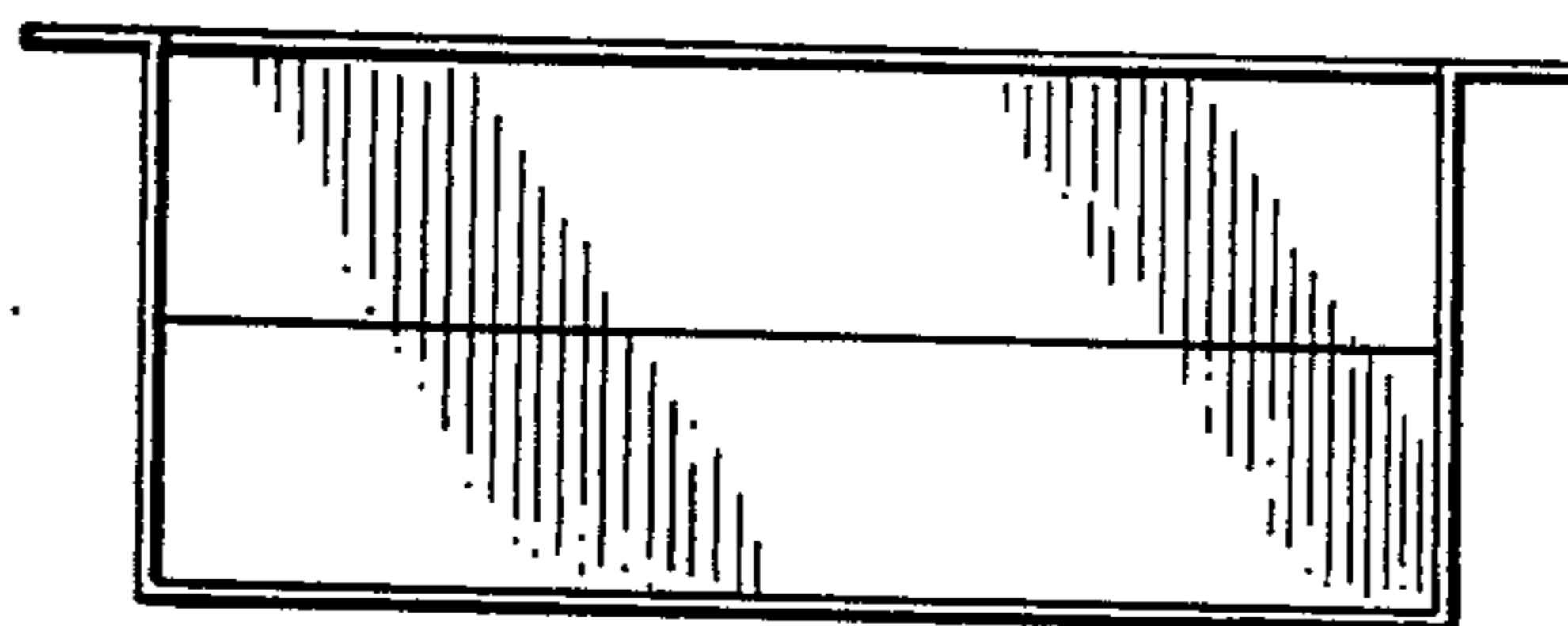

FIG _ 4

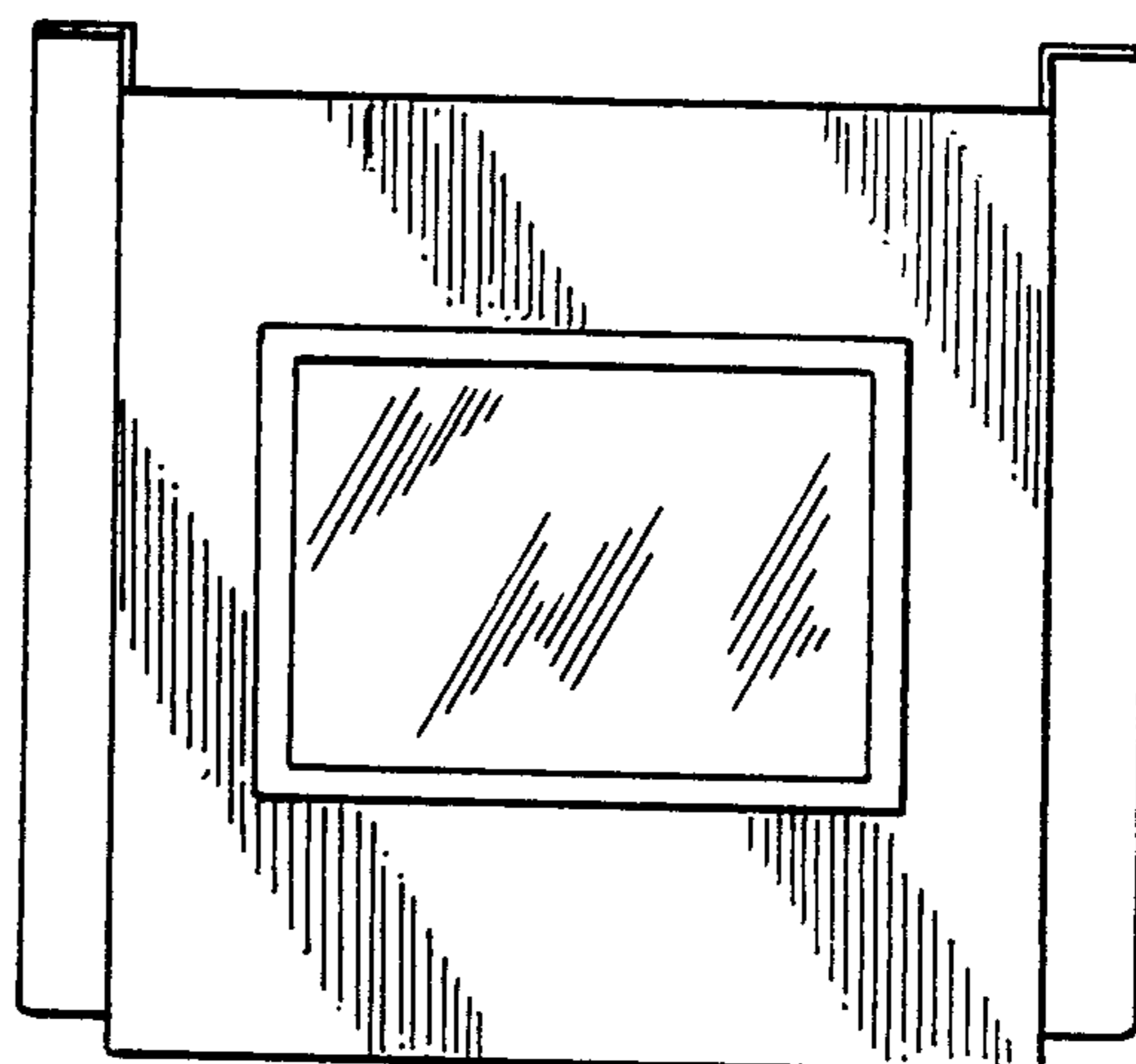

FIG _ 2

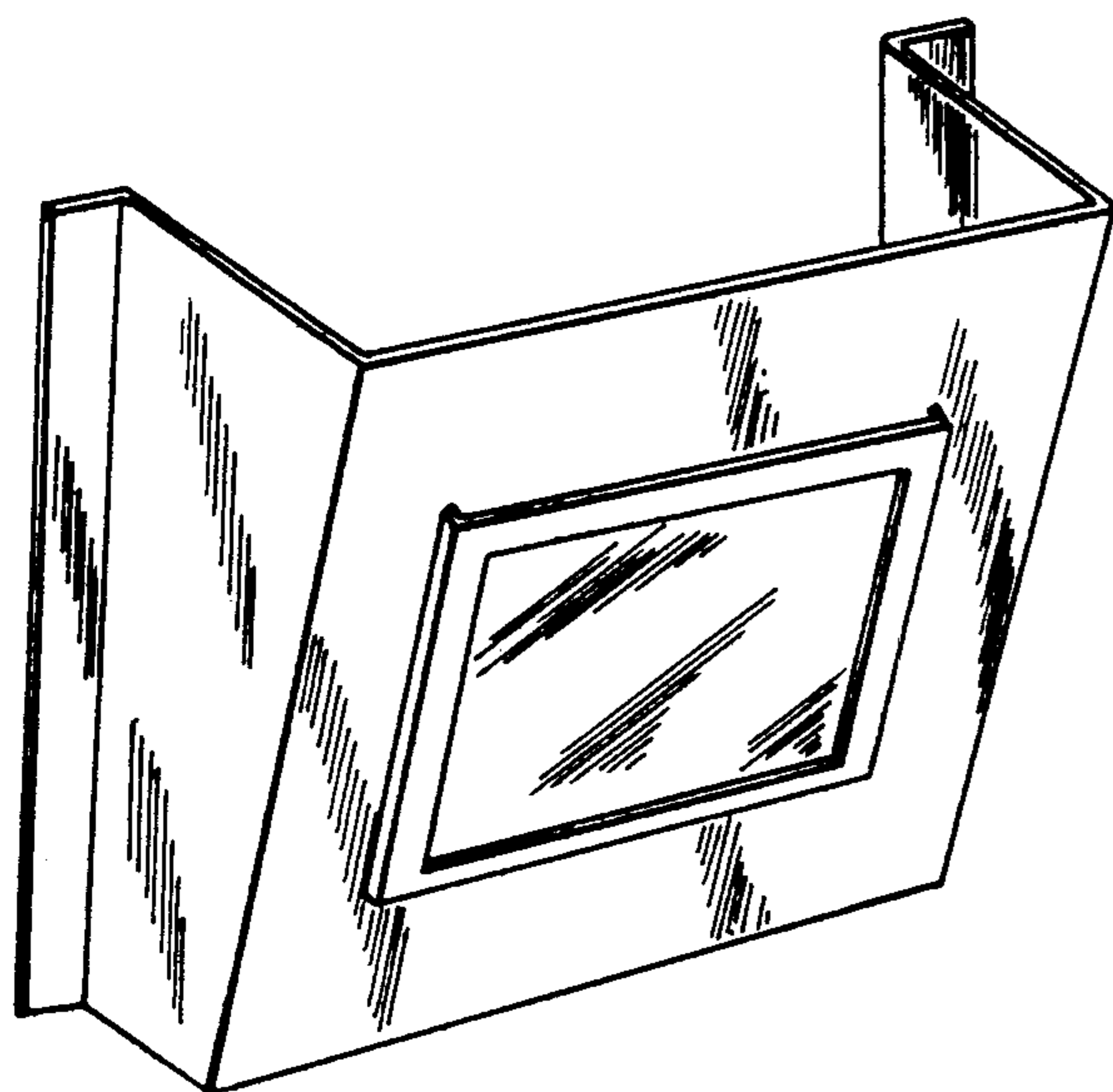

FIG _ 1

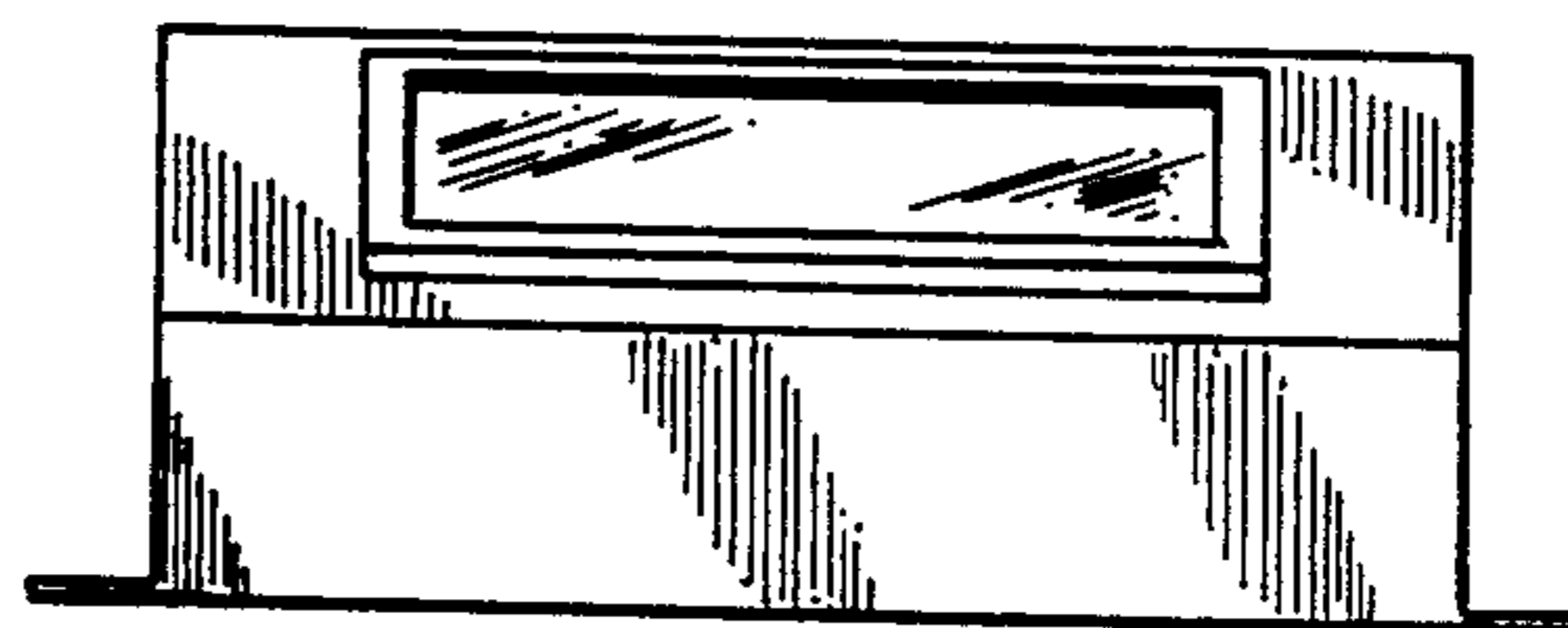

FIG _ 5

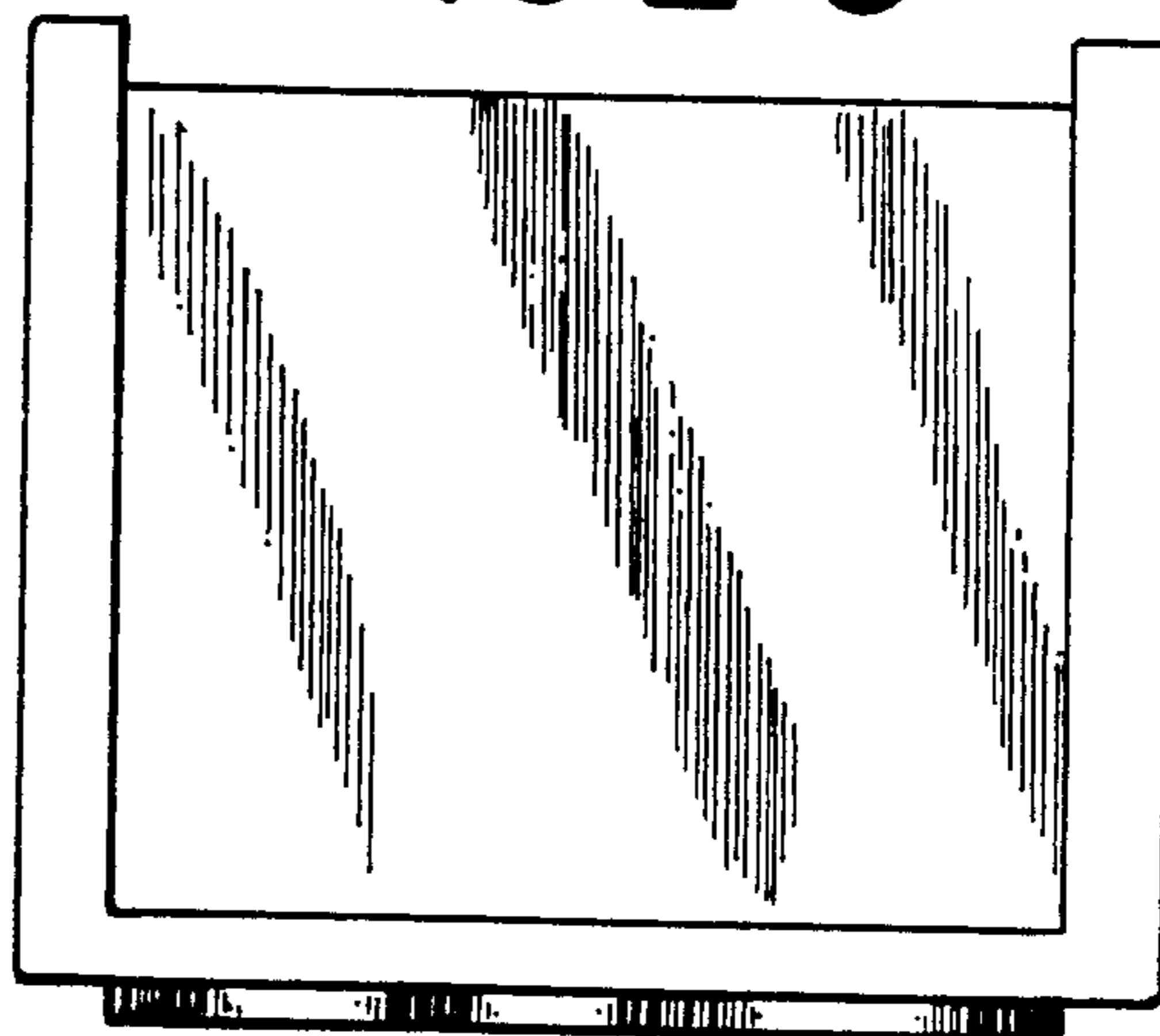

FIG _ 6