

[54] STRIPPER PAD

[75] Inventor: Eugene Behun, Rochester, N.Y.

[73] Assignee: Xerox Corporation, Stamford, Conn.

[\*\*] Term: 14 Years

[21] Appl. No.: 750,096

[22] Filed: Dec. 13, 1976

[51] Int. Cl. .... D16-03

[52] U.S. Cl. .... D16/32

[58] Field of Search ..... D16/27, 32; 271/DIG. 2, 271/80, 174; 432/59, 60; 34/120; 118/245; 355/3 R; 100/174

[56] References Cited

U.S. PATENT DOCUMENTS

- 3,912,256 10/1975 Nagahara ..... 271/DIG. 2 X
- 3,938,950 2/1976 Weiler et al. .... 271/DIG. 2 X

- 3,955,889 5/1976 Ishiguro et al. .... 271/DIG. 2 X
- 3,981,085 9/1976 Franko ..... 271/DIG. 2 X
- 4,028,050 6/1977 Bar-On ..... 271/DIG. 2 X
- 4,035,140 7/1977 Tsuda et al. .... 432/60

Primary Examiner—Wallace R. Burke  
Assistant Examiner—Catherine Kemper  
Attorney, Agent, or Firm—James J. Ralabate

[57] CLAIM

The ornamental design for a stripper pad, as shown.

DESCRIPTION

FIG. 1 is a left side perspective view of a stripper pad showing my new design;  
FIG. 2 is a left side elevational view thereof;  
FIG. 3 is a right side elevational view thereof;  
FIG. 4 is a top plan view thereof;  
FIG. 5 is a bottom plan view thereof;  
FIG. 6 is a front elevational view thereof; and  
FIG. 7 is a rear elevational view thereof.

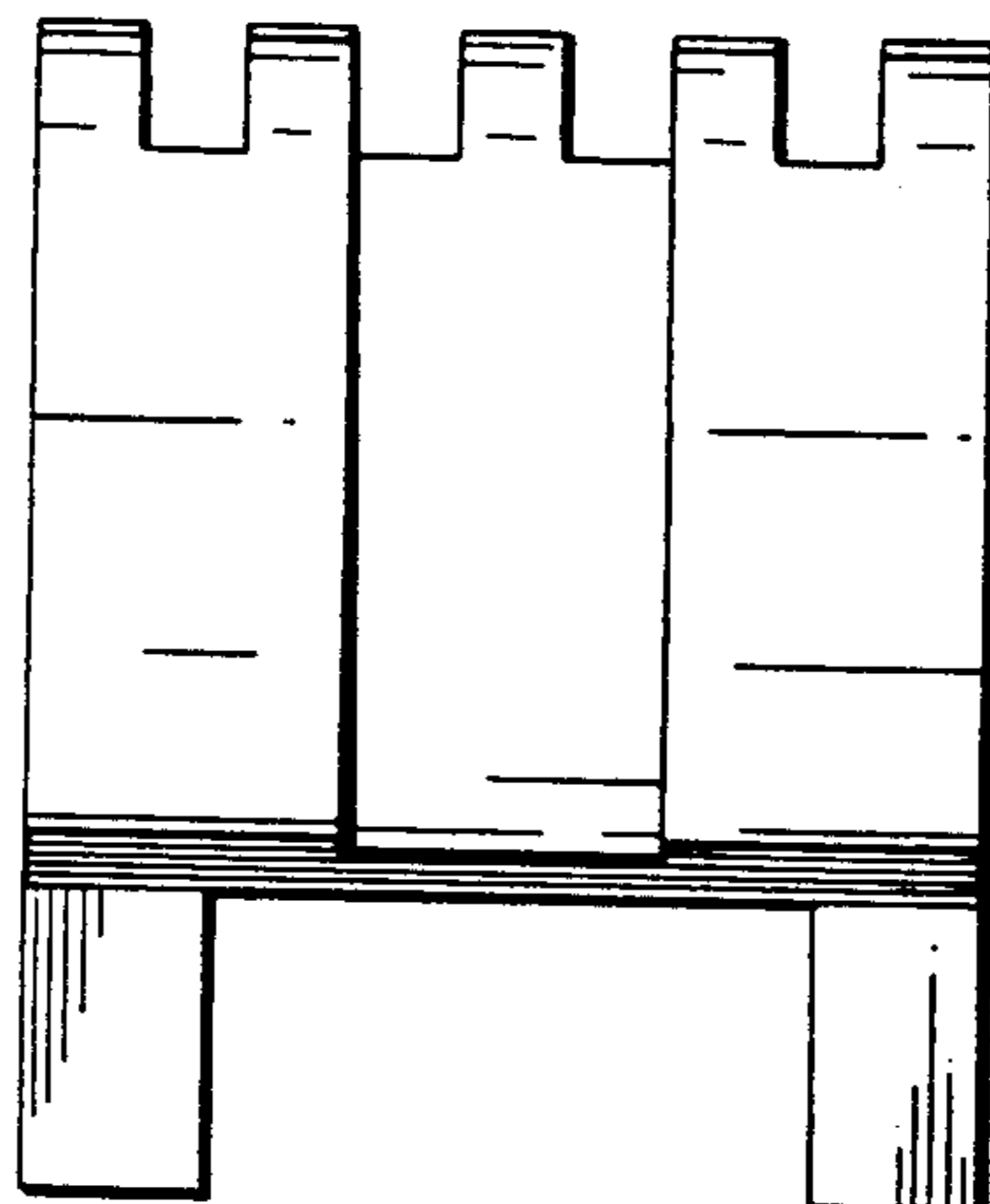
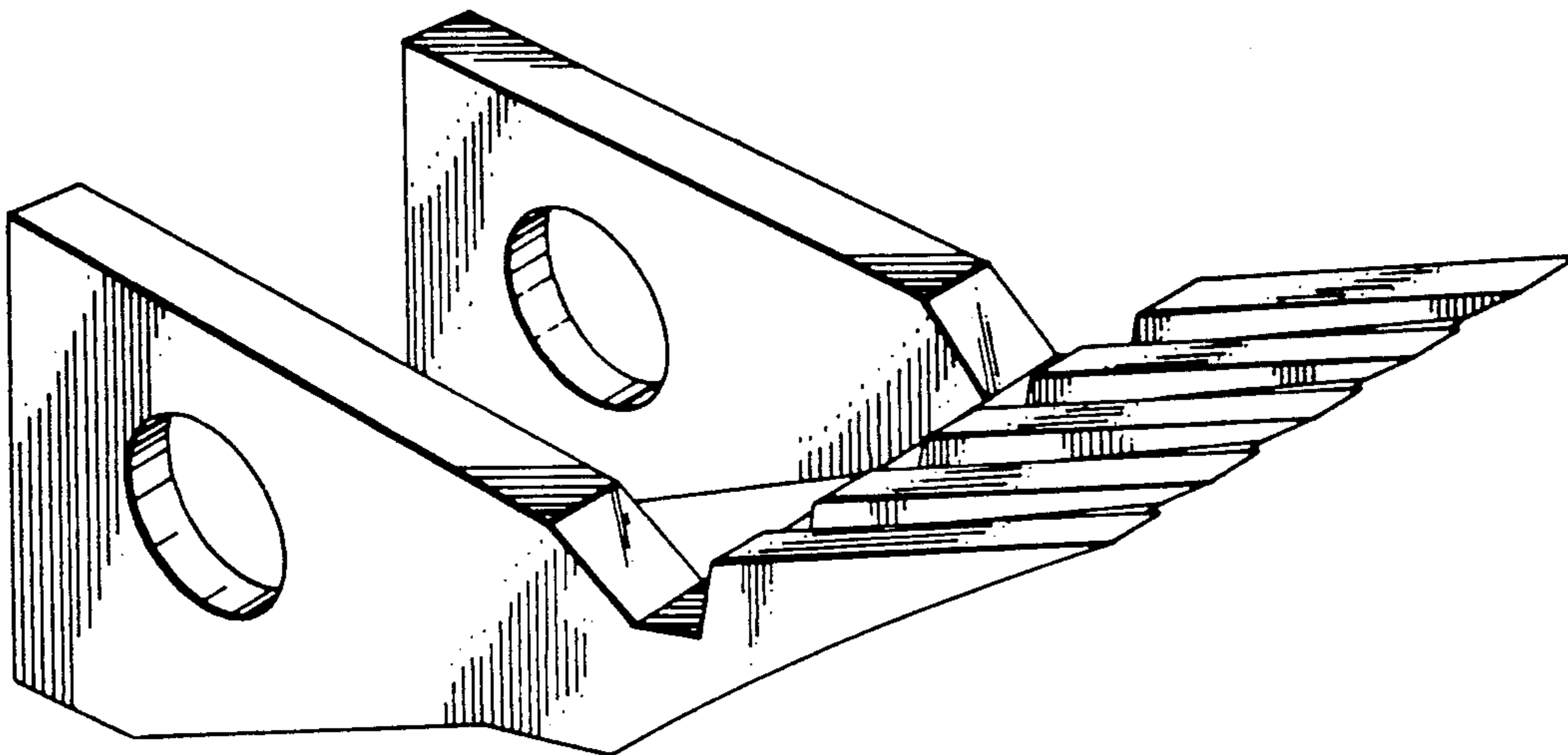

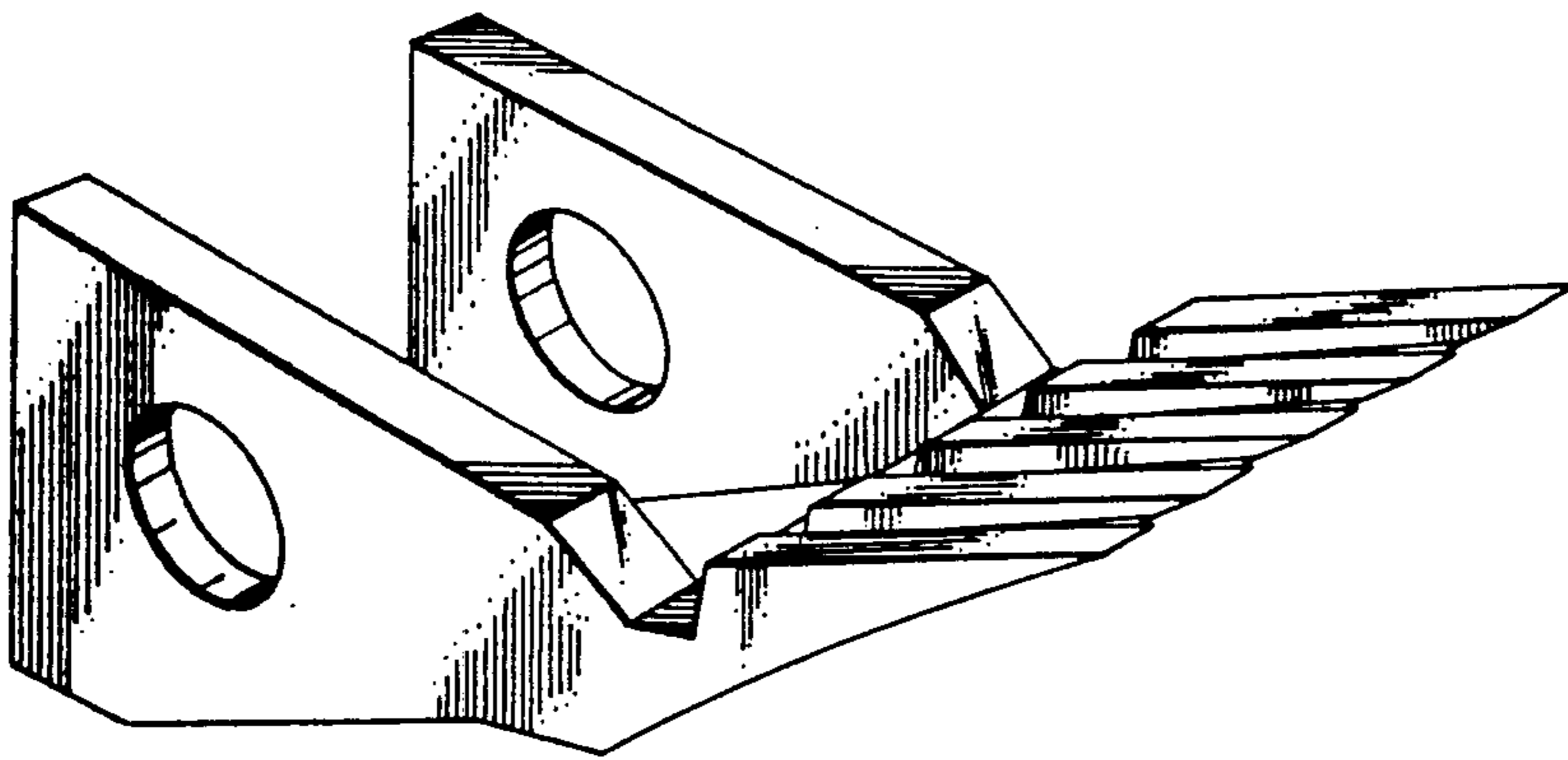

FIG. 1

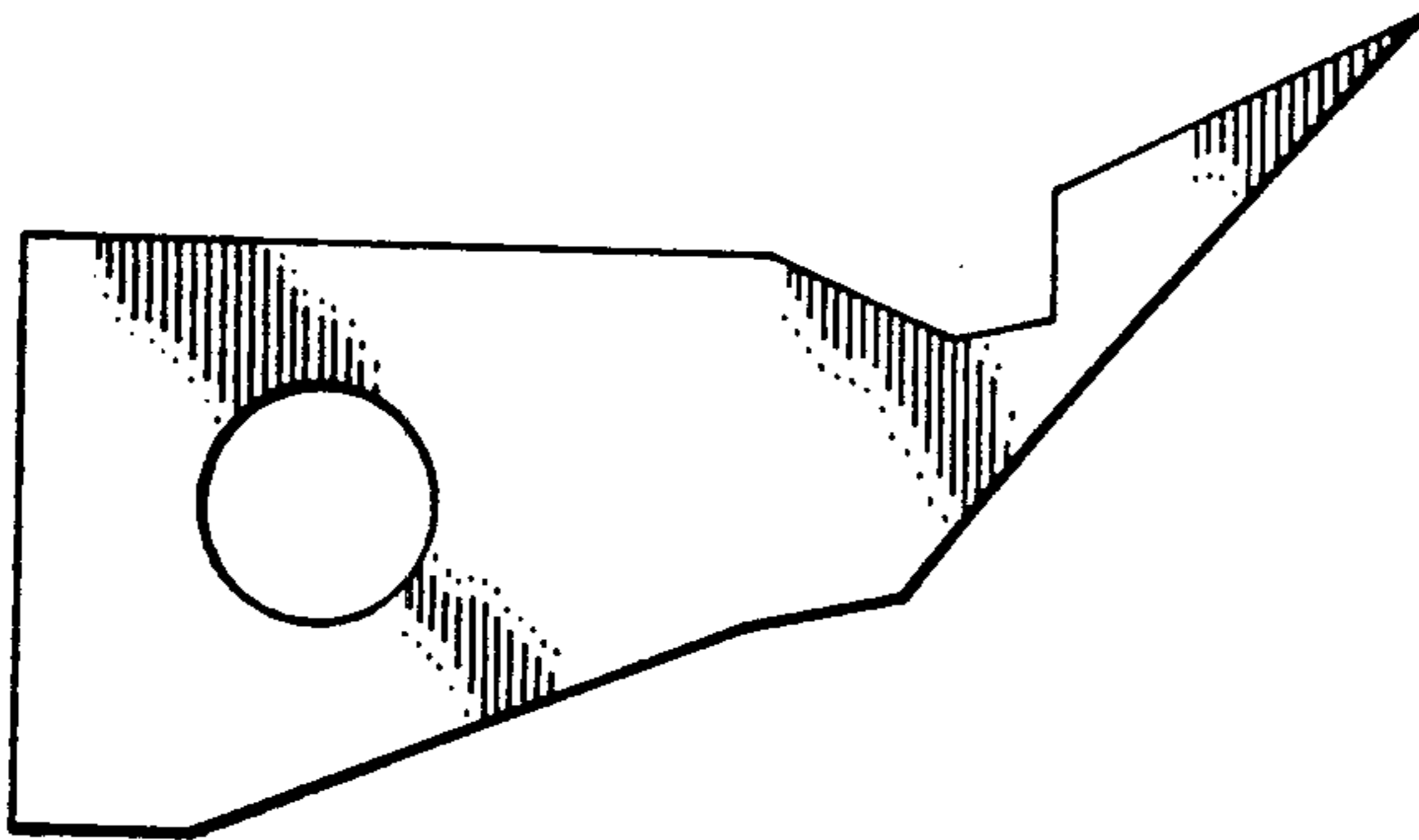

FIG. 2

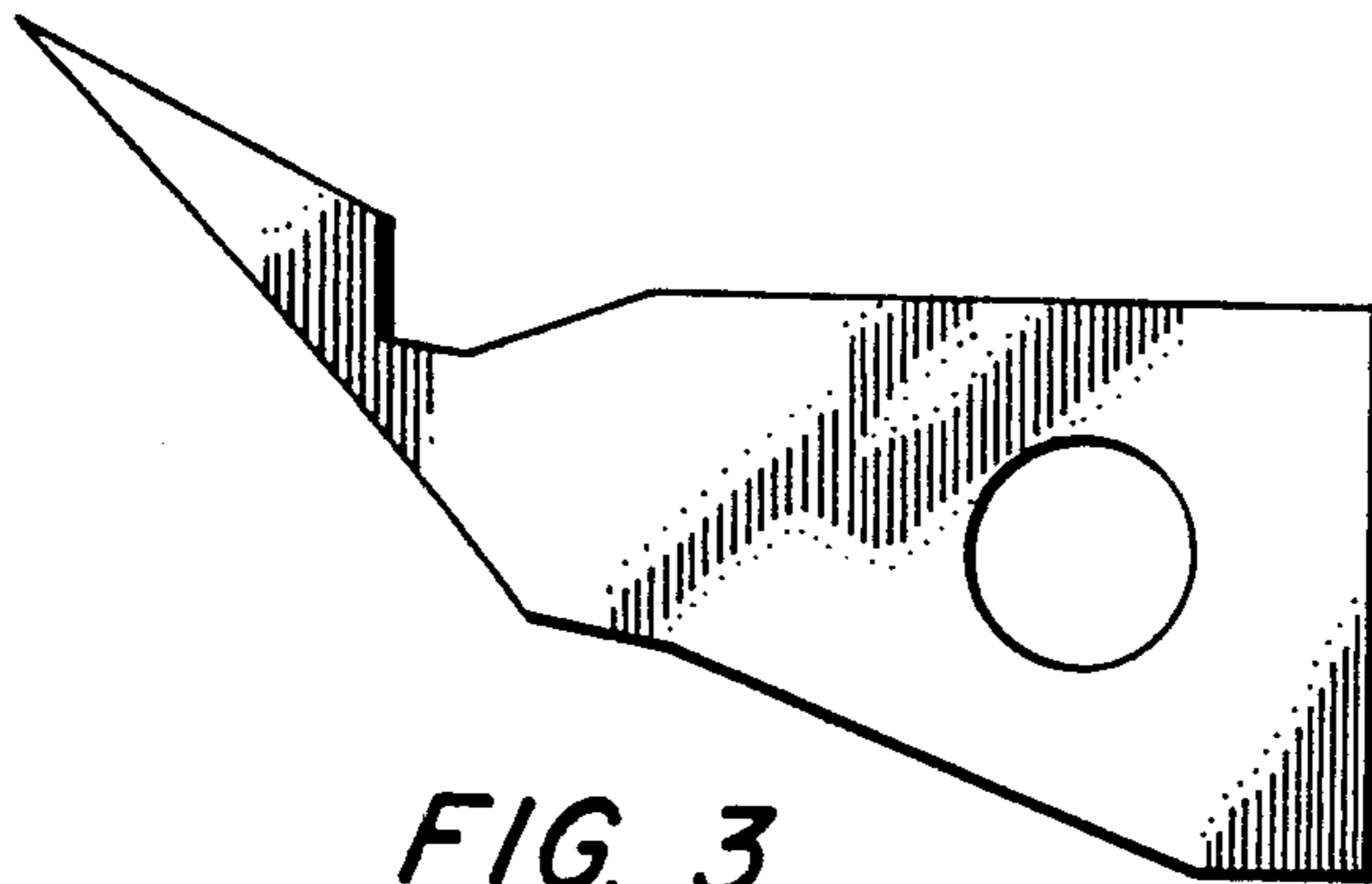

FIG. 3

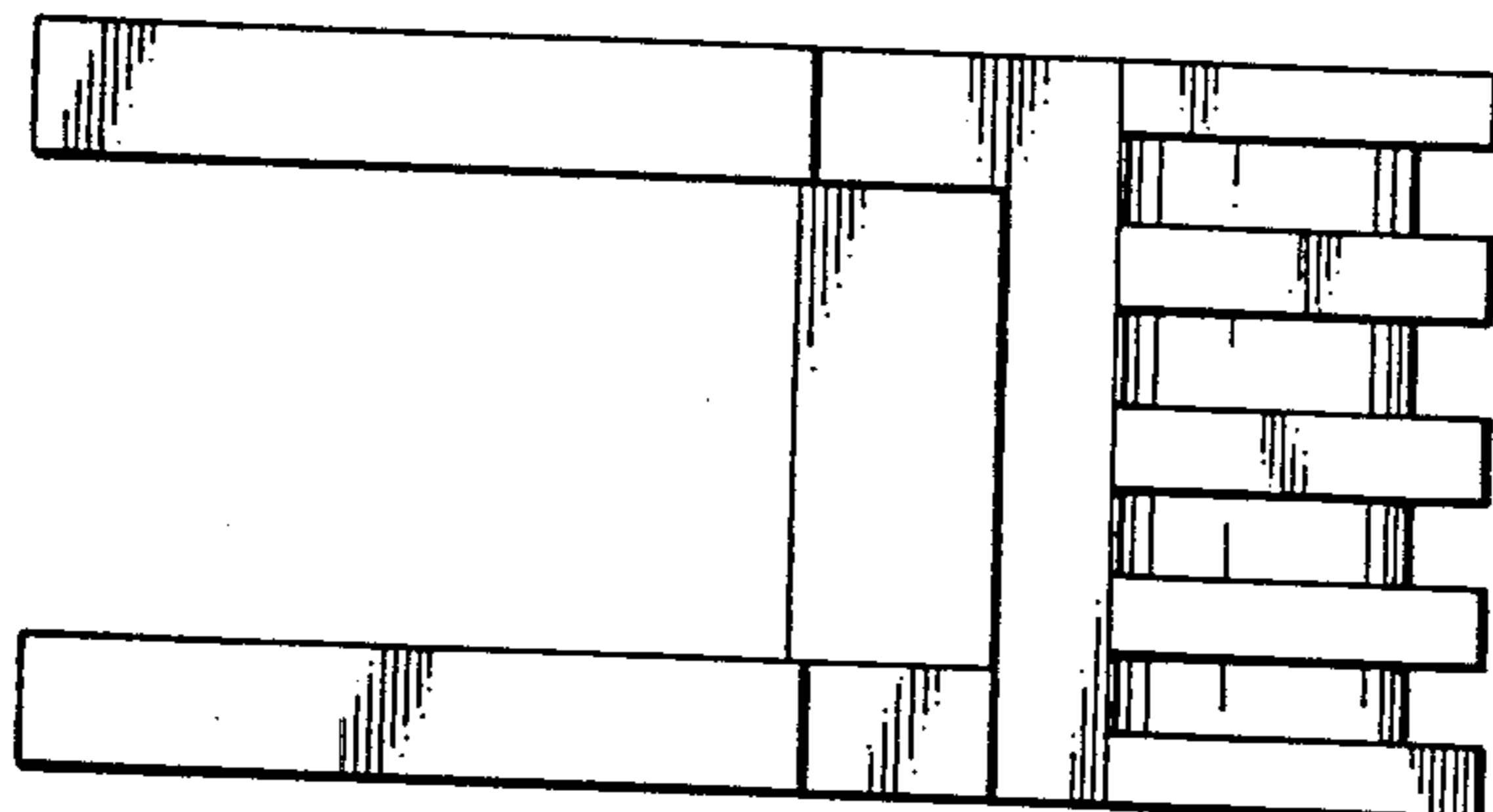

FIG. 4

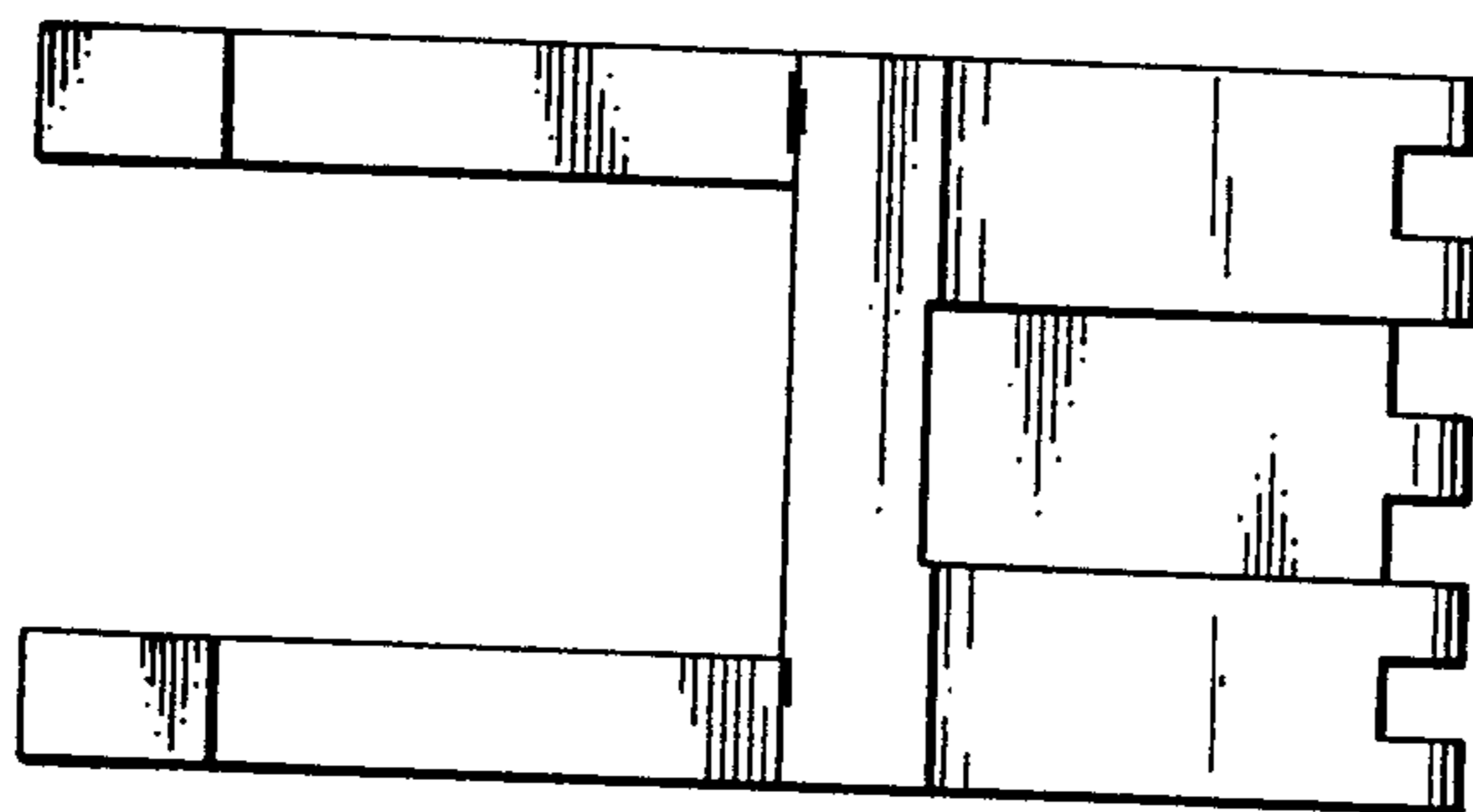

FIG. 5

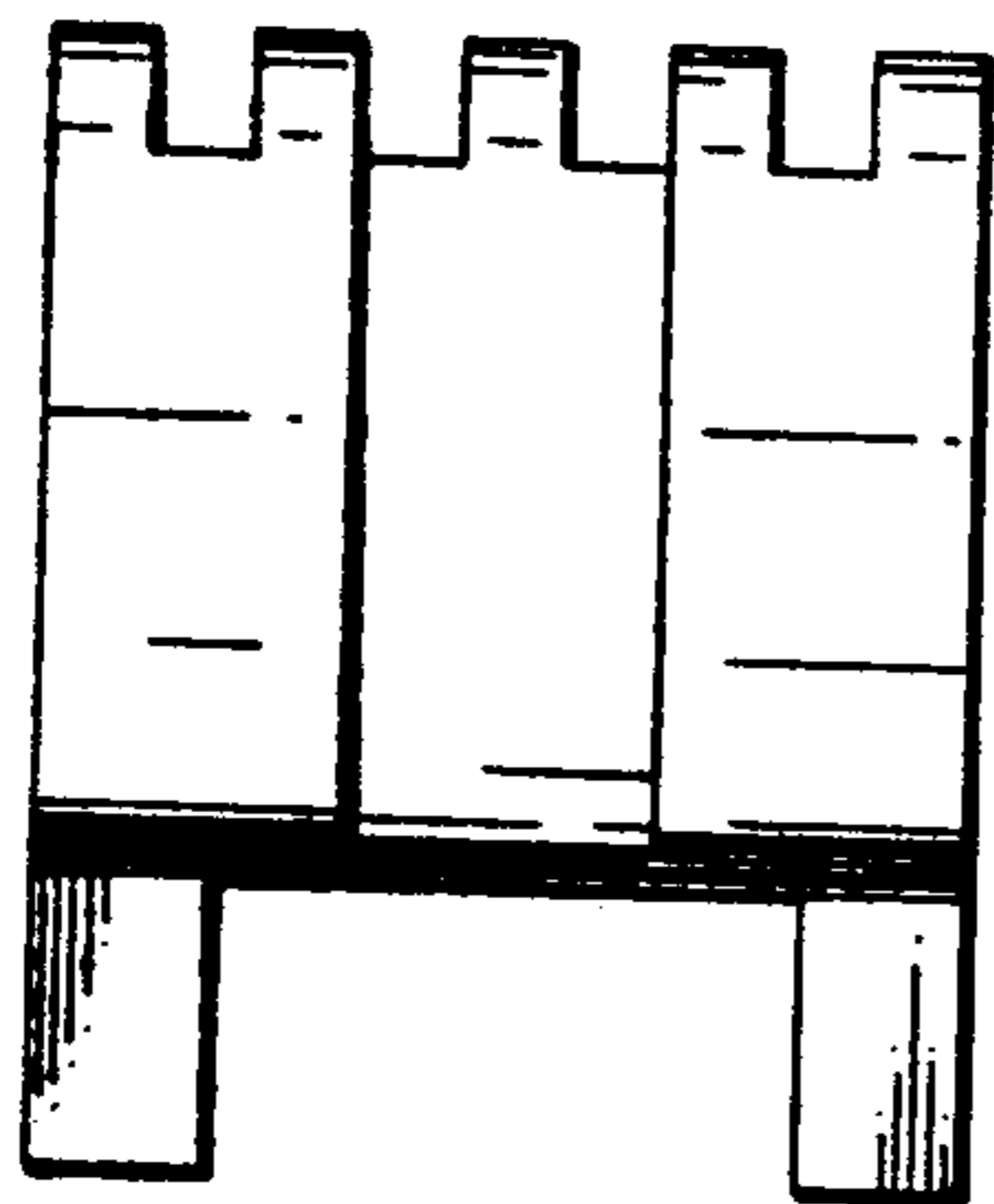

FIG. 6

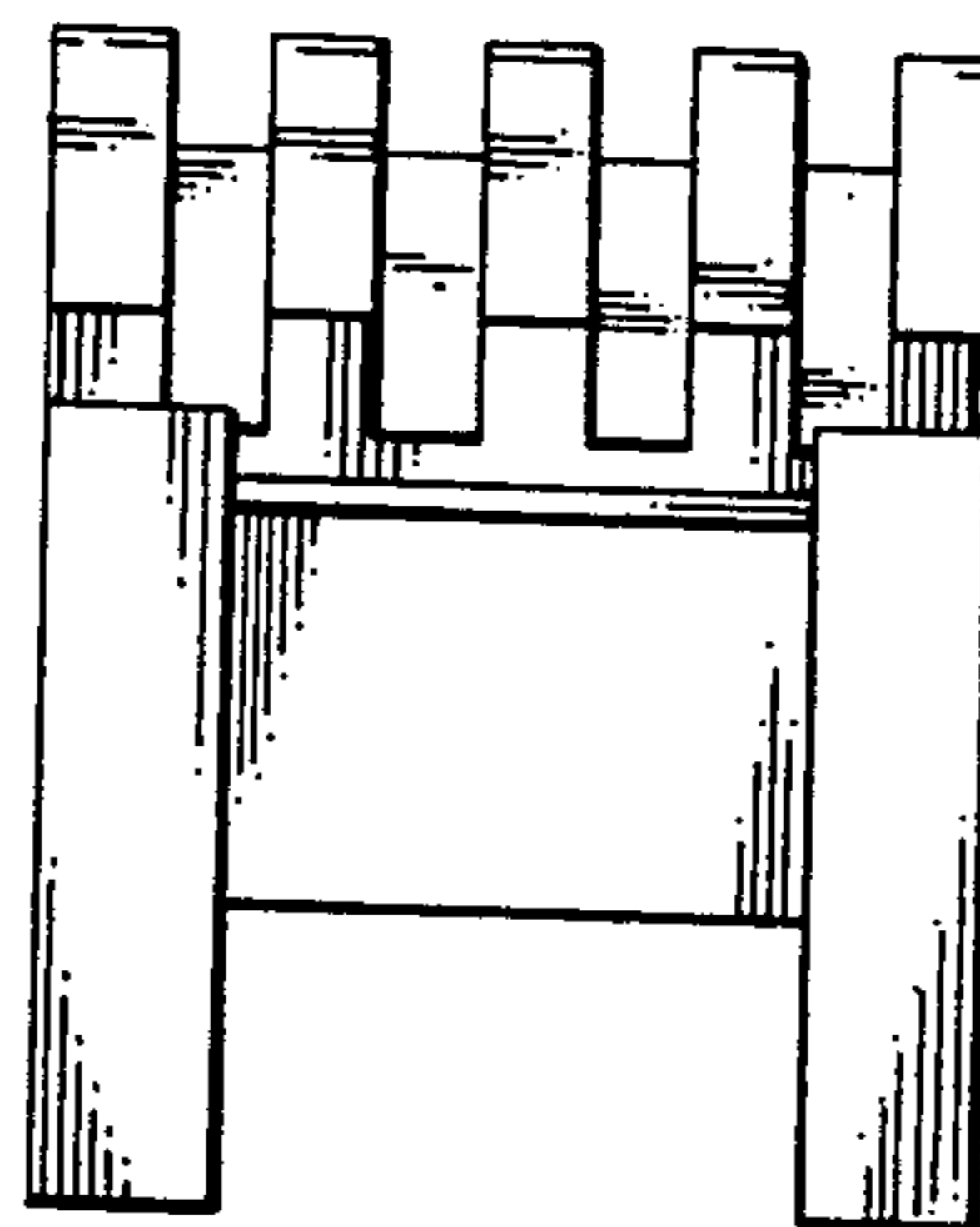

FIG. 7